

**2001
Pioneer 1200
Owner's Manual**

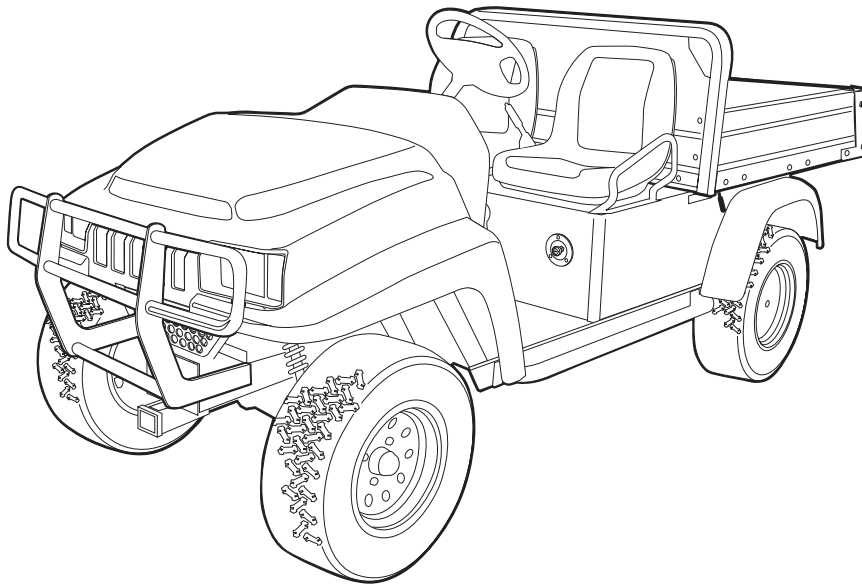

**Gasoline Utility Vehicle
Non-Standard**

Manual Number 102189817
Edition Code 0800B0109A

EMISSION CONTROL INFORMATION

Fuel Information

THIS VEHICLE IS CERTIFIED TO OPERATE ON UNLEADED REGULAR GRADE GASOLINE ONLY. A minimum of 87 octane of the anti-knock index is recommended. The anti-knock index is posted on service station pumps in the U.S.A.

Emission Control Information

To protect the environment in which we all live, Club Car has incorporated crankcase emission (1) and exhaust emission (2) control systems (EM) in compliance with applicable regulations of the U.S. Environmental Protection Agency and California Air Resources Board.

1. Crankcase Emission Control System

A sealed-type crankcase emission control system is used to eliminate blow-by gases. The blow-by gases are led to the breather chamber through the crankcase. Then, it is led to the air cleaner.

Oil is separated from the gases while passing through the inside of the breather chamber from the crankcase, and then returned back to the bottom of the crankcase.

2. Exhaust Emission Control System

The exhaust emission control system applied to this engine consists of a carburetor and an ignition system having optimum ignition timing characteristics.

The carburetors have been calibrated to provide lean air/fuel mixture characteristics and optimum fuel economy with a suitable air cleaner and exhaust system.

Maintenance and Warranty

Proper maintenance is necessary to ensure that your engine will continue to have low emission levels. Those items identified by the Periodic Maintenance Chart are necessary to ensure compliance with the applicable standards.

The Club Car Limited Emission Control System Warranty requires that you return your engine to an authorized Club Car Dealer for remedy under warranty. Please read the warranty carefully, and keep it valid by complying with the owner's obligations it contains.

Tampering with Emission Control System Prohibited

California State law prohibits the following

acts or the causing thereof: (1) the removal or rendering inoperative by any person other than for purposes of maintenance, repair, or replacement, of any device or element of design incorporated into any new engine for the purposes of emission control prior to its sale or delivery to the ultimate purchaser or while it is in use, or (2) the use of the engine after such device or element of design has been removed or rendered inoperative by any person.

Among those acts presumed to constitute tampering are the acts listed below:

Do not tamper with the original emission related parts:

- Carburetor and internal parts
- Spark plugs
- Magneto or electronic ignition system
- Fuel filter element
- Air cleaner element
- Crankcase
- Cylinder head
- Breather chamber and internal parts
- Intake pipe and tube

FUEL AND OIL RECOMMENDATIONS

Fuel

Use only clean, fresh, unleaded regular grade gasoline.

Octane Rating

The octane rating of a gasoline is a measure of its resistance to "knocking". Use of a minimum of 87 octane of the anti-knock index is recommended. The anti-knock index is posted on service station pumps in the U.S.A.

NOTE

- If "knocking or pinging" occurs, use a different brand of gasoline or higher octane rating.

CAUTION

- Do not mix oil with gasoline.

Oxygenated Fuel

If you use oxygenated fuel (either ethanol or MTBE added to gasoline), be sure it is unleaded and meets the minimum octane rating requirement.

The following are the EPA approved percentages of fuel oxygenates.

ETHANOL: (Ethyl or Grain Alcohol) You may use gasoline containing up to 10% ethanol by volume.

MTBE: (Methyl Tertiary Butyl Ether) You may use gasoline containing up to 15% MTBE by volume.

METHANOL: (Methanol or Wood Alcohol) 5% by volume.

You may use gasoline containing up to 5% methanol by volume, as long as it also contains cosolvents and corrosion inhibitors to protect the fuel system. Gasoline containing more than 5% methanol by volume may cause starting and/or performance problems. It may also damage metal, rubber, and plastic parts of your fuel system.

WARNING

- Gasoline is extremely flammable and can be explosive under certain conditions. Turn the engine switch OFF. Do not smoke. Make sure the area is well ventilated and free from any source of flame or sparks; this includes any appliance with a pilot light. Never fill the tank so the fuel level rises into the filler neck. If the tank is overfilled, heat may cause the fuel to expand and overflow through the vent in the fuel tank.

Engine Oil

The following engine oils are recommended. API Service Classification: SC, SD, SE, SF, SG, or SH.

WARNING

- After refueling, make sure the tank cap is closed securely.
- If gasoline is spilled on the fuel tank wipe it off immediately.

Oil Viscosity

Choose the viscosity according to the temperature as follows:

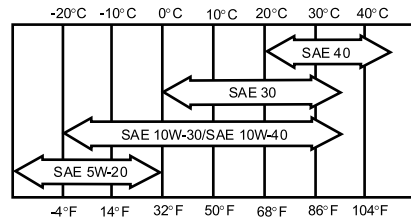

NOTE

- Using multi-grade oils (5W-20, 10W-30, and 10W-40) will increase oil consumption. Check oil level more frequently when using them.

WARNING

- THE ENGINE EXHAUST FROM THIS PRODUCT CONTAINS CHEMICALS KNOWN TO THE STATE OF CALIFORNIA TO CAUSE CANCER, BIRTH DEFECTS, OR OTHER REPRODUCTIVE HARM.

NOTICE

The Pioneer™ Vehicle Limited Warranty appears on the last pages of this manual. No other warranties, express or implied, are contained herein. Please complete and return the warranty registration card included in this manual.

Club Car is not liable for errors in this manual or for incidental or consequential damages that result from the use of the material in this manual.

This manual contains proprietary information that is protected by copyright. All rights are reserved. No part of this manual may be photocopied, reproduced, or translated to another language without the written consent of Club Car, Inc.

The information contained in this document is subject to change without notice.

Club Car reserves the right to make design changes to vehicles without obligation to make these changes on units previously sold.

These vehicles do not conform to Federal Motor Vehicle Safety Standards for automobiles or to FMVSS 500 for low-speed vehicles, and are not equipped for operation on public streets, roads, or highways.



P.O. Box 204658
Augusta, Georgia 30917-4658 USA
Telephone: 1-800-ClubCar (258-2227)
www.clubcar.com

©2000 Club Car, Inc.

Club Car is a registered trademark
of Club Car, Inc.

This manual effective July 10, 2000

FOREWORD

Thank you for choosing Club Car. You have chosen the finest utility vehicle on the market; the vehicle most widely recognized as the industry leader in vehicle efficiency and long-lasting value. Please protect your investment and ensure that your Club Car vehicle(s) provides years of reliable, superior performance by reading and following the maintenance instructions in this manual.

Your comfort and safety are important to us, so we urge you to read and follow the step-by-step operating instructions and safety procedures in this manual. These instructions must be followed in order to avoid the risk of severe personal injury. If you rent or loan your vehicle to others, we recommend that you ask them to read this manual before they operate the vehicle.

Club Car products are backed by a customer support system designed to offer you fast, courteous service. In the event that your Club Car vehicle needs repairs or service, we recommend that your local authorized Club Car representative perform them. For the name and address of the Club Car representative nearest you, logon to our web site at www.clubcar.com or call 1-800-ClubCar (258-2227). If you would prefer to write to us, direct your letter to: Club Car, Attention: Marketing Services, P.O. Box 204658, Augusta, Georgia 30917-4658 USA. Your local authorized Club Car representative can also provide technical advice, parts, and service manuals.

We hope you will consider this owner's manual a permanent part of your Club Car vehicle. If you sell the vehicle, please include the manual so that the next owner will have the important operating, safety, and maintenance information it contains.

Practice Safety



Safety signs like you see above may at first seem shocking, but their impact is mild compared with the reality of severe personal injury.

Your safety and satisfaction are of the utmost importance to Club Car. That is why before operating the vehicle, we urge you to review the information in this manual. Understand and become familiar with the DANGER, WARNING and CAUTION statements and procedures it contains, along with the safety decals that are affixed to your vehicle.

Take time to understand the language of safety. It is a language that can save your life.

TABLE OF CONTENTS

Safety Details	7
Vehicle Feature Identification	8
General Warnings	10
General Information	11
Model Identification	11
Pre-Operation Checklist	11
Controls and Indicators	12
Seat Latch and Adjustment	17
Driving Instructions	17
Bed Latch	20
Prop Rod	20
Front Shock Absorbers	21
Loading and Unloading	21
Towing with the Vehicle	22
Transporting on a Trailer	22
Storage	23
Maintenance	25
Daily Pre-Operation Safety Checklist	26
Periodic Service Schedule	27
Periodic Lubrication Schedule	28
Vehicle Capacities	29
Master Cylinder	30
Engine Oil	30
Fueling Instructions	31
Battery	32
Cleaning the Vehicle	33
Accessories	34
Subsequent Owner Registration	35
Vehicle Specifications	35

SAFETY DETAILS

⚠ WARNING

- THIS OWNER'S MANUAL SHOULD BE READ COMPLETELY BEFORE ATTEMPTING TO DRIVE OR SERVICE THE VEHICLE. FAILURE TO FOLLOW THE INSTRUCTIONS IN THIS MANUAL COULD RESULT IN PROPERTY DAMAGE, SEVERE PERSONAL INJURY, OR DEATH.

It is important to note that some vital statements throughout this manual and on the decals affixed to the vehicle are preceded by the words DANGER, WARNING, CAUTION, or NOTE. For your protection, we recommend that you take special notice of these safety procedures. Safety procedures are essential and must be followed.

If any of the operation or warning decals on the vehicle become damaged, have been removed, or cannot be easily read, they should be replaced immediately to avoid possible property damage, personal injury, or death. Contact your Club Car dealer.

⚠ DANGER

- A DANGER INDICATES AN IMMEDIATE HAZARD THAT WILL RESULT IN SEVERE PERSONAL INJURY OR DEATH.

⚠ WARNING

- A WARNING INDICATES AN IMMEDIATE HAZARD THAT COULD RESULT IN SEVERE PERSONAL INJURY OR DEATH.

⚠ CAUTION

- A CAUTION INDICATES HAZARDS OR UNSAFE PRACTICES THAT COULD RESULT IN MINOR PERSONAL INJURY OR PRODUCT OR PROPERTY DAMAGE.

NOTE

- A NOTE PROVIDES KEY INFORMATION TO MAKE PROCEDURES MORE EASILY UNDERSTOOD.

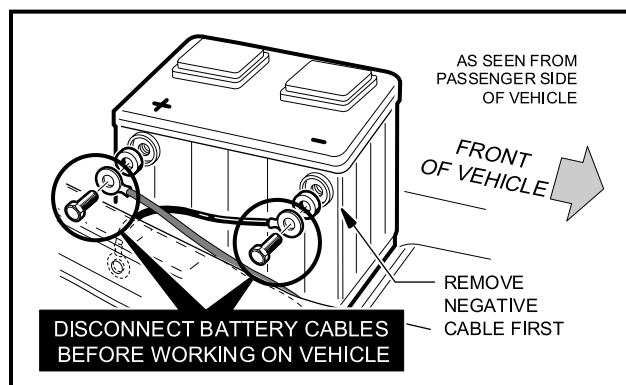

Figure 1 Battery Cable Removal

PIONEER 1200

⚠ WARNING

ROLLOVER OR FALLING OFF MAY CAUSE DEATH

- Read operators manual and operating instructions.
- Remain seated and hold on to seat handle while moving.
- Drive slowly in turns and straight up and down slopes.
- Do not start vehicle until all occupants are seated.
- One (1) person per seat maximum.
- Operate from driver side only and not on public roads.
- Keep entire body inside vehicle while moving.
- Do not operate while under the influence of alcohol or drugs.
- Never attempt jumps.

CCI 102029101

DASH WARNING DECAL

OPERATING INSTRUCTIONS

- Read Owner's Manual and safety warnings located on dash panel prior to driving.
 - Study and understand controls.
 - Make sure wheels are turned in desired direction.
- Turn key to "ON" position and be sure nothing is in your path.
 - While vehicle is stopped, select direction by placing shift lever or switch in desired position:
 - F - Forward N - Neutral R - Reverse (Buzzer will sound)
 - Release hand brake.
- Vehicle will start moving when accelerator pedal is depressed.
 - Slowly depress accelerator pedal to increase speed.
- To stop, release accelerator pedal and depress brake pedal.
 - After stopping, set hand brake.
- Place forward and reverse switch in neutral position.
 - Turn key "OFF" and remove key when not in use.

CCI 102029301

OPERATING INSTRUCTIONS DECAL

⚠ WARNING

REDUCED STEERING CONTROL MAY CAUSE SERIOUS INJURY OR DEATH

Disengage differential lock on paved surfaces.



CCI 102046601

DIFFERENTIAL LOCK CONTROL DECAL

UNDER 16

⚠ WARNING

YOUNG DRIVERS INCREASE CHANCE OF DEATH

- Young drivers may not be able to control vehicle.
- No drivers younger than 16 years old.
- Do not leave children unattended on vehicle.

CCI 102044601

UNDERAGE WARNING DECAL

OFF ON

KEY SWITCH

PARK BRAKE

⚠ WARNING

Riding in cargo bed can cause severe injury or death. Do not ride in cargo bed.



CCI 1015339-01

BED LOAD WARNING DECAL

LIGHT SWITCH

FUEL/HOUR GAUGE

SERIAL NUMBER

BRAKE PEDAL

OIL WARNING LIGHT

ACCELERATOR PEDAL

BED LATCH

CRUSH AREA DECAL

⚠ WARNING

CRUSH AREA



STAY CLEAR

CCI 1016094-01

(UNDER SEAT SUPPORT)

VEHICLE LOADING DECAL

<p>VEHICLE LOADING</p> <p>Read Owner's Manual and warnings on dash.</p>	<ul style="list-style-type: none"> • Vehicle rated capacity - 1200 lbs. on level surface only. Weight to include passengers, cargo bed load, and gross trailer weight. See Owner's Manual. • Maximum cargo load - 800 lbs. Weight to include cargo bed load and gross trailer weight. • Maximum trailer hitch tongue weight - 150 lbs. 	<ul style="list-style-type: none"> • Cargo should be evenly spread over the floor of the cargo bed as far forward as possible and secured. • For vehicle stability, when fully loaded, drive slowly and avoid stopping on or backing down steep hills. • Avoid top heavy loads. See Owner's Manual. • When driving on uneven terrain or down steep hills, reduce speed and load. <p>CCI 1019602-01</p>
--	---	--

PIONEER 1200

GASOLINE WARNING DECAL



(ON PASSENGER SIDE SEAT SUPPORT)

WINCH CABLE WARNING DECAL (FOR VEHICLES WITH WINCH ACCESSORY)

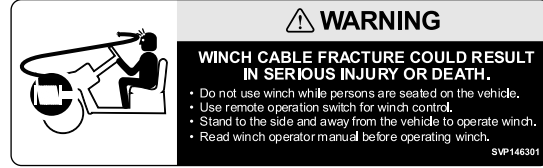

(ON SEAT SUPPORT PANEL)

ROTATING PARTS AND HOT MANIFOLD DECAL



(ON STARTER/GENERATOR AND ENGINE)

FORWARD/REVERSE HANDLE



PARK BRAKE

RECEIVER HITCH

TONGUE WEIGHT DECAL



(ON FRONT RECEIVER HITCH AND REAR TRAILER HITCH)

CHOKE

BED/LATCH WARNING DECAL



FRAME GROUND AND GOVERNOR WARNING DECAL



(ON FRAME)

GENERAL WARNINGS

The safety statements listed must be followed whenever the vehicle is being operated, repaired, or serviced. Vehicle feature identification information is also included beginning on page 8. Other specific WARNING statements appear throughout this manual and on the vehicle.

DANGER

- **GASOLINE VAPORS – BATTERY VAPORS – FLAMMABLE! EXPLOSIVE! DO NOT SMOKE. KEEP SPARKS AND FLAMES AWAY FROM VEHICLE AND SERVICE AREA. SERVICE ONLY IN WELL-VENTILATED AREAS.**
- **DO NOT OPERATE VEHICLE IN ENCLOSED AREA WITHOUT PROPER VENTILATION. THE ENGINE PRODUCES CARBON MONOXIDE, WHICH IS AN ODORLESS, DEADLY POISON.**
- **A UTILITY VEHICLE WILL NOT PROVIDE PROTECTION FROM LIGHTNING, FLYING OBJECTS, OR OTHER STORM-RELATED HAZARDS. IF CAUGHT IN A STORM WHILE DRIVING A UTILITY VEHICLE, EXIT THE VEHICLE AND SEEK SHELTER IN ACCORDANCE WITH APPLICABLE SAFETY GUIDELINES FOR YOUR LOCATION.**

WARNING

- DO NOT LEAVE CHILDREN UNATTENDED ON VEHICLE.
- WHEN STOPPING AND LEAVING THE VEHICLE:
 - TURN THE KEY SWITCH TO **OFF** AND REMOVE THE KEY.
 - PLACE THE FORWARD/REVERSE HANDLE IN **NEUTRAL**.
 - ENGAGE THE PARK BRAKE.
- ONLY TRAINED TECHNICIANS SHOULD REPAIR OR SERVICE THE VEHICLE. ANYONE DOING EVEN SIMPLE REPAIRS OR SERVICE SHOULD FOLLOW THE PROCEDURES EXACTLY AS STATED IN THIS MANUAL, AND FOLLOW ALL **DANGER**, **WARNING**, AND **CAUTION** STATEMENTS LISTED IN THIS MANUAL AS WELL AS THOSE AFFIXED TO THE VEHICLE.
- WEAR SAFETY GLASSES OR APPROVED EYE PROTECTION WHEN SERVICING THE VEHICLE. WEAR A FULL FACE SHIELD AND RUBBER GLOVES WHEN WORKING WITH BATTERIES.
- IMPROPER USE OF THE VEHICLE OR FAILURE TO PROPERLY MAINTAIN IT COULD RESULT IN DECREASED VEHICLE PERFORMANCE OR SEVERE PERSONAL INJURY.
- ANY MODIFICATION OR CHANGE TO THE VEHICLE THAT AFFECTS THE STABILITY OR HANDLING OF THE VEHICLE, OR INCREASES MAXIMUM VEHICLE SPEED BEYOND FACTORY SPECIFICATIONS COULD RESULT IN SEVERE PERSONAL INJURY OR DEATH.
- FOLLOW ALL PROCEDURES LISTED IN THIS MANUAL FOR LOADING AND UNLOADING THE VEHICLE. DO NOT EXCEED VEHICLE-RATED WEIGHT CAPACITY.
- PRIOR TO SERVICING THE VEHICLE:
 - TURN THE KEY SWITCH TO **OFF** AND REMOVE THE KEY.
 - PLACE THE FORWARD/REVERSE HANDLE IN **NEUTRAL**.
 - CHOCK THE WHEELS.
 - DISCONNECT THE BATTERY CABLES, NEGATIVE (–) FIRST (**FIGURE 1, PAGE 7**).
 - DISCONNECT THE SPARK PLUG WIRE FROM THE SPARK PLUG.
- USE INSULATED TOOLS WHEN WORKING AROUND BATTERY OR ELECTRICAL CONNECTIONS.
- FRAME GROUND. DO NOT ALLOW TOOLS OR OTHER METAL OBJECTS TO CONTACT FRAME WHEN DISCONNECTING BATTERY OR OTHER ELECTRICAL WIRING. NEVER ALLOW A POSITIVE WIRE TO TOUCH THE VEHICLE FRAME, ENGINE, OR OTHER METAL COMPONENT.

GENERAL INFORMATION

Throughout this manual, important vehicle information and features are highlighted. We urge the owner/operator to read and understand this manual.

MODEL IDENTIFICATION

The serial number of each Club Car vehicle is printed on a bar code decal mounted on the frame directly above the accelerator pedal (Example: QG0112-583947) (**Figure 2, Page 11**). There is also a second serial number decal mounted on the front body frame behind the dash panel. The dash panel must be removed to access it. **See following NOTE.**

NOTE

- ALWAYS HAVE THE VEHICLE SERIAL NUMBER AT HAND WHEN ORDERING PARTS OR MAKING INQUIRIES (**FIGURE 2, PAGE 11**).

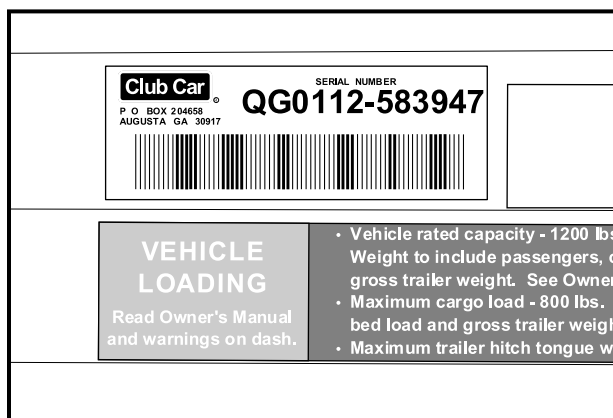

Figure 2 Serial Number

PRE-OPERATION CHECKLIST

Each Pioneer 1200 vehicle is thoroughly inspected and adjusted at the factory. However, upon arrival of your new vehicle, you should become familiar with its controls and operation, and carefully inspect each vehicle to be satisfied that it is in proper working condition before accepting delivery.

Use the following checklist as a guide to inspect the new vehicle. This checklist may also be used in conjunction with the Periodic Service Schedule on page 27. Any problems should be corrected only by your Club Car dealer or a trained technician.

- **General:** All the parts should be in place and properly installed. Be sure that all nuts, bolts, and screws are tight. Check hose clamps for tight fit and the starter belt for tightness.
- **Warning Decals:** Check to ensure that all warning and operation decals are in place. **See Pages 8 and 9.**
- **Tires:** Check for proper tire pressure. **See Tire Capacities, Page 29.**
- **Engine:** Check for proper engine oil level. **See Engine Oil, Page 30.**
- **Fuel:** Check fuel level. **See Fueling Instructions, Page 31.**
- **Hydraulic Brakes:** Check fluid level. **See Master Cylinder, Page 30.**

PERFORMANCE INSPECTION

After you have familiarized yourself with the vehicle's controls and have read and understood the driving instructions, take the vehicle for a test drive. Use the following checklist as a guide to inspect your new vehicle. Any problems should be corrected only by a Club Car dealer or a trained technician.

- **Brakes:** Be sure the brakes function properly. When brake pedal is fully depressed under **moderate** pressure, it should **not** go more than halfway to the floor, and vehicle should come to a smooth, straight stop. If the brake pedal goes more than halfway to the floor, or if the vehicle swerves or fails to stop, have the brake system checked and adjusted as required. When brake pedal is fully depressed under **heavy** pressure, pedal should feel firm and foot pad should be a minimum of 2 inches (5.1 cm) from floor. Brake adjustment must be maintained so the brake pedal **cannot** be depressed to the floor under any circumstance.
- **Park Brake:** Apply moderate pressure to park brake handle. Tension should increase as the handle is pulled. When latched, the park brake should lock the wheels and hold the vehicle stationary (on an incline of 20% or less).
- **Reverse Buzzer:** The reverse buzzer should sound as a warning when the Forward/Reverse handle is in REVERSE.
- **Steering:** The vehicle should be easy to steer and should not have any play in the steering wheel.
- **Accelerator:** With the key switch ON and the Forward/Reverse handle in the FORWARD position, as the accelerator pedal is depressed, the vehicle should accelerate smoothly to full speed. When the pedal is released it should return to the original position and the engine should idle until the key switch is turned to the OFF position. Club Car vehicles operate at reduced speed in reverse.
- **Governor:** Check the maximum speed of the vehicle. It should operate at 17-19 mph (27-31 km/h) on a level surface.
- **Differential Lock Cable:** With the wheels at rest, pull the differential lock handle toward the rear of the vehicle (locked position). The differential lock arm at the other end of the cable should move approximately one-half inch (12.7 mm) downward. When the differential lock handle is placed back into the unlocked position, the differential lock arm should move approximately one-half inch (12.7 mm) upward.
- **General:** Listen for any unusual noises such as squeaks or rattles. Check the vehicle's ride and performance. Have a Club Car dealer or a trained technician investigate anything unusual.

CONTROLS AND INDICATORS

Read **DANGER** and **WARNING** on page 10.

WARNING

- BEFORE ALLOWING ANYONE TO DRIVE THE VEHICLE, MAKE SURE THE DRIVER IS FAMILIAR WITH ALL CONTROLS AND OPERATING PROCEDURES.
- DO NOT TAMPER WITH THE GOVERNOR. DOING SO WILL VOID THE WARRANTY, AS WELL AS DAMAGE THE ENGINE AND OTHER COMPONENTS, AND COULD RESULT IN PROPERTY DAMAGE, PERSONAL INJURY, OR DEATH DUE TO UNSAFE SPEEDS.
- DO NOT MODIFY OR CHANGE THE VEHICLE IN ANY WAY THAT MIGHT AFFECT ITS STABILITY OR HANDLING, OR INCREASE MAXIMUM VEHICLE SPEED BEYOND FACTORY SPECIFICATIONS. PROPERTY DAMAGE, PERSONAL INJURY, OR DEATH COULD RESULT.
- DO NOT SHIFT THE FORWARD/REVERSE HANDLE WHILE THE VEHICLE IS IN MOTION.
- TO AVOID INJURY TO AN INATTENTIVE PASSENGER OR DAMAGE TO THE VEHICLE, ALWAYS BRING THE VEHICLE TO A FULL STOP BEFORE SHIFTING THE FORWARD/REVERSE HANDLE.

WARNING CONTINUED ON NEXT PAGE...

⚠ WARNING

- RELEASE THE ACCELERATOR PEDAL AND THEN DEPRESS THE BRAKE PEDAL FIRMLY UNTIL THE VEHICLE STOPS. TO AVOID UNINTENTIONALLY STARTING OR ROLLING THE VEHICLE, SET THE PARK BRAKE, TURN THE KEY SWITCH TO **OFF**, AND REMOVE THE KEY WHEN LEAVING THE VEHICLE.
- DO NOT EXCEED VEHICLE-RATED WEIGHT CAPACITY.
- WITH THE DIFFERENTIAL LOCK ENGAGED, VEHICLE TURNING FUNCTIONS ARE GREATLY REDUCED. TO PREVENT LOSS OF VEHICLE CONTROL WHEN DIFFERENTIAL LOCK IS ENGAGED, DO NOT OPERATE VEHICLE AT SPEEDS GREATER THAN HALF THROTTLE AND USE CAUTION WHEN ATTEMPTING TO TURN VEHICLE.

KEY SWITCH

The key switch is mounted on the dash to the right of the steering column (**Figure 3, Page 13**). It has two positions, OFF and ON, which are clearly labeled. To start the vehicle, turn the key switch to the ON position. The engine will start idling and continue to idle until the key is turned to the OFF position. **See following WARNING, CAUTION and NOTE.**

⚠ WARNING

- MOVING PARTS! KEEP CLEAR OF THE ENGINE COMPARTMENT WHILE THE ENGINE IS RUNNING.

⚠ CAUTION

- DO NOT “REV” THE ENGINE FOR LONG PERIODS OF TIME WHILE THE FORWARD/REVERSE HANDLE IS IN THE **NEUTRAL** POSITION. FAILURE TO HEED THIS CAUTION COULD RESULT IN DAMAGE TO THE UNITIZED TRANSAXLE.
- DO NOT SHIFT THE FORWARD/REVERSE HANDLE WHILE THE ACCELERATOR PEDAL IS PRESSED. SHIFT THE HANDLE ONLY WHEN THE KEY SWITCH IS IN THE **OFF** POSITION OR THE ENGINE IS AT IDLE. FAILURE TO HEED THIS CAUTION COULD RESULT IN DAMAGE TO THE UNITIZED TRANSAXLE.

NOTE

- THE KEY CAN BE REMOVED WHEN THE KEY SWITCH IS IN THE **OFF** POSITION ONLY.

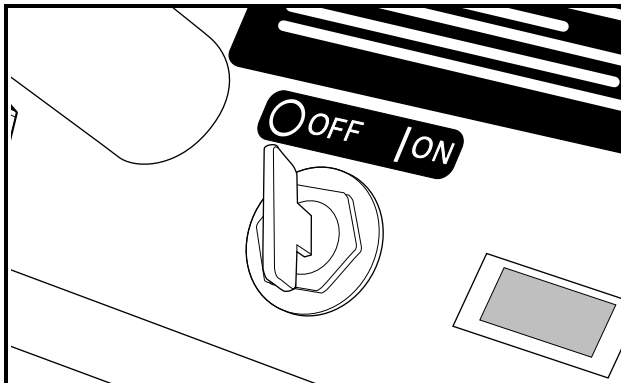

Figure 3 Key Switch

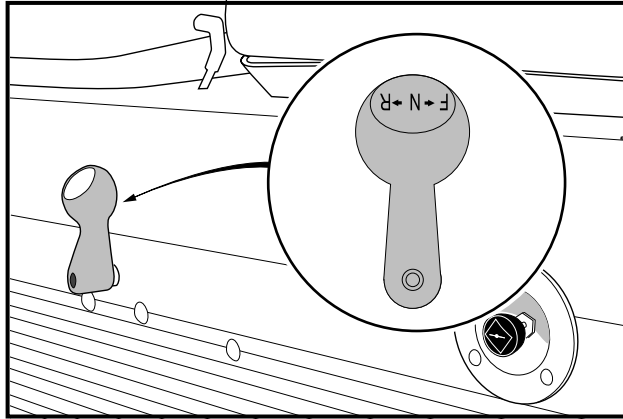

Figure 4 Forward/Reverse Handle

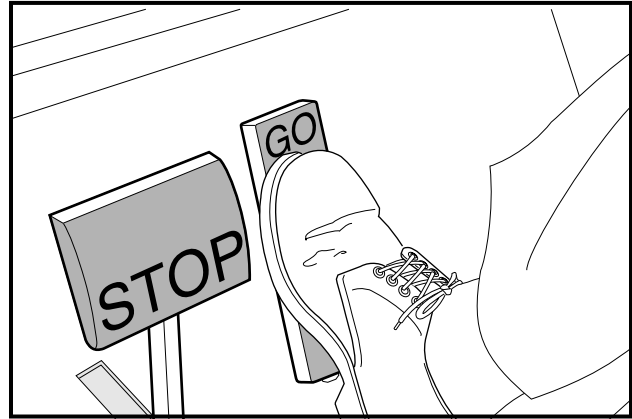

Figure 5 Accelerator and Brake Pedals

FORWARD/REVERSE CONTROL

The Forward/Reverse handle is located on the seat support panel (**Figure 4, Page 14**). The handle has three distinct positions: **F** (FORWARD), **N** (NEUTRAL), and **R** (REVERSE). Rotate the handle towards the driver, **F** (FORWARD), to operate the vehicle in the forward direction, or towards the passenger, **R** (REVERSE), to run the vehicle in reverse. When the handle is in the straight up, or **N** (NEUTRAL) position, the engine will idle. **See WARNING and CAUTION on page 13.** Club Car vehicles operate at a reduced speed in reverse. The reverse buzzer will sound as a warning when the Forward/Reverse handle is in REVERSE.

ACCELERATOR PEDAL

The accelerator pedal is the pedal on the right, with the word **GO** molded into it (**Figure 5, Page 14**). When the key switch is ON, the Forward/Reverse handle is in either FORWARD or REVERSE, and the park brake is released, depressing the accelerator pedal will start the vehicle moving in the direction selected. As the accelerator pedal is depressed, speed will increase until full speed is reached. When the accelerator is released, the engine will idle. **See WARNING and CAUTION on page 13.**

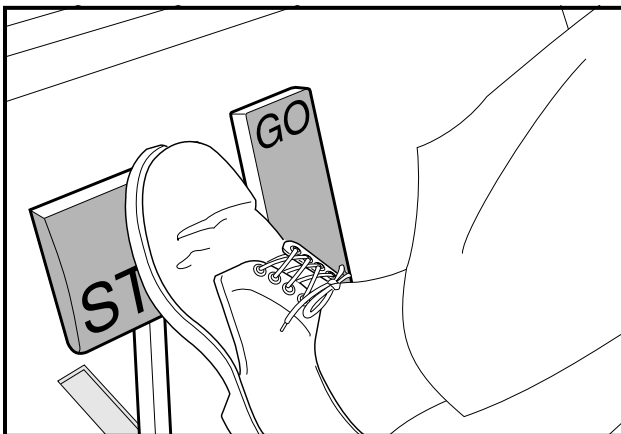

Figure 6 Brake Pedal

BRAKE PEDAL

The brake pedal is the large pedal on the left with the word **STOP** molded into it (**Figure 5, Page 14**). To slow or stop the vehicle, depress the brake pedal (**Figure 6, Page 14**).

PARK BRAKE

The park brake handle is located between the driver and passenger seats. To engage the park brake, first apply pressure to the brake pedal, and then pull up on the park brake handle until handle latches into place. To disengage, pull up on the handle and depress the button on the end of the handle. Push handle down. **See following WARNING.**

⚠ WARNING

- THE PARK BRAKE HAS MULTIPLE LOCKING POSITIONS AND SHOULD BE FIRMLY LOCKED TO PREVENT VEHICLE FROM ROLLING.

SERVICE CAM

The Pioneer 1200 is equipped with a service cam for use when service procedures are performed that require running the engine in neutral. The cam prevents the unintentional engagement of the transaxle, in the event that the Forward/Reverse handle is accidentally bumped or shifted. The service cam (red knob) is located on the back of the Forward/Reverse handle, inside the engine compartment. When the service cam is pulled out approximately 3/8 inch (10 mm) and then rotated one-half turn until it snaps into place, the cam will be in the SERVICE position (**Figure 7, Page 15**). With the cam in this position, the vehicle will not operate if the Forward/Reverse handle is placed in either the FORWARD or REVERSE position.

⚠ WARNING

- WITH THE CAM IN THE **SERVICE** POSITION AND THE ENGINE RUNNING, THE VEHICLE MAY MOVE SUDDENLY IF THE FORWARD/REVERSE HANDLE IS SHIFTED OR ACCIDENTALLY BUMPED. TO PREVENT THIS, CHOCK THE FRONT AND REAR WHEELS AND ALWAYS FIRMLY SET THE PARK BRAKE BEFORE SERVICING OR LEAVING THE VEHICLE.

To put the cam back into the OPERATE position, pull the cam out approximately 3/8 inch (10 mm) and rotate it one-half turn until it snaps into place (**Figure 8, Page 15**).

NOTE

- BE SURE TO RETURN THE CAM TO THE **OPERATE** POSITION AFTER SERVICING THE VEHICLE, OR IT WILL NOT RUN WITH THE FORWARD/REVERSE HANDLE IN EITHER THE **FORWARD** OR **REVERSE** POSITION.

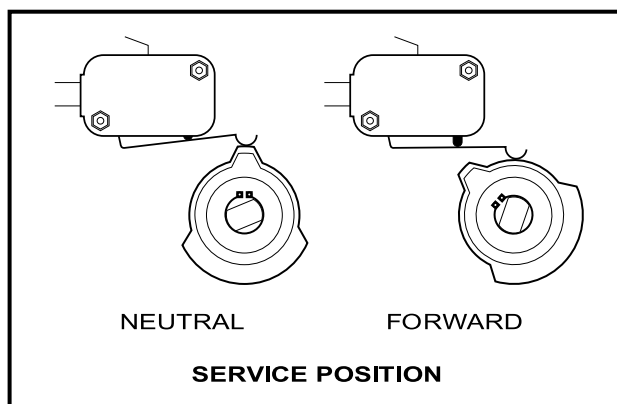

Figure 7 Service Cam – Service Position

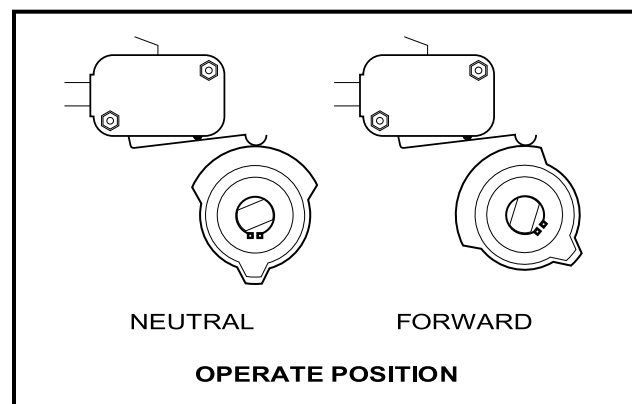

Figure 8 Service Cam – Operate Position

CHOKE

The choke is located on the seat support panel below and to the left of the driver's left knee. If the vehicle is hard to start in cool or cold temperatures, activate choke: Pull the choke handle out to activate. Release the handle when the engine begins to run smoothly (**Figure 9, Page 16**).

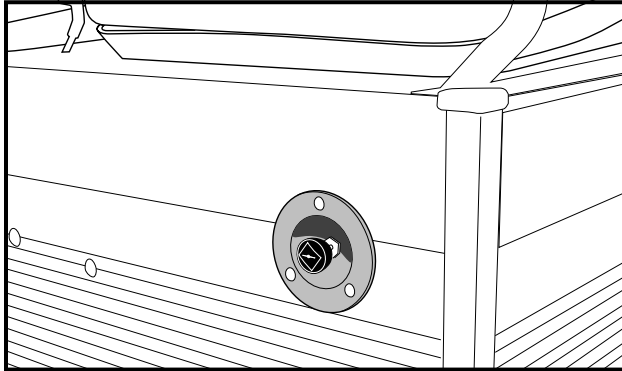

Figure 9 Choke

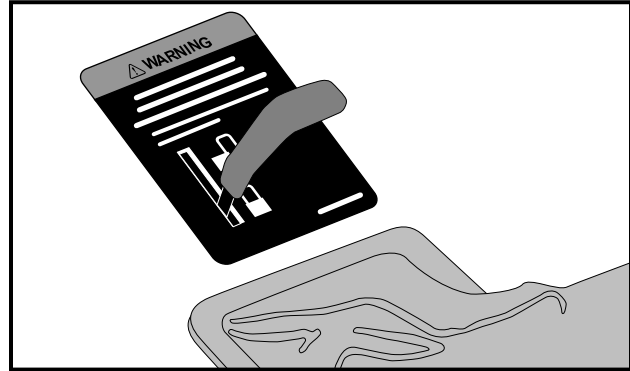

Figure 10 Differential Lock

DIFFERENTIAL LOCK

⚠ WARNING

- WITH THE DIFFERENTIAL LOCK ENGAGED, VEHICLE TURNING FUNCTIONS ARE GREATLY REDUCED. TO PREVENT LOSS OF VEHICLE CONTROL WHEN DIFFERENTIAL LOCK IS ENGAGED, DO NOT OPERATE VEHICLE AT SPEEDS GREATER THAN HALF THROTTLE AND USE CAUTION WHEN ATTEMPTING TO TURN VEHICLE.
- DISENGAGE DIFFERENTIAL LOCK ON PAVED SURFACES.

The differential lock is used to provide better traction at the rear wheels when necessary. Engaging the differential lock will transfer power to both rear wheels simultaneously (**Figure 10, Page 16**).

1. To engage the differential lock, slow the vehicle to no more than half throttle and pull differential lock handle toward the back of the vehicle. The differential lock will engage when power to both rear wheels is required.
2. To disengage the differential lock, come to a complete stop, then push lever toward front of vehicle.

OIL LIGHT

The Pioneer 1200 vehicle is equipped with a low oil warning light, located on the dash panel just to the right of the steering column and key switch (**Figure 11, Page 17**). If the oil warning light comes on, oil should be checked and added to the engine as necessary before continuing to use the vehicle. The vehicle should never be driven when the oil warning light remains on. If the oil warning light goes on and off, the vehicle may be driven, but oil should be added at the first opportunity. If the oil level is correct and the light stays on, have a trained technician check the vehicle. **See following CAUTION.**

⚠ CAUTION

- FAILURE TO ADD OIL IMMEDIATELY WHEN THE OIL WARNING LIGHT STAYS ON MAY RESULT IN PERMANENT ENGINE DAMAGE.

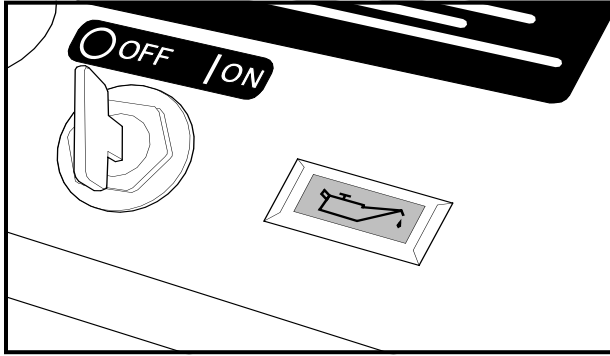

Figure 11 Oil Light

FUEL/HOUR GAUGE

The Pioneer 1200 is equipped with a fuel/hour gauge, located on the dash panel. The fuel gauge allows the operator to monitor the fuel level in the vehicle. The hour gauge should be used by the trained technician in order to track vehicle usage and determine when periodic service procedures are required. **See Periodic Service Schedule on page 27.**

HEADLIGHT CONTROL

The headlight control is located on the front dash between the fuel/hour gauge and steering column. Pull the headlight control knob out to turn headlights on and push the knob in to turn headlights off.

NOTE

- USING THE HEADLIGHTS FOR EXTENDED PERIODS OF TIME WITHOUT THE ENGINE RUNNING, OR WITH THE ENGINE IDLING WILL DISCHARGE THE BATTERY.

SEAT LATCH AND ADJUSTMENT

Pioneer 1200 seats are hinged to allow easy access to the engine compartment. A latch at the rear of each seat bottom keeps the seat from moving on its hinges while the vehicle is in operation. To disengage the latch, grasp the seat back and pull firmly in a forward/upward direction until the latch releases. To engage the seat latch, push down firmly on the seat back until the seat locks into place.

The seats are adjustable and can be moved forward or backward to accommodate the driver or passenger. To adjust a seat:

1. Remove the seat from the vehicle.
2. Remove the four bolts and washers from the bottom of the seat mounting plate.
3. Align the mounting plate holes with holes in the seat to achieve the desired seat position.
4. Install washers and bolts and tighten to 96 in-lb (10.8 N·m).
5. Reinstall seat in vehicle.

⚠ WARNING

- MAKE SURE SEAT HINGES AND LATCH ARE SECURELY ENGAGED BEFORE OPERATING VEHICLE.

DRIVING INSTRUCTIONS

No one should drive the vehicle without first being instructed in the proper operation and use of vehicle controls. An experienced operator should accompany each first-time driver on a test drive before allowing the driver to operate the vehicle alone.

⚠ WARNING

- ONLY LICENSED DRIVERS SHOULD BE ALLOWED TO DRIVE THIS VEHICLE.
- BEFORE ALLOWING A CLUB CAR VEHICLE TO BE DRIVEN, MAKE SURE THE DRIVER IS FAMILIAR WITH ALL CONTROLS AND OPERATING PROCEDURES.
- NO ONE UNDER THE AGE OF 16 YEARS SHOULD BE ALLOWED TO DRIVE THE VEHICLE.
- NO MORE THAN ONE PERSON PER SEAT AT ONE TIME.
- DO NOT ALLOW RIDERS IN THE CARGO BED.
- FOR NIGHT USE, THE VEHICLE MUST BE EQUIPPED WITH HEADLIGHTS, TAILLIGHTS, AND REFLECTORS.
- THE VEHICLE IS NOT SPECIALLY EQUIPPED FOR HANDICAPPED PERSONS:
 - BE SURE ALL PASSENGERS ARE CAPABLE OF SECURING THEMSELVES IN A MOVING CLUB CAR VEHICLE BEFORE ALLOWING THEM TO RIDE IN ONE.
 - BE SURE ALL PERSONS CAN PROPERLY OPERATE THE VEHICLE PRIOR TO ALLOWING THEM TO DRIVE THE VEHICLE.
- STOP THE VEHICLE BEFORE SHIFTING THE FORWARD/REVERSE HANDLE. FAILURE TO DO SO MAY RESULT IN INJURY TO INATTENTIVE PASSENGERS AND (OR) DAMAGE TO THE VEHICLE.
- TO AVOID BEING STRUCK, DO NOT STAND IN FRONT OF OR BEHIND THE VEHICLE.
- DO NOT LEAVE CHILDREN UNATTENDED IN THE VEHICLE.

WHEN DRIVING THE VEHICLE:

- OPERATE THE VEHICLE FROM THE DRIVER SEAT ONLY.
- TO PREVENT FALLS FROM THE VEHICLE, REMAIN SEATED AND HOLD ON TO SEAT HANDLES AT ALL TIMES. DRIVER SHOULD KEEP BOTH HANDS ON THE STEERING WHEEL WHEN THE VEHICLE IS IN MOTION.
- TO PREVENT THE POSSIBILITY OF SERIOUS INJURY, KEEP ENTIRE BODY INSIDE THE VEHICLE.
- TO PREVENT OVERTURNING THE VEHICLE, DRIVE SLOWLY AROUND TURNS.
- TO PREVENT OVERTURNING THE VEHICLE, DRIVE SLOWLY STRAIGHT UP AND DOWN SLOPES. **AVOID DRIVING THE VEHICLE ON SLOPES EXCEEDING 20% INCLINE.**
- AVOID STOPPING A LOADED VEHICLE ON A HILL. IF A LOADED VEHICLE MUST BE STOPPED ON A HILL, AVOID SUDDEN STARTS OR ROLLING BACKWARDS AND STOPPING SUDDENLY. FAILURE TO HEED THIS WARNING COULD RESULT IN OVERTURNING THE VEHICLE.
- TO AVOID POSSIBLE INJURY TO INATTENTIVE PASSENGERS AND (OR) DAMAGE TO THE VEHICLE, AVOID SUDDEN STARTS, SUDDEN STOPS, AND ABRUPT TURNS.
- TO AVOID THE POSSIBILITY OF LOSING CONTROL OF OR OVERTURNING THE VEHICLE, REDUCE SPEED FOR ADVERSE DRIVING CONDITIONS SUCH AS WET GRASS OR ROUGH TERRAIN.
- DO NOT USE THE VEHICLE ON PUBLIC ROADS. IT IS NEITHER DESIGNED NOR INTENDED FOR STREET USE AND SHOULD NOT BE LICENSED FOR USE ON PUBLIC ROADS.
- THE VEHICLE SHOULD BE DRIVEN IN ONLY SPECIFIED AREAS BY TRAINED DRIVERS.
- DO NOT DRIVE WHILE UNDER THE INFLUENCE OF ALCOHOL, DRUGS, OR MEDICATIONS.
- USE BRAKES TO REDUCE SPEED WHEN COASTING DOWNHILL.
- NEVER ATTEMPT JUMPS.

To ensure safe operation of the vehicle, follow exactly and in order, all of the following procedures. Read and understand all instructions prior to driving the vehicle.

STARTING THE VEHICLE

1. Read safety warnings on dash and vehicle loading information located above pedals.
2. Be sure load, if any, is secure.
3. Study and understand controls.
4. Be sure passenger is seated and holding on to armrest. Driver should have both hands on the steering wheel.
5. Make sure wheels are turned in desired direction and nothing is in your path.
6. Make sure the Forward/Reverse handle is in the NEUTRAL position.
7. Depress and hold the brake pedal.
8. Turn the key switch to the ON position. The engine will idle.
9. Release hand brake.
10. While keeping the brake engaged, select direction of travel by placing shift handle in desired position (F = forward or R = reverse). A buzzer will sound as a warning when the Forward/Reverse handle is in REVERSE.
11. Release the brake pedal completely, and then slowly depress the accelerator pedal. As the accelerator is depressed, speed will increase until full speed is reached.

WARNING

- THE DRIVER MUST CONTROL VEHICLE SPEED WHEN GOING DOWNHILL.
- NEVER SHIFT THE VEHICLE OUT OF **FORWARD** WHILE GOING DOWNHILL. IF YOU DO, YOU WILL NOT BE ABLE TO SHIFT INTO **REVERSE** OR BACK INTO **FORWARD** UNTIL STOPPED.
- DEPRESS THE BRAKE PEDAL AS NECESSARY AND DEPRESS THE ACCELERATOR PEDAL PARTIALLY WHEN DESCENDING A HILL. WITH THE ACCELERATOR PEDAL PARTIALLY DEPRESSED, THE GOVERNOR WILL CAUSE THE ENGINE TO ASSIST THE BRAKES IN CONTROLLING DOWNHILL SPEED.

STOPPING THE VEHICLE

WARNING

- DRIVING THROUGH WATER MAY AFFECT THE BRAKES. AFTER DRIVING THROUGH WATER, CHECK EFFECTIVENESS OF THE BRAKES BY GENTLY DEPRESSING THE BRAKE PEDAL. IF THE VEHICLE DOES NOT SLOW DOWN AT THE NORMAL RATE, CONTINUE TO DEPRESS THE BRAKE PEDAL UNTIL THE BRAKES DRY OUT AND NORMAL PERFORMANCE RETURNS.

CAUTION

- WHEN STOPPED ON A HILL, USE THE BRAKE PEDAL TO HOLD YOUR POSITION. DO NOT USE THE ACCELERATOR PEDAL.

To stop the vehicle, release the accelerator pedal and depress the brake pedal until the vehicle comes to a complete stop.

PARKING AND LEAVING THE VEHICLE

1. After stopping the vehicle, set hand brake until it locks. **Make sure it is fully engaged.** This will prevent the vehicle from rolling.
2. Turn the key switch to OFF and place the Forward/Reverse handle in the NEUTRAL position. Remove the key, and turn the fuel shut-off valve to closed (OFF) position when the vehicle is not in use (**Figure 14, Page 25**). **See also Figure 21.**

BED LATCH

Read **DANGER** and **WARNING** on page 10.

The vehicle is equipped with a bed latch on the driver side of the vehicle (**Figure 12, Page 20**) and an automatically engaging prop rod (**Figure 13, Page 20**). To lift the bed, pull the latch handle toward the rear of the vehicle and lift the bed. To close the bed, disengage the prop rod and gently lower the bed until the bed latch engages. **DO NOT** drop the bed.

⚠ WARNING

- KEEP HANDS CLEAR OF CRUSH AREA BETWEEN BED AND VEHICLE BODY.

NOTE

- THE VEHICLE IS EQUIPPED WITH AN AUTOMATICALLY ENGAGING PROP ROD (**FIGURE 13, PAGE 20**), UNLESS EQUIPPED WITH THE HYDRAULIC OR ELECTRIC BED LIFT ACCESSORY.

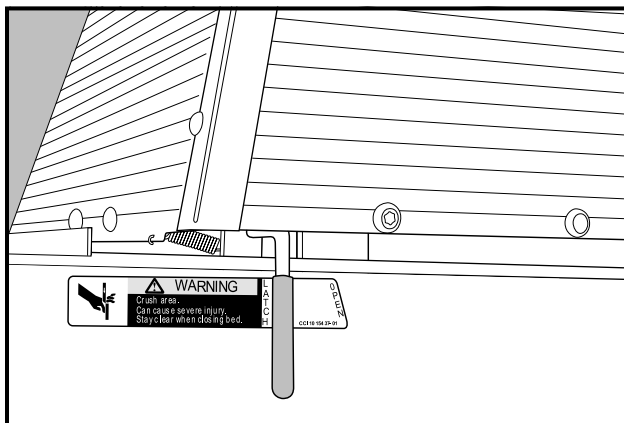

Figure 12 Bed Latch

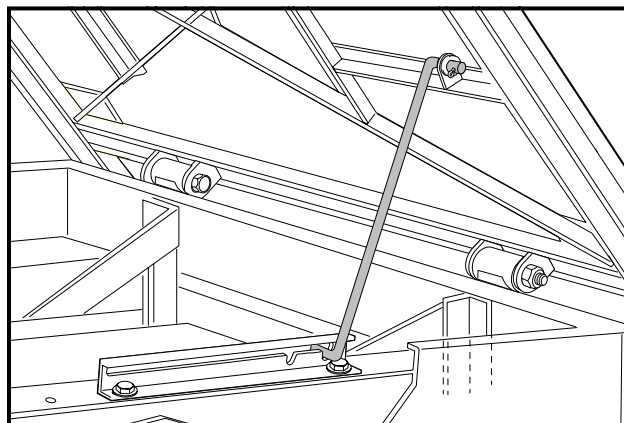

Figure 13 Prop Rod

PROP ROD

Read **DANGER** and **WARNING** on page 10.

The vehicle is equipped with an automatically engaging prop rod and prop rod track on the driver side of the rear body (**Figure 13, Page 20**). When pulling the bed latch handle and lifting the bed, the prop rod will come to rest in one of the notches in the prop rod track.

⚠ DANGER

- USE CAUTION WHEN WORKING UNDER BED. BE SURE PROP ROD IS SECURE. OTHERWISE THE BED WILL FALL, RESULTING IN SEVERE PERSONAL INJURY OR DEATH.

⚠ WARNING

- **DO NOT** DISENGAGE PROP ROD UNTIL ALL PERSONS ARE CLEAR OF CARGO BED AREA.
- **DO NOT** DROP TILT BED; LOWER GENTLY AND KEEP ENTIRE BODY CLEAR. FAILURE TO FOLLOW THESE INSTRUCTIONS COULD RESULT IN SEVERE INJURY.
- KEEP HANDS CLEAR OF CRUSH AREA BETWEEN BED AND VEHICLE BODY.

To lower the bed, lift the bed so that the prop rod is no longer supported in one of the track notches. Push the prop rod toward the front of the vehicle to free it from the track notch and gently lower the bed. Once the bed is halfway down, remove hand from prop rod and continue lowering the bed gently until the bed latch engages. DO NOT drop the bed.

FRONT SHOCK ABSORBERS

The vehicle arrives from the factory with the front coil-over shocks pre-adjusted for optimum vehicle performance.

CAUTION

- DO NOT ADJUST THE FRONT SHOCK ABSORBERS. DAMAGE TO THE FRAME OR OTHER COMPONENTS COULD RESULT.

LOADING AND UNLOADING

When loading the vehicle, center and secure cargo as far forward as possible in the cargo bed. Do not overload the vehicle. The total capacity of the vehicle is 1200 lb. (544 kg). This includes passengers and a maximum cargo bed capacity of 800 lb. (363 kg). Trailer tongue weight must never exceed 150 lb. and the sum of the trailer gross weight and tongue weight must never exceed 800 lb. (363 kg).

Compare the calculated value for the total load. Cargo load should never exceed maximum rated capacity.

See following WARNING.

WARNING

- FIRMLY ENGAGE THE PARK BRAKE BEFORE LOADING THE VEHICLE.
- DO NOT ALLOW RIDERS IN THE CARGO BED.
- REDUCE VEHICLE LOAD AND SPEED WHEN DRIVING UP OR DOWN SLOPES OR ON UNEVEN TERRAIN.
- DO NOT EXCEED THE RATED CAPACITY OF THE VEHICLE. RATED CAPACITY IS FOR LEVEL SURFACES ONLY.
- OVERLOADING CAN AFFECT VEHICLE HANDLING OR CAUSE COMPONENT FAILURE, RESULTING IN LOSS OF CONTROL OF VEHICLE AND POSSIBLE SEVERE PERSONAL INJURY.
- REDUCE SPEED AND AVOID SUDDEN STOPS WHEN BACKING UP. FAILURE TO DO SO MAY CAUSE THE VEHICLE TO OVERTURN OR FLIP OVER BACKWARDS.
- AVOID STOPPING ON A HILL WHEN LOADED. IF YOU MUST STOP ON A HILL, AVOID SUDDEN STARTS, OR ROLLING BACKWARDS AND STOPPING SUDDENLY. FAILURE TO HEED THIS WARNING MAY CAUSE VEHICLE TO OVERTURN, POSSIBLY RESULTING IN SEVERE PERSONAL INJURY.
- VEHICLE LOAD AND SPEED MUST BE REDUCED WHEN DRIVING UP OR DOWN SLOPES OR ON UNEVEN TERRAIN.
- DO NOT LOAD THE TAILGATE. THE TAILGATE SHOULD BE IN THE UPRIGHT POSITION AND LATCHED SECURELY WHILE THE VEHICLE IS IN MOTION.
- TO AVOID SHIFTING THE VEHICLE LOAD AND POSSIBLY OVERTURNING THE VEHICLE, AVOID SUDDEN STARTS, SUDDEN STOPS, AND ABRUPT TURNS. MAKE SURE CARGO IS WELL SECURED.
- THE CARGO'S CENTER OF GRAVITY MAY AFFECT THE HANDLING, STEERING, AND BRAKING OF THE VEHICLE.

WARNING CONTINUED ON NEXT PAGE...

⚠ WARNING

- AVOID TOP-HEAVY LOADS. THE CENTER OF GRAVITY OF A LOAD SHOULD NEVER EXCEED 15 INCHES (38 CM) ABOVE THE BOTTOM OF THE CARGO BED.
- ALWAYS UNLOAD CARGO BED BEFORE RAISING VEHICLE WITH A LIFT, HOIST, OR JACK.

TOWING WITH THE VEHICLE**⚠ WARNING**

- NEVER TOW A VEHICLE OR TRAILER ON PUBLIC STREETS OR HIGHWAYS.
- NORMAL VEHICLE OPERATING SPEED SHOULD BE REDUCED WHEN TOWING.
- EXTREME CAUTION SHOULD BE USED WHEN TOWING.
- DO NOT ALLOW RIDERS IN THE VEHICLE OR TRAILER BEING TOWED.
- TOTAL VEHICLE CAPACITY, INCLUDING THE VEHICLE LOAD RATING AND THE GROSS WEIGHT OF THE VEHICLE OR TRAILER BEING TOWED SHOULD NOT EXCEED THE WEIGHT PREVIOUSLY SPECIFIED.
- AVOID SUDDEN STARTS, SUDDEN STOPS, AND TIGHT TURNS WHEN TOWING.
- AVOID STOPPING ON A HILL WHEN TOWING. IF YOU MUST STOP ON A HILL, AVOID SUDDEN STARTS, OR ROLLING BACKWARDS AND STOPPING SUDDENLY. FAILURE TO HEED THIS WARNING COULD CAUSE VEHICLE TO OVERTURN, POSSIBLY RESULTING IN SEVERE PERSONAL INJURY.

Because towing another Club Car vehicle or a trailer can have adverse effects on vehicle handling, be especially cautious when towing with a Club Car vehicle. Total vehicle capacity, including the tow vehicle load rating and the gross weight of the vehicle with a trailer being towed should not exceed 1200 lb. (544 kg). Never exceed a trailer tongue weight of 150 lb. (68 kg) for any Pioneer 1200 vehicle.

Parking the vehicle with a trailer on a hill should be avoided. If you must park on a hill, apply the brakes and have someone chock the tires of the trailer. Brakes should be released to allow the chocks to absorb the load of the trailer. After the tires have been chocked, engage the park brake.

TRANSPORTING ON A TRAILER

Use an approved trailer that has a load rating of at least 1600 lb. (727 kg) per vehicle to be towed. For example, a two-car trailer should be rated at $2 \times 1600 = 3200$ lb. ($2 \times 727 = 1454$ kg).

If the vehicle must be transported over long distances or on public highways, it should be transported on an approved trailer observing all the following warning procedures:

⚠ WARNING

- TURN FUEL SHUT-OFF VALVE TO CLOSED (**OFF**) POSITION (**FIGURE 14, PAGE 25**).
- DO NOT ALLOW RIDERS IN THE TRAILER BEING TOWED.
- AVOID SUDDEN STARTS, SUDDEN STOPS, AND TIGHT TURNS WHEN TOWING.

WARNING CONTINUED ON NEXT PAGE...

⚠ WARNING

- AVOID STOPPING ON A HILL WHEN TOWING. IF YOU MUST STOP ON A HILL, AVOID SUDDEN STARTS, OR ROLLING BACKWARDS AND STOPPING SUDDENLY. FAILURE TO HEED THIS WARNING COULD CAUSE THE VEHICLE TO OVERTURN, POSSIBLY RESULTING IN SEVERE PERSONAL INJURY.
- REDUCE NORMAL DRIVING SPEED WHEN TRANSPORTING A VEHICLE OR TRAILER.
- FOR USE ON PUBLIC ROADS, THE TRAILER MUST MEET ALL FEDERAL, STATE, AND LOCAL REQUIREMENTS SUCH AS TAILLIGHTS, BRAKE LIGHTS, ETC.
- NEVER TOW A CLUB CAR VEHICLE BEHIND A PASSENGER VEHICLE OR TRUCK ON A PUBLIC ROAD UNLESS IT IS ON AN APPROVED TRAILER.
- THE VEHICLE TO BE TRANSPORTED SHOULD BE TIED SECURELY TO THE TRAILER, WITH THE FORWARD/REVERSE HANDLE IN **NEUTRAL**, THE KEY SWITCH **OFF**, AND THE PARK BRAKE FIRMLY ENGAGED.
- BECAUSE OF THE ADDED LENGTH OF THE TRAILER, USE CAUTION WHEN MAKING TURNS.
- NEVER TRANSPORT THE VEHICLE ON A TRAILER WITH A LOAD IN THE VEHICLE CARGO BED.
- REMOVE THE VEHICLE WINDSHIELD BEFORE TRANSPORTING ON A TRAILER.

STORAGE

Read **DANGER** and **WARNING** on page 10.

To prepare the vehicle for extended storage:

1. Unload the vehicle completely, so that only minimum vehicle weight will be placed on the tires.
2. Store vehicle in a cool place. This will minimize self-discharge of the battery. If the battery appears to be weak, have it charged using an automotive-type 12-volt battery charger rated at 10 amps or less.

⚠ DANGER

- **NEVER ATTEMPT TO DRAIN GASOLINE WHEN THE ENGINE IS HOT OR WHILE IT IS RUNNING.**
- **BE SURE TO CLEAN UP ANY SPILLED GASOLINE BEFORE OPERATING THE VEHICLE.**
- **STORE GASOLINE IN AN APPROVED GASOLINE CONTAINER ONLY. STORE IN A WELL-VENTILATED AREA AWAY FROM SPARKS, OPEN FLAMES, HEATERS, OR HEAT SOURCES.**
- **KEEP GASOLINE OUT OF THE REACH OF CHILDREN.**
- **DO NOT SIPHON GASOLINE FROM THE VEHICLE.**

⚠ WARNING

- TURN THE KEY SWITCH **OFF**, REMOVE THE KEY, AND LEAVE THE FORWARD/REVERSE HANDLE IN THE **NEUTRAL** POSITION DURING STORAGE. THIS IS TO PREVENT UNINTENTIONALLY STARTING THE VEHICLE OR A FIRE HAZARD.
- TURN FUEL SHUT-OFF VALVE TO CLOSED (**OFF**) POSITION (**FIGURE 14, PAGE 25**).
- DO NOT ATTEMPT TO CHARGE A BATTERY IF IT IS FROZEN OR IF THE CASE IS BULGED. DISCARD THE BATTERY. FROZEN BATTERIES CAN EXPLODE.

CAUTION

- BATTERIES IN A LOW STATE OF CHARGE WILL FREEZE AT LOW TEMPERATURES.

3. Drain carburetor and seal the fuel tank.
 - 3.1. Place the Forward/Reverse handle in the NEUTRAL position and the service cam in the SERVICE position. Turn the fuel shut-off valve to the closed (OFF) position (**Figure 14, Page 25**) and run the engine until fuel remaining in the carburetor and fuel lines is used up and the engine stalls. Return the service cam to the OPERATE position.
 - 3.2. Loosen (do not remove) the carburetor drain screw and drain fuel remaining in bowl into a small container, then pour the fuel from the container into vehicle fuel tank. Tighten the carburetor drain screw.
 - 3.3. Fill fuel tank to about 1 inch (2.5 cm) from top of fuel tank and, following manufacturer's directions, add a commercially available fuel stabilizer (such as Sta-Bil[®]).
 - 3.4. Disconnect fuel vent line from fuel tank vent nipple.
 - 3.5. Plug the fuel tank vent nipple so that it is air tight. We recommend using a slip-on vinyl cap.
4. To protect the engine, remove spark plug and pour 1/2 ounce of SAE 10 weight oil into the engine through the spark plug hole. Rotate engine crankshaft by hand several times and then re-install the spark plug.
5. Inflate tires to rated capacities. **See Tire Capacities, Page 29.**
6. Grease front suspension and do all other semiannual periodic lubrication. **See Periodic Lubrication Schedule, Page 28.**
7. Thoroughly clean front body, rear body, seats, cargo bed, engine compartment, and underside of vehicle.
8. Do not engage the park brake. Block tires to prevent the vehicle from rolling.

TO RETURN THE STORED VEHICLE TO SERVICE

1. Restore fuel system to operation.
 - 1.1. Remove plug from the fuel tank vent nipple and open the fuel shut-off valve (**Figure 15, Page 25**). Make sure the valve is fully open. A partially closed fuel shut-off valve (**Figure 16, Page 25**) combined with the use of the choke, can result in a fouled spark plug and engine failure.
 - 1.2. Place the Forward/Reverse handle in the NEUTRAL position and the service cam in the SERVICE position. Crank the engine until fuel is pumped into the carburetor and fuel lines and the engine starts. Turn the engine off and return the service cam to the OPERATE position.
2. Readjust tire pressure. **See Tire Capacities, Page 29.**
3. Perform the Pre-Operation Checklist. **See page 11.**

NOTE

- DUE TO THE OIL ADDED TO THE ENGINE IN PREPARATION FOR STORAGE, ENGINE MAY SMOKE EXCESSIVELY FOR A SHORT WHILE WHEN RUNNING IT FOR THE FIRST TIME AFTER STORAGE.

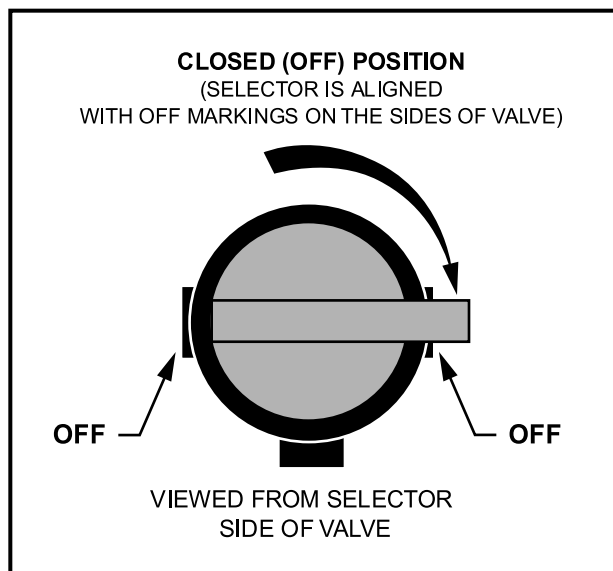

Figure 14 Fuel Shut-off Valve – Closed Position

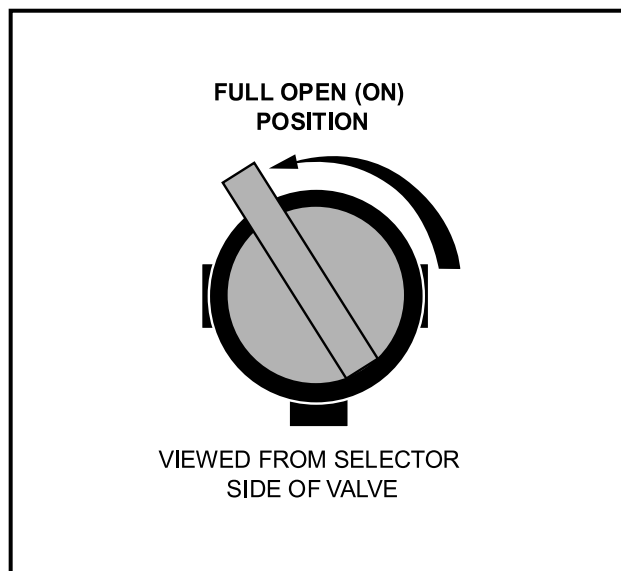

Figure 15 Fuel Shut-off Valve – Open Position

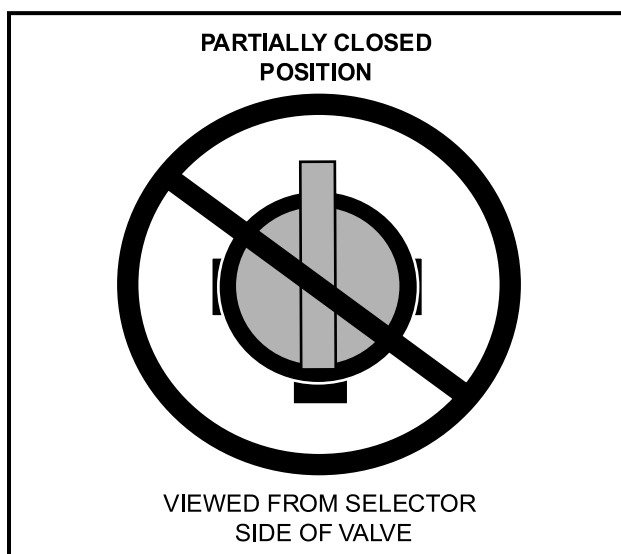

Figure 16 Incorrect Fuel Shut-off Valve Setting

MAINTENANCE

Read **DANGER** and **WARNING** on page 10.

GENERAL INFORMATION

To ensure trouble-free vehicle performance, it is very important to follow an established preventive maintenance program (regularly scheduled service – see page 27). Regular and consistent vehicle maintenance can prevent vehicle down-time and expensive repairs that result from neglect. Any vehicle not functioning correctly should be removed from use until it is properly repaired. This will prevent further damage to the vehicle and avoid the possibility of injury due to unsafe conditions.

Contact your local Club Car dealer to perform all repairs and semiannual and annual periodic service.

⚠ WARNING

- IF ANY PROBLEMS ARE FOUND DURING SCHEDULED INSPECTION OR SERVICE, DO NOT OPERATE THE VEHICLE UNTIL REPAIRS ARE MADE. FAILURE TO MAKE NECESSARY REPAIRS COULD RESULT IN FIRE, PROPERTY DAMAGE, SEVERE PERSONAL INJURY, OR DEATH.
- DO NOT WEAR LOOSE CLOTHING OR JEWELRY, SUCH AS RINGS, WATCHES, CHAINS, ETC., WHEN SERVICING THE VEHICLE.
- TURN KEY SWITCH TO **OFF**, REMOVE THE KEY, PLACE THE FORWARD/REVERSE HANDLE IN THE **NEUTRAL** POSITION, AND CHOCK THE WHEELS PRIOR TO SERVICING.
- MOVING PARTS – DO NOT ATTEMPT TO SERVICE VEHICLE WHILE THE ENGINE IS RUNNING.
- DO NOT WORK ON VEHICLE POWERTRAIN OR UNDER THE CARGO BED WHEN IT IS LOADED.
- TURN FUEL SHUT-OFF VALVE TO CLOSED (**OFF**) POSITION (**FIGURE 14, PAGE 25**).
- **HOT!** DO NOT ATTEMPT TO SERVICE HOT ENGINE OR EXHAUST SYSTEM. ATTEMPTING TO DO SO COULD CAUSE SEVERE BURNS.
- DO NOT REMOVE PROP ROD OR CLOSE BED UNTIL ALL PERSONS ARE CLEAR OF THE BED AREA. LOWER THE BED GENTLY, KEEPING ENTIRE BODY CLEAR. DO NOT DROP THE BED. FAILURE TO FOLLOW THESE INSTRUCTIONS COULD RESULT IN SEVERE PERSONAL INJURY.
- A HYDRAULIC BED LIFT SYSTEM IS UNDER PRESSURE. WEAR A FACE SHIELD AND USE EXTREME CAUTION WHEN SERVICING IT.

DAILY PRE-OPERATION SAFETY CHECKLIST

Inspect and drive the vehicle, using the Pre-operation Checklist (Page 11) and Performance Inspection (Page 12) as guides to check the following items.

- Vehicle warning decals
- Brake system
- Park brake
- Reverse warning buzzer
- Steering and linkages
- Proper acceleration and maximum speed
- Differential lock cable

In addition, check the items listed below:

- Tires: Visually inspect for wear, damage and proper inflation.
- Exhaust system: Check for leaks.
- Forward/Reverse shifter: Check for proper operation. **See Controls and Indicators, Page 12.**
- Fuel system: Check fuel tank, lines, cap, pump, fuel filters, and carburetor for fuel leakage.

PERIODIC SERVICE SCHEDULE

Read **DANGER** and **WARNING** on page 10.

WARNING

- SERVICE, REPAIRS, AND ADJUSTMENTS MUST BE MADE PER INSTRUCTIONS IN THE PIONEER 1200 MAINTENANCE AND SERVICE MANUAL.

NOTE

- IF THE VEHICLE IS CONSTANTLY SUBJECTED TO HEAVY USE OR SEVERE OPERATING CONDITIONS, THE PREVENTIVE MAINTENANCE PROCEDURES SHOULD BE PERFORMED MORE OFTEN THAN RECOMMENDED IN THE PERIODIC SERVICE AND LUBRICATION SCHEDULE.
- BOTH THE PERIODIC SERVICE SCHEDULE AND THE PERIODIC LUBRICATION SCHEDULE MUST BE FOLLOWED TO KEEP VEHICLE IN OPTIMUM OPERATING CONDITION.

PERIODIC SERVICE SCHEDULE

REGULAR INTERVAL	SERVICE	
Monthly Service by Owner or Trained Technician	Engine	Check engine oil level. Change as required. See Lubrication Schedule, page 28. Dispose of used oil properly.
		Check engine cooling air intake; visually inspect unshrouded area around engine exhaust for grass and debris, and clean as necessary.
	Tires	Check air pressure and adjust as necessary See Vehicle Capacities Chart on page 29.
	General Vehicle	Wash engine compartment and underside of vehicle. Do not wash engine when hot. Dispose of waste water properly.
Semiannual Service by Trained Technician Only (Every 50 hours of operation).	Battery	Clean terminals and wash dirt from casing. Check electrolyte level. See page 32.
	Front Wheel Alignment and Toe-in	Check and adjust as required. See maintenance and service manual.
	Electrical wiring and connections	Check for tightness and damage.
	Brake System	Inspect master cylinder, wheel cylinders, and brake lines and hoses for damage or leakage.
		Check parking brake cables for damage; replace as required.
		Check brake shoes and drums. Replace if necessary. See Maintenance and Service Manual.
Annual Service by Trained Technician Only (Every 100 hours of operation).	Engine	Check for leaks around gaskets, fill plugs, etc.
		Inspect, clean and regap spark plug; replace if necessary.
Periodic Service Schedule continued on next page...		

PERIODIC SERVICE SCHEDULE		
REGULAR INTERVAL	SERVICE	
Annual Service by Trained Technician Only (Every 100 hours of operation), Continued:	Engine Air Intake System	Check air filter element; clean or replace if necessary. Dispose of used filter element properly.
		Check clamps for tightness; check hose for cracks.
	General Vehicle	Check for loose hardware and tighten as required.
Two year Service by Trained Technician Only (Every 200 hours of operation).	Fuel Filters	Replace. Dispose of used filters properly.

 WARNING
<ul style="list-style-type: none"> IF ANY PROBLEMS ARE FOUND DURING SCHEDULED INSPECTION OR SERVICE, DO NOT OPERATE THE VEHICLE UNTIL REPAIRS ARE MADE. FAILURE TO MAKE NECESSARY REPAIRS COULD RESULT IN FIRE, PROPERTY DAMAGE, SEVERE PERSONAL INJURY, OR DEATH.

PERIODIC LUBRICATION SCHEDULE

PERIODIC LUBRICATION SCHEDULE			
REGULAR INTERVAL	SERVICE	PLACE*	RECOMMENDED LUBRICANT
Semiannually by Owner or Trained Technician (Every 50 hours of operation).	Brake pedal shaft bearings	1.	Dry Moly Lube – Club Car Part No. 1012151
	Accelerator push rod pivots, mounts, and shifter cable pivots	2.	Dry Moly Lube – Club Car Part No. 1012151
	Front Suspension (2 fittings)	3.	Chassis Lube – EP NLGI Grade 2
	Check/add brake fluid	4.	Use ONLY DOT-5 (silicone) Brake Fluid
Annually by Trained Technician Only (Every 100 hours of operation).	Check/fill unitized transaxle to plug level	5.	31 oz. (.92 liter) 80-90 WT. API Class GL-3 or 80-90 WT. AGMA Class EP Gear Lube
	Inspect front wheel bearings (Repack as necessary)	6.	Chassis Lube – EP NLGI Grade 2
First Change 100 Hours – Additional Change (Every 200 Hours of Operation or annually, whichever comes first).	Change engine oil and oil filter	7.	32 oz. (.95 liter) without filter; 38 oz. (1.12 liters) with filter. See Oil Viscosity on page 31.

*See Figure 17, Page 29.

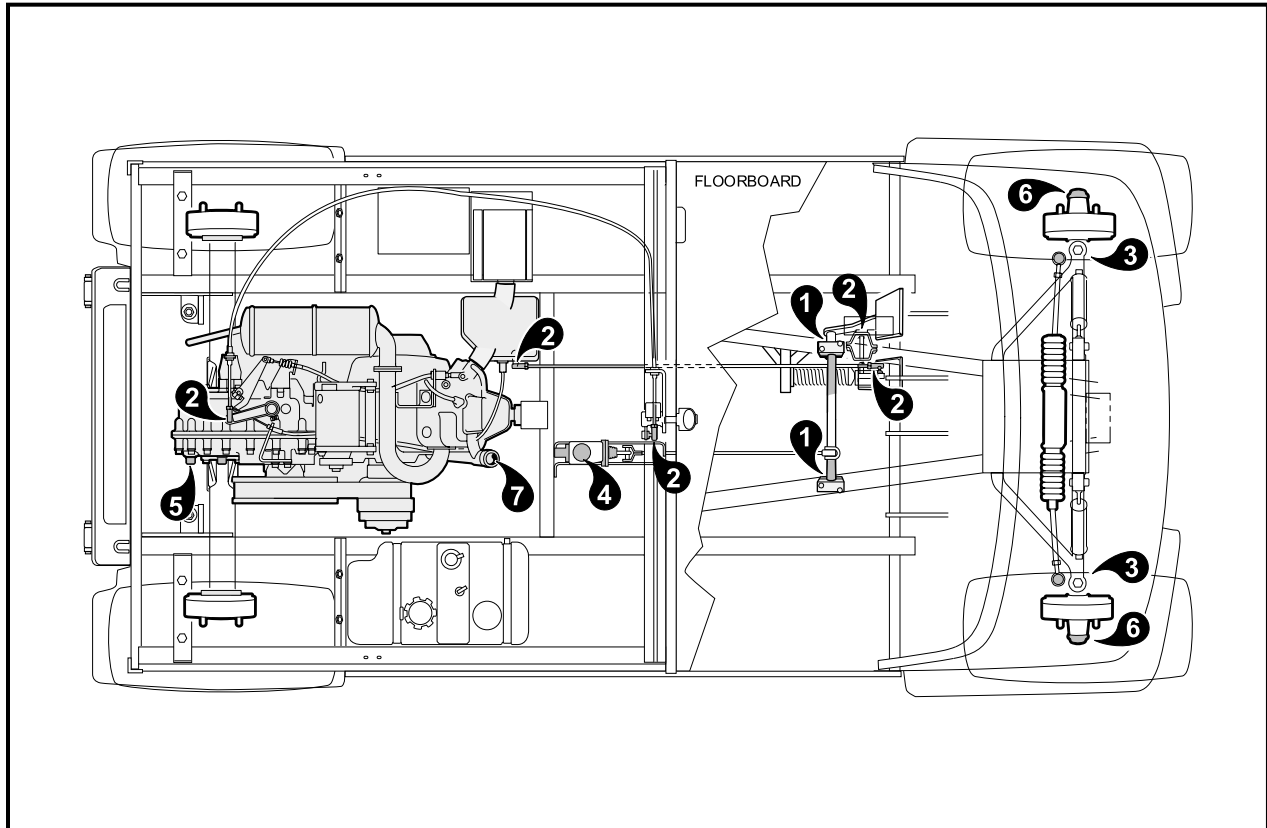

Figure 17 Vehicle Lubrication Points

VEHICLE CAPACITIES

LIQUID CAPACITIES	
COMPONENT	CAPACITY
Engine Crankcase without filter	32 oz. (.95 liters)
Engine Crankcase with filter	38 oz. (1.12 liters)
Unitized Transaxle	31 oz. (.92 liters)
Gasoline Tank	7 gallons (26.5 liters)
Master Cylinder	8 oz. (240 ml)

TIRE CAPACITIES	
TREAD TYPE	TIRE PRESSURE
All-Terrain Tread	Front: 7-11 psi (48-76 kPa) Rear: 14 - 18 psi (97 - 124 kPa)
Turf Tread	Front: 12-16 psi (83-110 kPa) Rear: 16-20 psi (110-138 kPa)

MASTER CYLINDER

The master cylinder is located under the passenger seat toward the center of the vehicle (**Figure 18, Page 30**). Raise or remove the seat to check the brake fluid level.

When checking the brake fluid, also inspect the following:

- The presence of brake fluid on the exterior surface of the master cylinder indicates a leak.
- The vent holes in the reservoir cover should be clean and open.
- The reservoir diaphragm should not have holes or other damage.

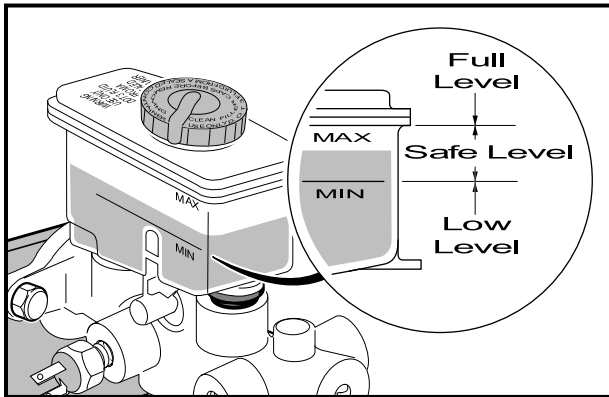

Figure 18 Check Brake Fluid

BRAKE FLUID

Brake fluid level should be within 1/4 inch (6 mm) from top of reservoir (**Figure 18, Page 30**). Also, brake fluid should be clean with no residue in bottom of reservoir or other evidence of contamination.

⚠ CAUTION

- USE ONLY DOT-5 (SILICONE) BRAKE FLUID. USE OF ANY OTHER TYPE BRAKE FLUID IS NOT RECOMMENDED.

ENGINE OIL

Even though the oil warning light on the dash should illuminate if oil level is low, the engine oil level should be checked monthly. The vehicle should be on a level surface when checking oil (**Figure 19, Page 30**). Do not overfill with oil.

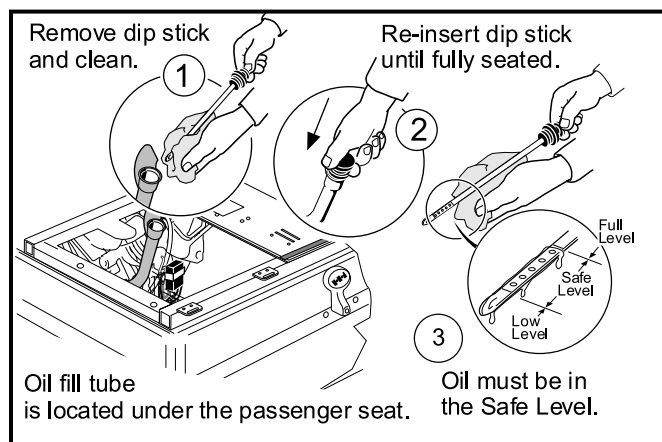

Figure 19 Check Oil Level

OIL VISCOSITY

Choose the viscosity according to the temperature as follows:

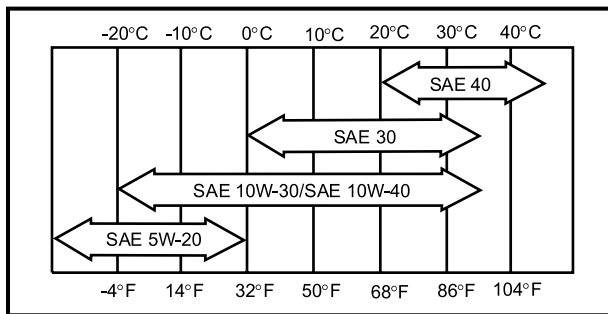

Figure 20 Oil Viscosity Chart

NOTE

- USING MULTI-GRADE OILS (5W-20, 10W-30, AND 10W-40) WILL INCREASE OIL CONSUMPTION. CHECK OIL LEVEL MORE FREQUENTLY WHEN USING THEM.

FUELING INSTRUCTIONS

Read **DANGER** and **WARNING** on page 10.

⚠ DANGER

- TURN KEY SWITCH TO THE *OFF* POSITION BEFORE FUELING.
- NEVER POUR GASOLINE INTO THE FUEL TANK WHEN THE ENGINE IS HOT OR WHILE IT IS RUNNING.
- TO AVOID ELECTRIC ARC CAUSED BY STATIC ELECTRICITY, THE FUEL STORAGE/PUMPING DEVICE MUST BE GROUNDED. IF THE PUMP IS NOT GROUNDED, THE VEHICLE MUST BE GROUNDED TO THE PUMP BEFORE AND DURING THE FUELING OPERATION.
- IF THE VEHICLE HAS AN ALL-WEATHER ENCLOSURE INSTALLED, THE GAS TANK MUST BE PROPERLY VENTED AS SHOWN (FIGURE 21, PAGE 32).
- TO AVOID THE POSSIBILITY OF FIRE, CLEAN UP ANY SPILLED GASOLINE BEFORE OPERATING THE VEHICLE.

⚠ CAUTION

- TO ALLOW FOR EXPANSION, DO NOT FILL HIGHER THAN ONE INCH (2.5 CM) FROM THE TOP OF THE FUEL TANK. AVOID SPILLING FUEL.

NOTE

- WHENEVER POSSIBLE, AVOID USING OXYGENATED FUELS AND FUELS THAT ARE BLENDED WITH ALCOHOL. VEHICLES TO BE STORED FOR EXTENDED PERIODS SHOULD BE PREPARED FOR STORAGE AS INSTRUCTED ON PAGE 23 OF THIS MANUAL.

1. Remove the passenger seat.
2. Remove fuel cap and fill tank with fresh unleaded gasoline only. **See preceding DANGER, CAUTION, and NOTE.**
3. Replace fuel cap on tank. Make sure cap is tightened securely.
4. Replace passenger seat.

⚠ WARNING

- MAKE SURE SEAT HINGES AND LATCH ARE SECURELY ENGAGED BEFORE OPERATING VEHICLE.

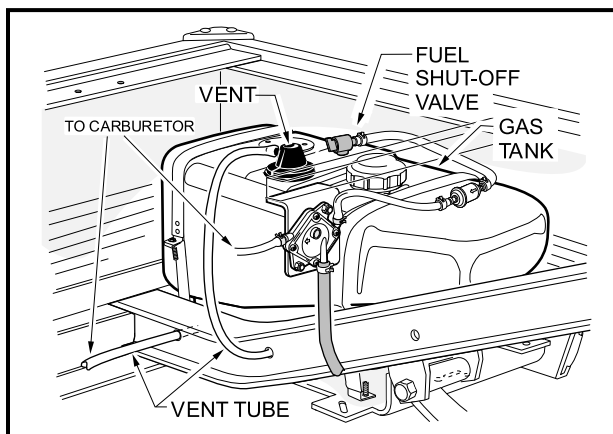

Figure 21 Fuel Tank

BATTERY

Read **DANGER** and **WARNING** on page 10.

⚠ DANGER

- **BATTERY – EXPLOSIVE GASES! DO NOT SMOKE! KEEP SPARKS AND FLAMES AWAY FROM VEHICLE AND SERVICE AREA.**
- **TOOLS, WIRES, AND METAL OBJECTS CAN CAUSE SPARKS WHEN SHORTED ACROSS A BATTERY.**
- **FOLLOW ALL INSTRUCTIONS CAREFULLY WHEN WORKING WITH BATTERIES.**
- **CHARGE BATTERY IN A WELL-VENTILATED AREA ONLY.**
- **POISON! CONTAINS ACID! CAUSES SEVERE BURNS – AVOID CONTACT WITH SKIN, EYES, OR CLOTHING. ANTIDOTES:**
 - **EXTERNAL: FLUSH WITH WATER FOR 15 MINUTES. CALL A PHYSICIAN IMMEDIATELY.**
 - **INTERNAL: DRINK LARGE QUANTITIES OF MILK OR WATER FOLLOWED WITH MILK OF MAGNESIA OR VEGETABLE OIL. CALL A PHYSICIAN IMMEDIATELY.**
 - **EYES: FLUSH WITH WATER FOR 15 MINUTES. CALL A PHYSICIAN IMMEDIATELY.**

⚠ WARNING

- **DO NOT JUMP START THE VEHICLE. TO CHARGE THE BATTERY, USE AN AUTOMOTIVE-TYPE 12-VOLT CHARGER RATED AT 10 AMPS OR LESS.**

The battery in a Club Car gasoline vehicle is a 12-volt, low-maintenance battery that requires infrequent watering (**Figure 22, Page 33**).

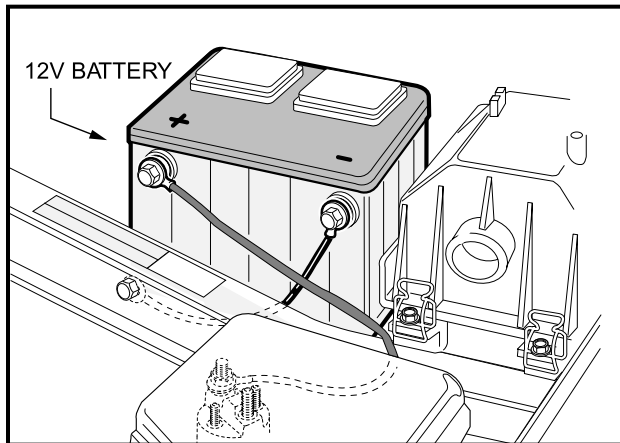

Figure 22 Vehicle Battery

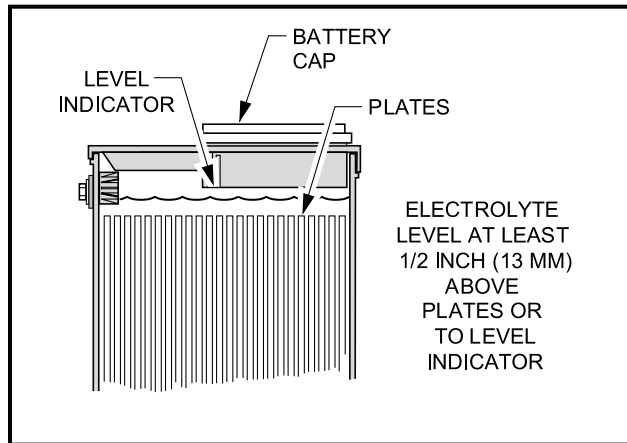

Figure 23 Battery Electrolyte Level

Any corrosion around the positive (+) or negative (–) terminals should be washed off with a solution of baking soda and water (1 cup per gallon of water) and then the baking soda solution rinsed off the battery. Do not allow the solution to get into the battery. Be sure terminals are tight. Let the terminals dry and then spray them with Club Car Battery Terminal Spray (Club Car Part No.1014305). **See following CAUTION.**

⚠ CAUTION

- DO NOT ALLOW BAKING SODA SOLUTION TO ENTER THE BATTERY.
- IF BATTERY WIRE TERMINALS ARE DAMAGED OR CORRODED, REPLACE OR CLEAN THEM AS NECESSARY. FAILURE TO DO SO MAY CAUSE THEM TO OVERHEAT DURING OPERATION.

Be sure battery clamp is properly tightened. Tighten to 12 ft-lb (16.3 N·m). A loose clamp may allow the battery to become damaged from vibration or jarring.

If battery appears weak, have it charged by a trained technician. The battery should never be left discharged any longer than absolutely necessary (do not leave discharged overnight).

CLEANING THE VEHICLE

The vehicle is equipped with an ABS/DR acrylic front body and an all-aluminum rear body and cargo bed. Use a commercially available automotive cleaning solution with a sponge or soft cloth for normal cleaning. A garden hose at normal residential water pressure is adequate. To remove oxidation or discoloration from aluminum, use a commercially available aluminum cleaner paste and fine grade (No. 00) steel wool.

Club Car does not recommend any type of pressure washing or steam cleaning. Such a process will expose electrical components to moisture. Moisture entering electrical components can result in water damage and subsequent component failure.

Use non-abrasive wax products. Battery acid, fertilizers, tars, asphalt, creosote, paint, or chewing gum should be removed immediately to prevent possible stains.

The seats of the vehicle will last longer with proper cleaning. Use a solution of 10% liquid soap and warm water applied with a soft cloth. For imbedded dirt, a soft bristle brush may be used. For heavy soiling, difficult stains, or scratches, blemishes, or other body damage, see Section 4 of the maintenance and service manual. **See following NOTE.**

NOTE

- DISPOSE OF WASTE WATER PROPERLY.

ACCESSORIES

There is a complete line of accessory equipment available from Club Car and our dealers. Care should be taken that these accessories are properly installed by trained technicians, and that they are used in the manner for which they were designed. **See following WARNING.**

⚠ WARNING

- CUSTOM CAB ASSEMBLIES, CANOPY TOPS, WEATHERPROOF ENCLOSURES, AND WINDSHIELDS WILL **NOT** PROTECT OCCUPANTS FROM FLYING OBJECTS.
- IF THE VEHICLE IS EQUIPPED WITH AN ELECTRIC POWERED OR HYDRAULIC LIFT BED, REMOVE THE BED BEFORE SERVICING THE BED LIFT SYSTEM.

ACCESSORIES:

- Light Bar With 2 Halogen Work Lights
- Winch: Rated 1500 lb. (680.4 kg), Remote Operated
- Nerf Bars
- Electric Lift
- Black Canopy Top
- Windshield: One-Piece or Fold Down, Tinted High-Impact Modified Acrylic (Requires Canopy Top)
- 3-Sided Enclosure: Gray or Camouflage (Requires Canopy Top)
- Turf Tires
- Pintle Hitch
- Aluminum Tool Box
- Bed Mat
- Exhaust Spark Arrestor
- Taillights

ELECTRIC WINCH ACCESSORY

If your vehicle is equipped with an electric winch, read and follow all manufacturer safety warnings and instructions in the winch operator manual, as well as the following WARNING and CAUTION statements. Make sure a winch warning decal is affixed to the vehicle on the seat support panel next to the receptacle for the remote operation switch. **See Vehicle Feature Identification, Pages 8 and 9.**

The winch kit available from Club Car includes a remote operation switch which enables the operator to move away from the vehicle and cable. **See following WARNING and CAUTION.**

⚠ WARNING

- BEFORE BEGINNING A WINCH OPERATION:
 - TURN KEY SWITCH **OFF**, PUT FORWARD/REVERSE HANDLE IN **NEUTRAL**, AND ENGAGE THE PARKING BRAKE.
 - DO NOT USE WINCH WHILE PERSONS ARE SEATED ON THE VEHICLE.
 - STAND TO THE SIDE AND AWAY FROM THE VEHICLE TO OPERATE WINCH.

⚠ CAUTION

- USE OF THE WINCH FOR AN EXTENDED PERIOD OF TIME COULD DISCHARGE THE BATTERY. KEEP WINCH OPERATIONS AS SHORT AS POSSIBLE, AND DRIVE THE VEHICLE FOR SEVERAL MINUTES AFTER THE WINCH OPERATION TO RECHARGE THE BATTERY.

SUBSEQUENT OWNER REGISTRATION

In the event a vehicle is bought as a used vehicle from another individual or from a dealer, we strongly urge the new owner to re-register the vehicle with Club Car. This will enable us to contact you if the need arises. Please send your name, address, and serial number(s) of the vehicle(s) to Club Car, Inc., P.O. Box 204658, Augusta, Georgia 30917-4658, ATTN: Vehicle Registration.

VEHICLE SPECIFICATIONS

SPECIFICATIONS	Pioneer 1200
POWER SOURCE	
Engine: 4-cycle, OHV, 351 cc, 11 hp rated, single-cylinder, air cooled, with pressure lubrication system.	•
Fuel System: Side-draft carburetor with float bowl, fixed jets, fuel filters, and impulse fuel pump.	•
Governor: Automatic ground-speed sensing, internally geared in unitized transaxle.	•
Ignition: Transistor electronic ignition with electronic RPM limiter.	•
Unitized Transaxle: Fully synchronized forward and reverse with neutral (15:1 forward, 20.6:1 reverse) with differential lock feature.	•
Electrical System: 12 volt, 500 cca at 0 °F (-17.8 °C), 650 at 32 °F (0 °C). 105-minute reserve capacity and 35-amp charging capacity.	•
Torque Converter: Automatic, variable speed, dry type.	•
STEERING/SUSPENSION/BRAKES	
Steering: Self-adjusting rack and pinion, ackerman.	•
Suspension: Front: Independent A-arms with coil-over shocks. Rear: Semi-independent rear suspension with multi-leaf springs and dual hydraulic shocks.	•
Brakes: Hydraulic brake system – self-adjusting drum brakes on each wheel with separate hand-operated park brake.	•
BODY/CHASSIS	
Frame/Chassis: Twin I-Beam welded aluminum.	•
Side and Rear Body: All aluminum	
Front Body: ABS/DR acrylic molded-in color.	•
Tires: 23 x 10.50 - 12 tubeless, 4 ply rated load range, front and rear.	•
SEATING CAPACITY/FUEL CAPACITY	
Standard Seating Capacity:	2
Fuel Tank: 7 gallons (26.5 liters), unleaded gasoline only.	•
DIMENSIONS/WEIGHT	
Overall Length: Box bed configuration	120 in. (305 cm)
Overall Width	54 in. (137 cm)
Overall Height: At Steering Wheel.	51 in. (130 cm)
Wheelbase	80 in. (203 cm)
Ground Clearance: Under differential: Under foot platform:	6.6 in. (17 cm) 11.4 in. (29 cm)
Front Wheel Tread	43 in. (109 cm)
Rear Wheel Tread	43.5 in. (111 cm)
Specifications continued on next page...	

SPECIFICATIONS	Pioneer 1200
Weight: Standard vehicle (dry): with Turf Tires: with All-Terrain Tires:	1060 lb. (480.8 kg) 1100 lb. (499.0 kg.)
Forward Speed:	17-19 mph (27-31 km/h)
Curb Clearance Circle (diameter):	24 ft. 1 in. (734 cm)
Turning Radius: per SAE J 695	139.6 in. (355 cm)
Intersecting Aisle Clearance:	112.2 in. (285 cm)
Floorboard Height:	17 in. (43 cm)
Load Bed Height:	31.1 in. (79 cm)
Seat Height:	35 in. (89 cm)
Load Bed Size: Box bed inside dimensions:	48.8 x 49.8 x 9.3 in. (124 x 126 x 24 cm)
Load Bed Size: Flat bed dimensions:	46.9 x 48.3 in. (119 x 123 cm)
Vehicle Rated Capacity: Level surface only:	1200 lb. (544 kg)

CLUB CAR[®] LIMITED TWO YEAR WARRANTY FOR 2001 PIONEER VEHICLES

1. WARRANTY:

CLUB CAR, INC., ("CLUB CAR") hereby warrants to the Original Retail Purchaser that its new 2001 Model Pioneer Vehicles purchased from CLUB CAR or an authorized dealer for use in the United States, Canada, Mexico, Puerto Rico and the Caribbean shall be free from defects in material and workmanship under normal use and service for the periods stated below, subject to the provisions, limitations and exclusions contained in this limited warranty.

LIMITED TWO YEAR / 2000 HOUR WARRANTY: The engine assembly, unitized transaxle assembly, main frame assembly, hydraulic dump kit and Custom Cab assembly and doors are warranted with respect to parts and labor against defects in material and workmanship for a period of two years or 2000 hours of operation, whichever first occurs, from the date of purchase.

LIMITED ONE YEAR / 1000 HOUR WARRANTY: All remaining components of the vehicle not specified otherwise and all original equipment options and accessories supplied by CLUB CAR are warranted with respect to parts and labor against defects in material and workmanship for a period of one year or 1000 hours of operation, whichever first occurs, from the date of purchase.

This limited warranty covers material, workmanship and repair labor cost as to those items specifically listed above for the periods specified. Such repair labor shall be performed only by CLUB CAR, its authorized dealers, or a service agency approved by CLUB CAR.

IF THE WARRANTY REGISTRATION FORM IS NOT COMPLETED AND RETURNED TO CLUB CAR AT THE TIME OF THE ORIGINAL RETAIL SALE, PURCHASER MUST PROVIDE PROOF OF DATE OF PURCHASE WITH ANY WARRANTY CLAIM.

2. EXCLUSIONS:

Excluded from any CLUB CAR warranty are all fuses, filters, decals (except safety decals), spark plugs, light bulbs, lubricants, trim pieces, seats, routine wear items such as brake shoes, belts, brushes, bushings, engine mounts, mats and pads, maintenance adjustments, cosmetic deterioration, and items which deteriorate or fail due to exposure or ordinary wear and tear. Also excluded from any CLUB CAR warranty is damage to a vehicle or component resulting from a cause other than a defect including unreasonable or unintended strain or use, improper installation of accessories, installation of parts or accessories that are not original equipment, overloading, accident, alteration, abuse or neglect.

Transportation expenses for warranty services are also excluded from this warranty.

3. VOIDING OF WARRANTY:

THIS AND ANY OTHER WARRANTY SHALL BE VOID IF THE VEHICLE IS ABUSED OR USED IN AN UNINTENDED MANNER OR SHOWS INDICATIONS THAT IT HAS BEEN ALTERED IN ANY WAY, INCLUDING, BUT NOT LIMITED TO, MODIFICATION OF THE SPEED GOVERNOR, BRAKING SYSTEM, STEERING, TRANSAXLE, OR OTHER OPERATING SYSTEMS OF THE VEHICLE TO CAUSE IT TO PERFORM OUTSIDE CLUB CAR SPECIFICATIONS. THE WARRANTY IS LIKEWISE VOID IF THE VEHICLE INVOLVED SHOWS INDICATIONS THAT REASONABLE OR NECESSARY MAINTENANCE AS OUTLINED IN THE OWNER'S MANUAL AND MAINTENANCE AND SERVICE MANUAL WAS NOT PERFORMED AT THE TIME AND IN THE MANNER SPECIFIED IN SUCH MANUALS.

4. SOLE REMEDY:

CLUB CAR's liability under this limited warranty, or in any action whether based upon warranty, contract, negligence, strict product liability or otherwise, shall be the repair or replacement of the vehicle or component thereof that CLUB CAR deems to be defective. Replacement shall mean furnishing, during the applicable limited warranty period, a new vehicle or factory-reconditioned vehicle or component thereof which is identical or reasonably equivalent to the warranted product or component at no cost to the purchaser. Repair shall mean remedying a defect in the vehicle or component thereof at no cost to the purchaser during the applicable limited warranty period. If CLUB CAR elects to repair the vehicle, it may provide factory-reconditioned parts or components. All parts and components replaced under warranty shall become the property of CLUB CAR.

5. HOW TO MAKE A WARRANTY CLAIM:

To make a warranty claim under this limited warranty, you must present the vehicle or defective component to a CLUB CAR authorized PIONEER dealer or send the defective component, freight prepaid, to WARRANTY SERVICES, CLUB CAR, INC., 4125 Washington Road, Evans, Georgia 30809, U.S.A.

6. DISCLAIMER:

THIS LIMITED WARRANTY IS EXCLUSIVE. CLUB CAR MAKES NO OTHER WARRANTY OF ANY KIND, EXPRESSED OR IMPLIED. ANY IMPLIED WARRANTIES OF MERCHANTABILITY OR FITNESS FOR A PARTICULAR PURPOSE WHICH EXCEED THE OBLIGATIONS OR TIME LIMITS STATED IN THIS WARRANTY ARE HEREBY DISCLAIMED BY CLUB CAR AND EXCLUDED FROM THIS WARRANTY. THE PURCHASER AND CLUB CAR EXPRESSLY AGREE THAT THE REMEDY OF THE REPLACEMENT OR REPAIR OF THE DEFECTIVE VEHICLE OR COMPONENT THEREOF IS THE SOLE REMEDY OF THE PURCHASER. CLUB CAR MAKES NO OTHER REPRESENTATION OR WARRANTY OF ANY KIND, AND NO REPRESENTATIVE, EMPLOYEE, OR DEALER OF CLUB CAR HAS THE AUTHORITY TO MAKE OR IMPLY ANY REPRESENTATION, PROMISE OR AGREEMENT WHICH IN ANYWAY VARIES THE TERMS OF THIS WARRANTY.

7. NO CONSEQUENTIAL DAMAGES:

IN NO EVENT SHALL CLUB CAR BE LIABLE FOR ANY INCIDENTAL OR CONSEQUENTIAL DAMAGES INCLUDING, BUT NOT LIMITED TO, LOSS RELATED TO PROPERTY OTHER THAN THE VEHICLE, LOSS OF USE, LOSS OF TIME, INCONVENIENCE, OR ANY OTHER ECONOMIC LOSS.

Some states allow neither limitation on the duration of an implied warranty nor exclusions or limitation of incidental or consequential damages. Therefore, the above limitations or exclusions may not apply to you.

This warranty gives you specific legal rights, and you may also have other rights which vary from state to state.

8. INFORMATION:

For further information contact WARRANTY SERVICES, CLUB CAR, INC., P.O. Box 204658, Augusta, Georgia 30917-4658, U.S.A., or call 706-863-3000.

9. WARNING:

Any modification or alteration of any vehicle beyond factory specifications, including those that affect the weight distribution, stability, or speed of the vehicle, can cause serious personal injury or death.



Club Car, Inc.
P.O. Box 204658
Augusta, GA 30917-4658
USA

Web www.clubcar.com
Phone 1.706.863.3000
1.800.ClubCar
Int'l +1 706.863.3000
Fax 1.706.863.5808