

**Gasoline Vehicles:**

- Carryall 272
- Turf 272
- Carryall 472

# **2005 Owner's Manual**

**Club Car**®



## NOTICE

---

The Transportation and Utility Vehicle Limited Warranty appears on the last pages of this manual. No other warranties, express or implied, are contained herein. Your authorized representative checked the vehicle before it was delivered to you and will provide you a copy of the completed vehicle warranty registration form.

Club Car is not liable for errors in this manual or for incidental or consequential damages that result from the use of the material in this manual.

This manual contains proprietary information that is protected by copyright. All rights are reserved. No part of this manual may be photocopied, reproduced, or translated to another language without the written consent of Club Car, Inc.

The information contained in this document is subject to change without notice.

Club Car reserves the right to make design changes to vehicles without obligation to make these changes on units previously sold.

These vehicles do not conform to Federal Motor Vehicle Safety Standards for automobiles or to FMVSS 500 for low-speed vehicles, and are not equipped for operation on public streets, roads, or highways.



**P. O. Box 204658**  
**Augusta, Georgia 30917-4658 USA**  
**Telephone 706-863-3000**  
**Service Parts Fax 706-855-7413**  
**[www.clubcar.com](http://www.clubcar.com)**

Copyright © 2004 Club Car, Inc.  
*Club Car* is a registered trademark  
of Club Car, Inc.  
This manual effective July 19, 2004.

## FOREWORD

---

Thank you for choosing Club Car, the name most widely recognized as the industry leader in vehicle efficiency and long-lasting value. You have chosen the finest utility vehicle on the market. Please protect your investment and ensure that your Club Car vehicle provides years of reliable, superior performance by reading and following the maintenance instructions in this manual.

Your comfort and safety are important to us, so we urge you to read and follow the step-by-step operating instructions and safety precautions in this manual. These instructions must be followed in order to avoid the risk of severe personal injury. If you rent or loan your vehicle to others, we recommend that you ask them to read this manual before they operate the vehicle.

Club Car products are backed by a customer support system designed to offer you fast, courteous service. In the event that your Club Car vehicle needs repairs or service, we recommend that your local authorized Club Car representative perform them. For the name and address of the Club Car representative nearest you, logon to our web site at [www.clubcar.com](http://www.clubcar.com) or call 1-706-863-3000. If you would prefer to write to us, direct your letter to: Club Car, Attention: Marketing Services, P.O. Box 204658, Augusta, Georgia 30917-4658 USA. Your local authorized Club Car representative can also provide technical advice, parts, and service manuals.

We hope you will consider this owner's manual a permanent part of your Club Car vehicle. If you sell the vehicle, please include the manual so that the next owner will have the important operating, safety, and maintenance information it contains.

## TABLE OF CONTENTS

---

Vehicle Feature Identification – Carryall 272 / Turf 272 .....	4
Vehicle Feature Identification – Carryall 472 .....	6
Safety Details .....	9
General Warnings .....	10
General Information .....	11
Model Identification .....	11
Controls and Indicators .....	11
Seat Latch and Adjustment .....	17
Pre-Operation and Daily Safety Checklist .....	17
Driving Instructions .....	19
Loading and Unloading .....	21
Towing with the Vehicle .....	22
Transporting on a Trailer .....	22
Storage .....	23
Maintenance .....	26
Periodic Service Schedule .....	27
Periodic Lubrication Schedule .....	29
Master Cylinder .....	30
Engine Oil Level Check .....	30
Fueling Instructions .....	32
Battery .....	33
Cleaning the Vehicle .....	34
Accessories .....	34
Subsequent Owner Registration .....	35
Vehicle Specifications .....	35
Wheel and Tire Installation .....	37
Club Car® Limited Two Year Warranty for 2005 Transportation and Utility Vehicles .....	38

# CARRYALL 272 / TURF 272

**⚠ WARNING**

**ROLLOVER OR FALLING OFF MAY CAUSE DEATH**

- Read operators manual and operating instructions.
- Remain seated and hold on to seat handle while moving.
- Drive slowly in turns and straight up and down slopes.
- Do not start vehicle until all occupants are seated.
- Front seats: One (1) person per seat maximum.
- Operate from driver side only and not on public roads.
- Keep entire body inside vehicle while moving.
- Do not operate while under the influence of alcohol or drugs.
- Never attempt jumps.

CCI 102029101

**OPERATING INSTRUCTIONS**

- Read owner's manual and safety warnings located on dash panel prior to driving.
- Study and understand controls.

**TO START ENGINE**

- Place shift lever in - Neutral position.
- Depress brake pedal.
- Turn key switch to "START" position and hold, activating the choke as necessary, until engine starts.

**TO OPERATE VEHICLE**

- Make sure wheels are turned in desired direction.
- Be sure nothing is in your path.
- While vehicle is stopped, select vehicle direction by placing shift lever in desired position.

- Forward    - Neutral    - Reverse (Buzzer will sound)

- Release hand brake.
- Slowly push accelerator pedal to increase speed.
- Engine must be at idle before moving shift lever.

**TO STOP VEHICLE**

- Release accelerator pedal and push brake pedal.
- After stopping, firmly set hand brake.
- Turn key to "OFF" position, remove key and place shift lever in straight up neutral position when not in use.

CCI 102243301

**⚠ WARNING**

**REDUCED STEERING CONTROL MAY CAUSE SERIOUS INJURY OR DEATH**

Disengage differential lock on paved surfaces.

CCI 92046601

**UNDER 16**

**⚠ WARNING**

**YOUNG DRIVERS INCREASE CHANCE OF DEATH**

- Young drivers may not be able to control vehicle.
- No drivers younger than 16 years old.
- Do not leave children unattended on vehicle.

CCI 102044601

**⚠ WARNING**

**Riding in cargo bed can cause severe injury or death. Do not ride in cargo bed.**

CCI 101553901

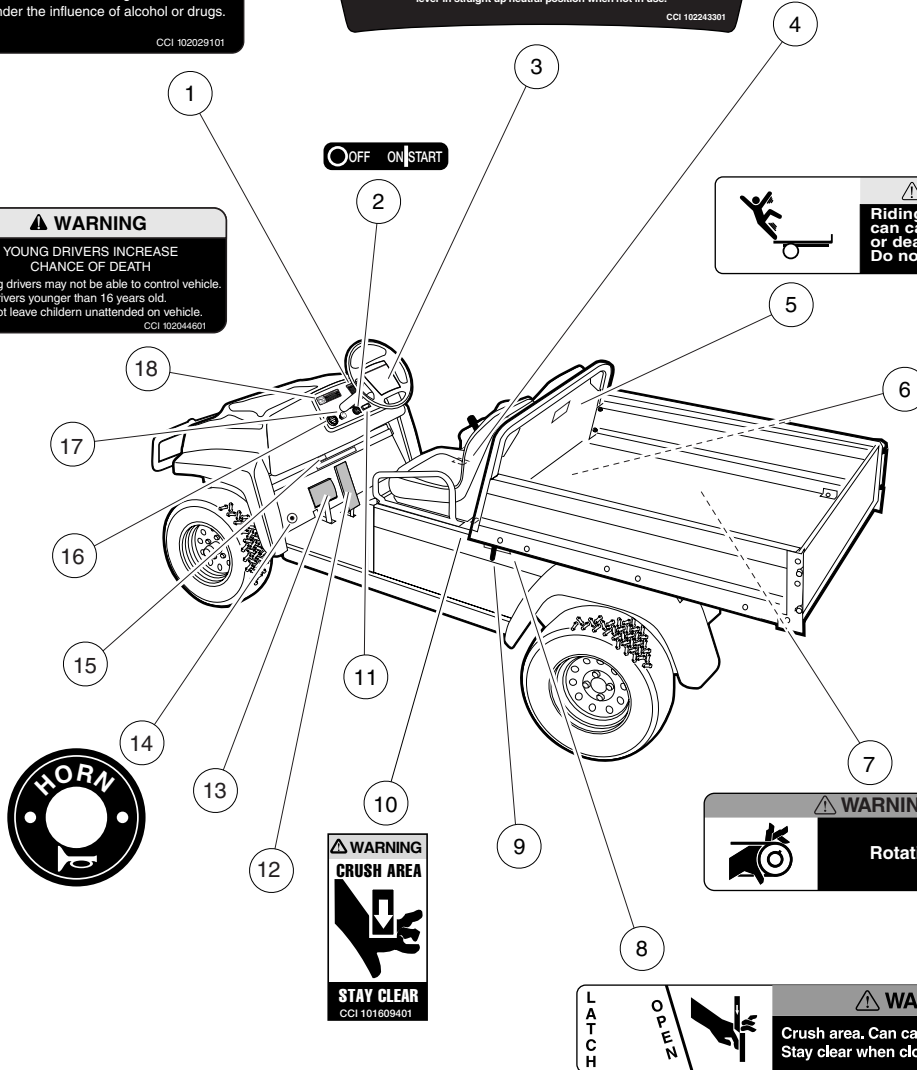

OFF ON/START

**⚠ WARNING**

**CRUSH AREA**

**STAY CLEAR**

CCI 101609401

**⚠ WARNING**

**Rotating Parts**

CCI 102224901

**⚠ WARNING**

**Crush area. Can cause severe injury. Stay clear when closing bed.**

LATCH OPEN

# CARRYALL 272 / TURF 272

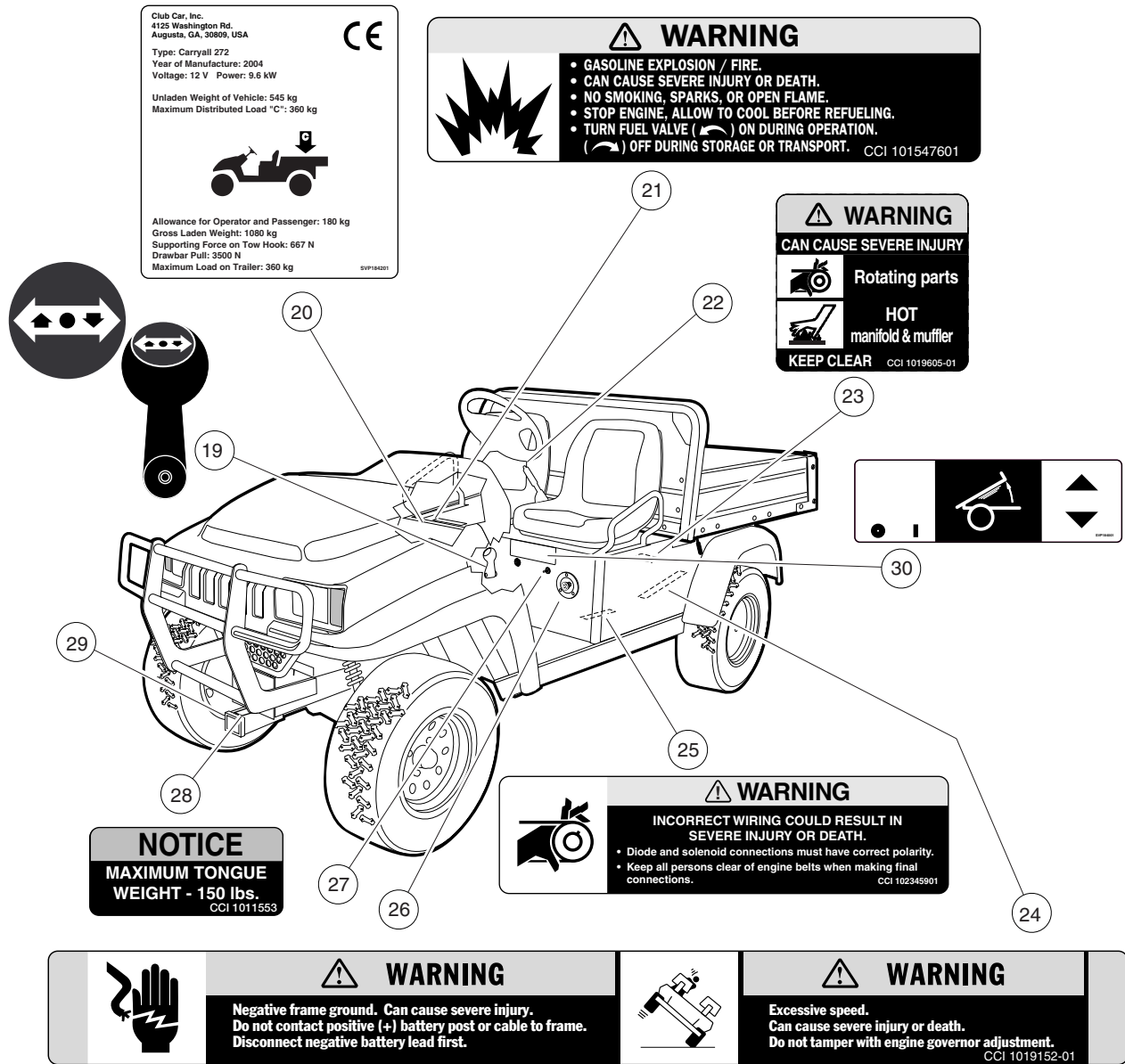

Club Car, Inc.  
4125 Washington Rd.  
Augusta, GA, 30809, USA  
Type: Carryall 272  
Year of Manufacture: 2004  
Voltage: 12 V Power: 9.6 kW

Unladen Weight of Vehicle: 545 kg  
Maximum Distributed Load \*C\*: 360 kg

Allowance for Operator and Passenger: 180 kg  
Gross Laden Weight: 1080 kg  
Supporting Force on Tow Hook: 667 N  
Drawbar Pull: 3500 N  
Maximum Load on Trailer: 360 kg

SVP194201

**WARNING**

**GASOLINE EXPLOSION / FIRE.**  
**CAN CAUSE SEVERE INJURY OR DEATH.**  
**NO SMOKING, SPARKS, OR OPEN FLAME.**  
**STOP ENGINE, ALLOW TO COOL BEFORE REFUELING.**  
**TURN FUEL VALVE ( ) ON DURING OPERATION.**  
**( ) OFF DURING STORAGE OR TRANSPORT.** CCI 101547601

**WARNING**

**CAN CAUSE SEVERE INJURY**

**Rotating parts**

**HOT**  
manifold & muffler

**KEEP CLEAR** CCI 1019605-01

**WARNING**

**INCORRECT WIRING COULD RESULT IN SEVERE INJURY OR DEATH.**

- Diode and solenoid connections must have correct polarity.
- Keep all persons clear of engine belts when making final connections.

CCI 102345901

**NOTICE**

**MAXIMUM TONGUE WEIGHT - 150 lbs.**  
CCI 1011553

	<p><b>WARNING</b></p> <p><b>Negative frame ground. Can cause severe injury. Do not contact positive (+) battery post or cable to frame. Disconnect negative battery lead first.</b></p>		<p><b>WARNING</b></p> <p><b>Excessive speed. Can cause severe injury or death. Do not tamper with engine governor adjustment.</b> CCI 1019152-01</p>
--	---	--	--

## IDENTIFICATION KEY

- |  |   |  |
|--|---|--|
| (1) Driver/Passenger warning decal                         | (13) Brake pedal  | (24) Frame ground and governor warning decal (on frame)    |
| (2) Key switch   | (14) Horn bezel   | (25) Diode wiring decal                                    |
| (3) Operating instructions decal                           | (15) Serial number  | (26) Choke   |
| (4) Differential lock control decal                        | (16) Fuel gauge/hour meter  | (27) Electric bed lift                                     |
| (5) Bed load warning decal                                 | (17) Light switch   | (28) Trailer hitch decal (front and rear receiver hitches) |
| (6) Fuel shut-off valve (on fuel tank)                     | (18) Underage warning decal                                       | (29) Receiver hitch  |
| (7) Rotating parts decal (on top of passenger side fender) | (19) Forward/Reverse handle                                       | (30) Electric bed lift switch decal                        |
| (8) Bed latch decal  | (20) Vehicle information decal                                    |  |
| (9) Bed latch  | (21) Gasoline warning decal (on frame)                            |  |
| (10) Crush area decal                                      | (22) Park brake handle  |  |
| (11) Low oil warning light                                 | (23) Rotating parts and hot manifold decal (on starter/generator) |  |
| (12) Accelerator pedal                                     |   |  |

# CARRYALL 472

**⚠ WARNING**

**ROLLOVER OR FALLING OFF MAY CAUSE DEATH**

- Read operators manual and operating instructions.
- Remain seated and hold on to seat handle while moving.
- Drive slowly in turns and straight up and down slopes.
- Do not start vehicle until all occupants are seated.
- Front seats: One (1) person per seat maximum.
- Operate from driver side only and not on public roads.
- Keep entire body inside vehicle while moving.
- Do not operate while under the influence of alcohol or drugs.
- Never attempt jumps.

CCI 102029101

**OPERATING INSTRUCTIONS**

- Read owner's manual and safety warnings located on dash panel prior to driving.
- Study and understand controls.

**TO START ENGINE**

- Place shift lever in - Neutral position.
- Depress brake pedal.
- Turn key switch to "START" position and hold, activating the choke as necessary, until engine starts.

**TO OPERATE VEHICLE**

- Make sure wheels are turned in desired direction.
- Be sure nothing is in your path.
- While vehicle is stopped, select vehicle direction by placing shift lever in desired position.

- Forward  
 - Neutral  
 - Reverse (Buzzer will sound)

- Release hand brake.
- Slowly push accelerator pedal to increase speed.
- Engine must be at idle before moving shift lever.

**TO STOP VEHICLE**

- Release accelerator pedal and push brake pedal.
- After stopping, firmly set hand brake.
- Turn key to "OFF" position, remove key and place shift lever in straight up neutral position when not in use.

CCI 102243301

**⚠ WARNING**

**REDUCED STEERING CONTROL MAY CAUSE SERIOUS INJURY OR DEATH**

Disengage differential lock on paved surfaces.

CCI 102046601

**⚠ WARNING**

**YOUNG DRIVERS INCREASE CHANCE OF DEATH**

**UNDER 16**

- Young drivers may not be able to control vehicle.
- No drivers younger than 16 years old.
- Do not leave children unattended on vehicle.

CCI 102044601

**⚠ WARNING**

**Rotating Parts**

CCI 10224001

**⚠ WARNING**

**FALLING OFF COULD RESULT IN SEVERE INJURY OR DEATH**

- Remain seated with entire body inside vehicle and hold on to seat handle or handrail at all times.
- Two (2) persons per bench seat maximum.
- One (1) person per bucket seat maximum.
- Do not leave children unattended on vehicle at anytime.
- Never stand in front of or behind vehicle.

CCI 101765791

**⚠ WARNING**

**CRUSH AREA**

**STAY CLEAR**

CCI 101609401

**⚠ WARNING**

**Riding in cargo bed can cause severe injury or death. Do not ride in cargo bed.**

CCI 101533901

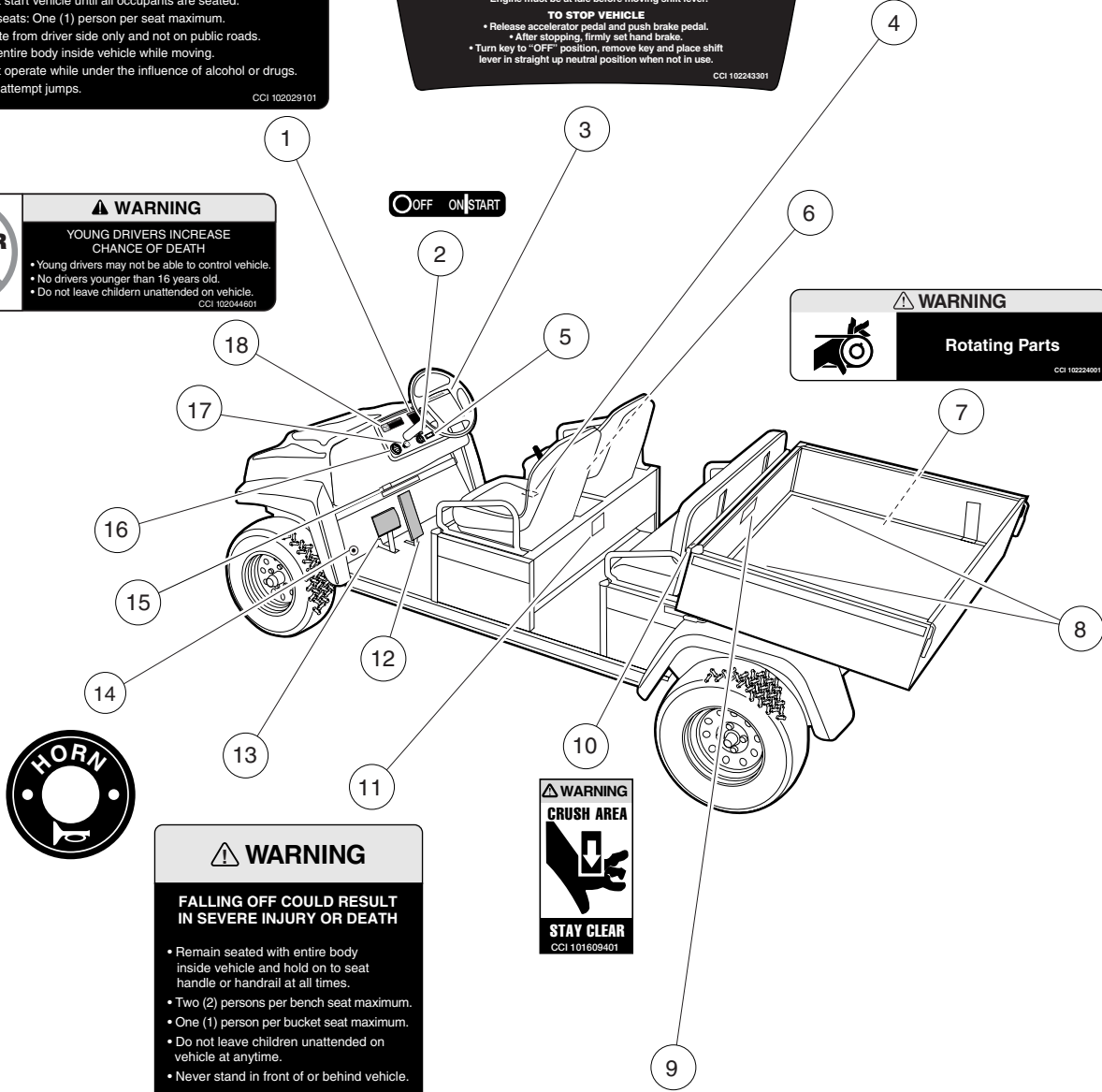



# CARRYALL 472

Club Car, Inc.  
4125 Washington Rd.  
Augusta, GA, 30809, USA

Type: Carryall 472  
Voltage: 12 V Power: 9.6 kW

Unladen Weight of Vehicle: 580 kg  
Maximum Distributed Load "C": 226 kg

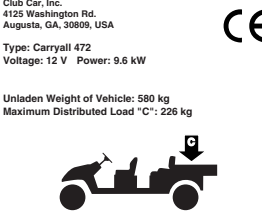

Allowance for Operator and Passenger: 363 kg  
Gross Laden Weight: 1170 kg  
Supporting Force on Tow Hook: 667 N  
Drawbar Pull: 3500 N  
Maximum Load on Trailer: 360 kg

SVP203301

**WARNING**

- GASOLINE EXPLOSION / FIRE.
- CAN CAUSE SEVERE INJURY OR DEATH.
- NO SMOKING, SPARKS, OR OPEN FLAME.
- STOP ENGINE, ALLOW TO COOL, BEFORE REFUELING.
- TURN FUEL VALVE ( ) ON DURING OPERATION.
- TURN FUEL VALVE ( ) OFF DURING STORAGE OR TRANSPORT.

CCI 101547601

**WARNING**

FAILURE TO FOLLOW THESE INSTRUCTIONS CAN CAUSE SEVERE INJURY OR DEATH.

Bed can tip up unexpectedly. Bed hold down bolts must be fastened.

CCI 101707801

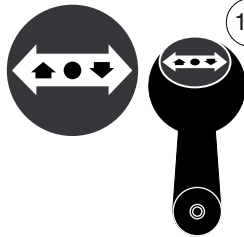

**NOTICE**

MAXIMUM TONGUE WEIGHT - 150 lbs.

CCI 1011553

**WARNING**

INCORRECT WIRING COULD RESULT IN SEVERE INJURY OR DEATH.

- Diode and solenoid connections must have correct polarity.
- Keep all persons clear of engine belts when making final connections.

CCI 102345901

**WARNING**

CAN CAUSE SEVERE INJURY

Rotating parts

HOT manifold & muffler

KEEP CLEAR

CCI 1019405-01

SVP204301

	<b>WARNING</b>		<b>WARNING</b>
	Negative frame ground. Can cause severe injury. Do not contact positive (+) battery post or cable to frame. Disconnect negative battery lead first.		Excessive speed. Can cause severe injury or death. Do not tamper with engine governor adjustment.
	CCI 1019152-01		CCI 1019152-01

## IDENTIFICATION KEY

- |  |                                |   |
|--|--------------------------------|---|
| (1) Driver/passenger warning decal                         | (11) Passenger warning decal   | (21) Gasoline warning decal (on frame)  |
| (2) Key switch   | (12) Accelerator pedal         | (22) Park brake handle  |
| (3) Operating instructions decal                           | (13) Brake pedal               | (23) Bed bolt warning decal   |
| (4) Differential lock control decal                        | (14) Horn bezel                | (24) Rotating parts and hot manifold decal (on starter/generator and heat shield) |
| (5) Low oil warning light                                  | (15) Serial number             | (25) Frame ground and governor warning decal (on frame)                           |
| (6) Fuel shut-off valve (on fuel tank)                     | (16) Fuel gauge/hour meter     | (26) Diode wiring decal   |
| (7) Rotating parts decal (on top of passenger side fender) | (17) Light switch              | (27) Choke  |
| (8) Bed hold down bolts                                    | (18) Underage warning decal    | (28) Trailer hitch decal (on front and rear receiver hitches)                     |
| (9) Bed load warning decal                                 | (19) Forward/Reverse handle    | (29) Receiver hitch   |
| (10) Crush area decal                                      | (20) Vehicle information decal |   |

# Practice Safety



Safety signs like you see above may at first seem shocking, but their impact is mild compared with the reality of severe personal injury.

Your safety and satisfaction are of the utmost importance to Club Car. That is why before operating the vehicle, we urge you to review the information in this manual. Understand and become familiar with the **DANGER**, **WARNING** and **CAUTION** statements and procedures it contains, along with the safety decals that are affixed to your vehicle.

Take time to understand the language of safety. It is a language that can save your life.

## SAFETY DETAILS

### **⚠ WARNING**

- This owner's manual should be read completely before attempting to drive or service the vehicle. Failure to follow the instructions in this manual could result in property damage, severe personal injury, or death.

It is important to note that some vital statements throughout this manual and on the decals affixed to the vehicle are preceded by the words DANGER, WARNING, or CAUTION. For your protection, we recommend that you take special notice of these safety precautions. Safety precautions are essential and must be followed.

If any of the operation or warning decals on the vehicle become damaged, have been removed, or cannot be easily read, they should be replaced immediately to avoid possible property damage, personal injury, or death. Contact your Club Car dealer.

### **⚠ DANGER**

- A DANGER indicates an immediate hazard that will result in severe personal injury or death.

### **⚠ WARNING**

- A WARNING indicates an immediate hazard that could result in severe personal injury or death.

### **⚠ CAUTION**

- A CAUTION with the safety alert symbol indicates hazards or unsafe practices that could result in minor personal injury.

### **CAUTION**

- A CAUTION without the safety alert symbol indicates a situation that potentially could result in property damage.

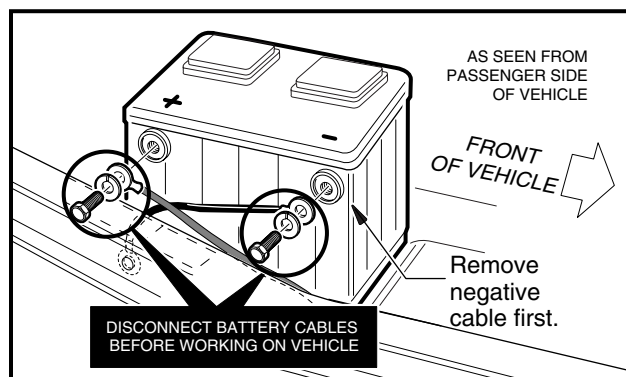

Figure 1 Battery Cable Removal

---

## GENERAL WARNINGS

---

The following safety statement must be heeded whenever the vehicle is being operated, repaired, or serviced. Vehicle feature identification information is also included beginning on page 4. Other specific safety statements appear throughout this manual and on the vehicle.

### **DANGER**

- **Battery – Explosive gases! Do not smoke. Keep sparks and flames away from the vehicle and service area. Ventilate when charging or operating vehicle in an enclosed area. Wear a full face shield and rubber gloves when working on or near batteries.**
- **Gasoline – Flammable! Explosive! Do not smoke. Keep sparks and flames away from the vehicle and service area. Service only in a well-ventilated area.**
- **Do not operate gasoline vehicle in an enclosed area without proper ventilation. The engine produces carbon monoxide, which is an odorless, deadly poison.**
- **A Club Car vehicle will not provide protection from lightning, flying objects, or other storm-related hazards. If caught in a storm while driving a Club Car vehicle, exit the vehicle and seek shelter in accordance with applicable safety guidelines for your location.**

### **WARNING**

- **Follow the procedures exactly as stated in this manual, and heed all DANGER, WARNING, and CAUTION statements in this manual as well as those on the vehicle.**
- **Do not leave children unattended on vehicle.**
- **Prior to leaving the vehicle unattended or servicing the vehicle, set the park brake, place the Forward/Reverse handle in the NEUTRAL position, turn the key switch to the OFF position, and remove the key. Chock the wheels when servicing the vehicle.**
- **Improper use of the vehicle or failure to properly maintain it could result in decreased vehicle performance, severe personal injury, or death.**
- **Any modification or change to the vehicle that affects the stability or handling of the vehicle, or increases maximum vehicle speed beyond factory specifications, could result in severe personal injury or death.**
- **Check the vehicle for proper location of all vehicle safety and operation decals and make sure they are in place and are easy to read.**
- **For vehicles with cargo beds, remove all cargo before raising the bed or servicing the vehicle. If the vehicle is equipped with a prop rod, ensure that it is securely engaged while bed is raised. Do not close bed until all persons are clear of cargo bed area. Keep hands clear of all crush areas. Do not drop cargo bed; lower gently and keep entire body clear. Failure to heed this warning could result in severe personal injury or death.**
- **Only trained technicians should service or repair the vehicle. Anyone doing even simple repairs or service should have knowledge and experience in electrical and mechanical repair. The appropriate instructions must be used when performing maintenance, service, or accessory installation.**
- **To avoid unintentionally starting the vehicle:**
  - **Disconnect battery cables, negative (–) cable first (Figure 1, Page 9).**
  - **Disconnect the spark plug wire from the spark plug.**
- **Frame ground – Do not allow tools or other metal objects to contact frame when disconnecting battery cables or other electrical wiring. Do not allow a positive wire to touch the vehicle frame, engine, or any other metal component.**

- Wear safety glasses or approved eye protection when servicing the vehicle. Wear a full face shield and rubber gloves when working on or near batteries.
- Do not wear loose clothing or jewelry such as rings, watches, chains, etc., when servicing the vehicle.
- Use insulated tools when working near batteries or electrical connections. Use extreme caution to avoid shorting of components or wiring.

## GENERAL INFORMATION

Throughout this manual, important vehicle information and features are highlighted. We urge the owner/operator to read and understand this manual.

## MODEL IDENTIFICATION

The serial number of each vehicle is printed on a bar code decal mounted on the frame directly above the accelerator pedal (Example: AD0501-583947) (**Figure 2**). There is also a second serial number decal mounted on the front body frame behind the instrument panel. The instrument panel must be removed to view this decal. **See following NOTE.**

**NOTE:** Have the vehicle serial number available when ordering parts or making inquiries.

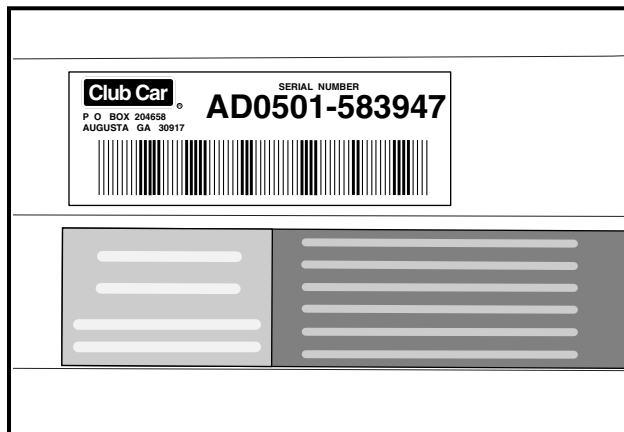

Figure 2 Serial Number

## CONTROLS AND INDICATORS

See General Warnings on page 10.

### **⚠ WARNING**

- Before allowing anyone to drive the vehicle, make sure the driver is familiar with all controls and operating procedures.

WARNING CONTINUED ON NEXT PAGE...

## **⚠ WARNING**

- Do not tamper with the governor. Doing so will void the warranty, as well as damage the engine and other components, and could result in property damage, personal injury, or death due to unsafe speeds.
- Do not shift the Forward/Reverse handle while the vehicle is in motion.
- Engine must be at idle before shifting the Forward/Reverse handle. Failure to do so may result in injury to inattentive passengers and (or) damage to the vehicle.
- To avoid unintentionally starting or rolling the vehicle, set the park brake, place the Forward/Reverse handle in the NEUTRAL position, turn the key switch to the OFF position, and remove the key when leaving the vehicle.
- With the differential lock engaged, vehicle turning functions are greatly reduced. To prevent loss of vehicle control when differential lock is engaged, do not operate vehicle at speeds greater than half throttle and use caution when attempting to turn the vehicle.

## **KEY SWITCH**

The key switch is mounted on the instrument panel to the right of the steering column (**Figure 3**). It has three positions: OFF, ON, and START. To start the vehicle, place the Forward/Reverse handle in the NEUTRAL position and turn the key past the ON position to the START position and hold until the engine is running smoothly. Release the key and it will return to the ON position and the engine should idle. The engine will continue to idle until the key is turned to the OFF position. **See following WARNING, CAUTION and NOTE.**

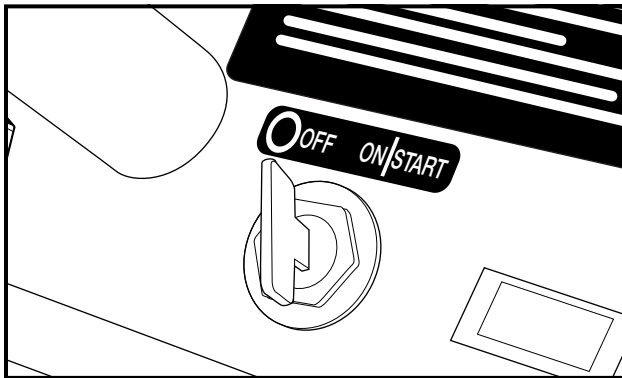

Figure 3 Key Switch

## **⚠ WARNING**

- Moving parts! Keep clear of the engine compartment while the engine is running.

## **CAUTION**

- Do not “rev” the engine for long periods of time while the Forward/Reverse handle is in the NEUTRAL position. Failure to heed this caution could result in damage to the unitized transaxle.
- Do not shift the Forward/Reverse handle while the accelerator pedal is pressed. Shift the handle only when the vehicle is at a complete stop and the engine is at idle. Failure to heed this caution could result in damage to the unitized transaxle.

**NOTE:** The key can be removed only when the key switch is in the OFF position.

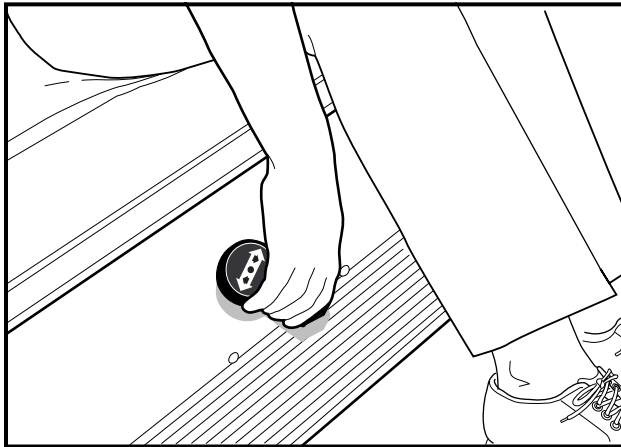

Figure 4 Forward/Reverse Handle

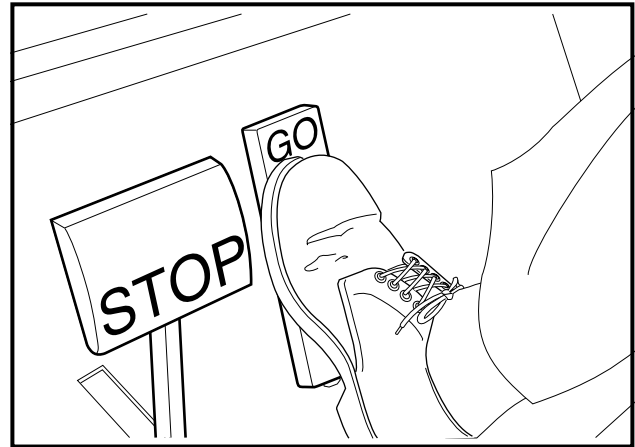

Figure 5 Accelerator and Brake Pedals

## FORWARD/REVERSE CONTROL

The Forward/Reverse handle is located on the seat support panel (**Figure 4**). The handle has three distinct positions: ▲ (FORWARD), ● (NEUTRAL), and ▼ (REVERSE). Rotate the handle towards the driver (FORWARD) to operate the vehicle in the forward direction, or towards the passenger (REVERSE) to operate the vehicle in reverse. The engine can be started only when the handle is in the straight up position (NEUTRAL). The engine must be at idle before shifting the Forward/Reverse handle. **See WARNING and CAUTION on page 12.**

The vehicle operates at a reduced speed in reverse. The reverse buzzer will sound as a warning when the Forward/Reverse handle is in the REVERSE position.

## ACCELERATOR PEDAL

The accelerator pedal is the pedal on the right, with the word GO molded into it (**Figure 5**).

With the engine running and the Forward/Reverse handle in the FORWARD or REVERSE position, vehicle speed will increase as the accelerator pedal is pressed. When the accelerator pedal is released, it will return to the original position and the engine will idle. **See WARNING and CAUTION on page 12.**

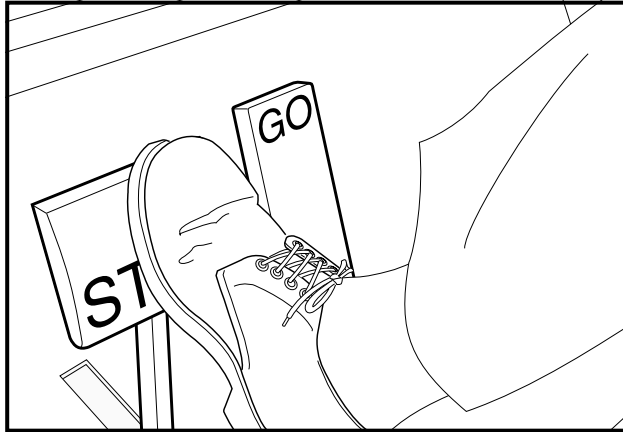

Figure 6 Brake Pedal

## BRAKE PEDAL

The brake pedal is the large pedal on the left with the word STOP molded into it (Figure 5). To slow or stop the vehicle, press the brake pedal (Figure 6).

## PARK BRAKE

The park brake handle is located between the driver and passenger seats. To engage the park brake, first apply pressure to the brake pedal, and then pull up on the park brake handle until handle latches into place. To disengage, pull up on the handle and press the button on the end of the handle. Push handle down. **See following WARNING.**

### **⚠ WARNING**

- The park brake has multiple locking positions and should be firmly locked to prevent the vehicle from rolling.

## CHOKE

The choke (1) is located on the seat support panel, below and to the left of the driver's left knee. If the vehicle is hard to start in cool or cold temperatures, activate choke: Pull the choke handle out to activate. Release the handle when the engine begins to run smoothly (Figure 7).

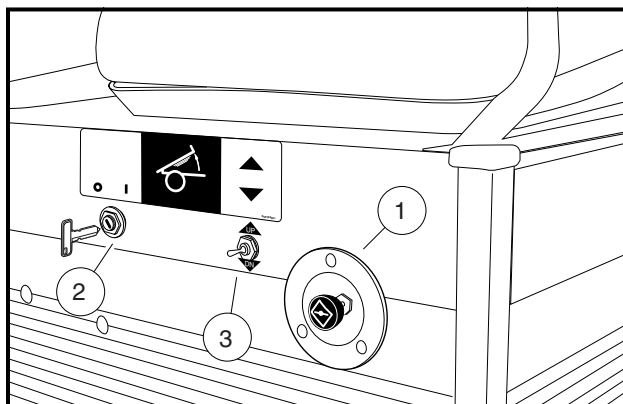

Figure 7 Choke and Electric Bed Lift



Figure 8 Differential Lock



## ELECTRIC BED LIFT – 272 VEHICLES

The electric bed lift switch is located on the seat support panel, to the left of the choke (**Figure 7**). The bed lift is equipped with a key switch that locks the lift switch, minimizing unauthorized access to moving parts of the engine compartment.

To lift the bed, insert the lift switch key (2), and turn it to the on ( I ) position. Pull up and hold the toggle switch (3) in the up (UP) (▲) position. Release switch to stop lifting operation. To close the bed, press down and hold switch in the down (DN) (▼) position. The bed lift will make a loud clicking sound to signal the bed is in the rest position. Turn the lift switch key to the locked ( O ) position and remove key. **See following WARNING.**

## MANUAL BED LIFT AND PROP ROD– 472 VEHICLES

To lift the bed on the 472 vehicle, remove the two bolts, four washers, and two nuts that secure the bed to the vehicle frame. Lift cargo bed and remove the prop rod from the clip (1) and insert it into the hole (2) in the inner body (**Figure 9**). **See following DANGER.**

### **⚠ DANGER**

- **Use caution when working under bed. Be sure prop rod is secure. Otherwise the bed will fall, resulting in severe personal injury or death.**

To close the bed, secure the prop rod in the prop rod clip and lower the bed gently. **DO NOT** drop the bed. **See following WARNING.**

Install bolts, flat washers, and locknuts through the bed frame and the vehicle frame on both sides of the vehicle. Tighten to 75 in-lb (8 N·m).

### **⚠ WARNING**

- **Keep clear of moving parts when bed is in the raised position and the engine is running**
- **For vehicles with cargo beds, remove all cargo before raising the bed or servicing the vehicle. If the vehicle is equipped with a prop rod, ensure that it is securely engaged. Do not close bed until all persons are clear of cargo bed area. Keep hands clear of all crush areas. Do not drop cargo bed; lower gently and keep entire body clear. Failure to heed this warning could result in severe personal injury or death.**

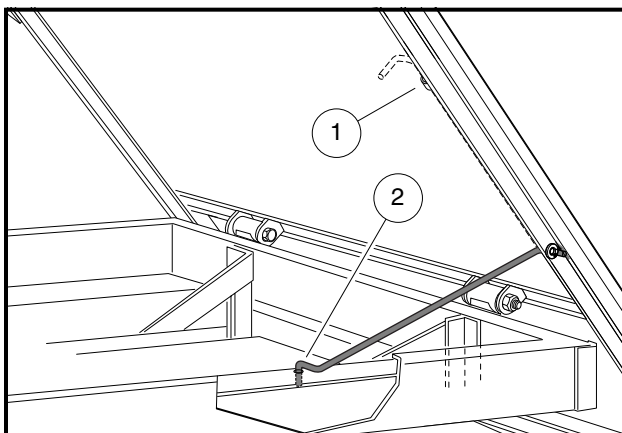

**Figure 9 Prop Rod – 472 Vehicle**

## DIFFERENTIAL LOCK

### **⚠ WARNING**

- With the differential lock engaged, vehicle turning functions are greatly reduced. To prevent loss of vehicle control when differential lock is engaged, do not operate vehicle at speeds greater than half throttle and use caution when attempting to turn the vehicle.
- Disengage differential lock on paved surfaces.

The differential lock is used to provide better traction at the rear wheels when necessary. Engaging the differential lock will transfer power to both rear wheels simultaneously (**Figure 8**).

1. To engage the differential lock, slow the vehicle to no more than half throttle and pull differential lock handle toward the back of the vehicle. The differential lock will engage when power to both rear wheels is required.
2. To disengage the differential lock, come to a complete stop, then push lever toward front of vehicle.

## LOW OIL WARNING LIGHT

The vehicle is equipped with a low oil warning light, located on the instrument panel just to the right of the steering column and key switch (**Figure 10**). If the warning light comes on, oil should be checked and added to the engine as necessary before continuing to use the vehicle. The vehicle should never be driven when the low oil warning light remains on. If the warning light goes on and off, the vehicle may be driven, but oil should be added at the first opportunity. If the oil level is correct and the warning light stays on, have a trained technician check the vehicle. **See following CAUTION.**

### **CAUTION**

- Failure to add oil immediately when the low oil warning light stays on may result in permanent engine damage.

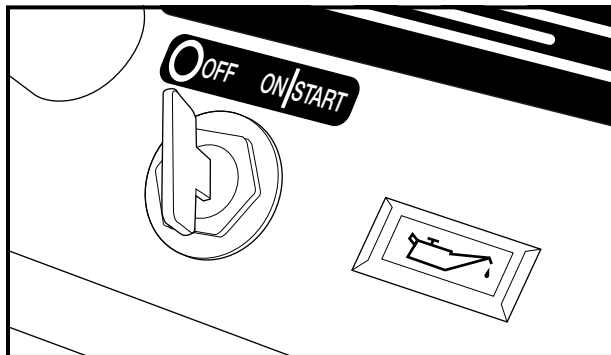

Figure 10 Low Oil Warning Light

## FUEL GAUGE/HOUR METER

The vehicle is equipped with a fuel gauge and hour meter housed together at the lower left corner of the instrument panel. The fuel gauge operates when the key switch is in the ON position, and allows the operator to monitor the fuel level in the vehicle. The hour meter operates only when the engine is running, and should be used by the trained technician to track vehicle usage and determine when periodic service procedures are required. **See Periodic Service Schedule on page 27.**

## HEADLIGHT CONTROL

The headlight control is located on the instrument panel between the fuel gauge/hour meter and steering column. Pull the headlight control knob out to turn the headlights on and push the knob in to turn the headlights off.

**NOTE:** Using the headlights for extended periods of time without the engine running, or with the engine idling, will discharge the battery.

## SEAT LATCH AND ADJUSTMENT

---

- **Carryall 272 / Turf 272:**

The seats are hinged to allow easy access to the engine compartment. A latch at the rear of each seat bottom keeps the seat from moving on its hinges while the vehicle is in operation. To disengage the latch, grasp the seat back and pull firmly in a forward/upward direction until the latch releases. To engage the seat latch, push down firmly on the seat back until the seat locks into place. **See following WARNING.**

- **Carryall 472:**

The front seats are hinged to allow easy access to the fuel tank and master cylinder. A latch at the rear of each seat bottom keeps the seat from moving on its hinges while the vehicle is in operation. To disengage the latch, grasp the seat back and pull firmly in a forward/upward direction until the latch releases. To engage the seat latch, push down firmly on the seat back until the seat locks into place. The rear bench seat has a removable bottom cushion, which allows for access to the battery and engine oil check. To remove the bottom cushion, locate the pull tab at the center of the back edge and pull forward and up. When replacing the cushion, set the plastic strip on the underside front edge immediately behind the frame front edge, and gently push the back edge of the cushion down into position. **See following WARNING.**

## PRE-OPERATION AND DAILY SAFETY CHECKLIST

---

Each Club Car vehicle is thoroughly inspected and adjusted at the factory; however, upon receiving your new vehicle(s), you should become familiar with its controls, indicators, and operation. Carefully inspect the vehicle to be satisfied that it is in proper working condition before accepting delivery.

Use the following checklist as a guide to inspect your new vehicle. This checklist should also be used daily to ensure vehicle is in proper working condition and in conjunction with the Periodic Service Schedule on page 27. Any problems should be corrected by your Club Car distributor/dealer or a trained technician.

- **General:** All the parts should be in place and properly installed. Be sure that all nuts, bolts, and screws are tight. Check hose clamps for tight fit and the starter belt for tightness.
- **Safety and information decals:** Check to ensure that all safety and information decals are in place. **See pages 4 and 5.**
- **Tires:** Check for proper tire pressure. Visually inspect tires for wear, damage, and proper inflation on a daily basis. **See Vehicle Specifications on page 35.**
- **Battery:** Before using vehicle for the first time, check electrolyte to ensure it is at the proper level (**Figure 22, Page 33**). Check battery posts. Wires should be tight and free of corrosion and battery should be fully charged. Check that terminal covers are in place and in good condition.
- **Engine:** Check for proper engine oil level. **See Engine Oil Level Check on page 30.**

- **Fuel:** Check fuel level. **See Fueling Instructions on page 32.** Check fuel tank, lines, cap, pump, fuel filters, and carburetor for fuel leakage on a daily basis.
- **Exhaust system:** Check for leaks.
- **Hydraulic brakes:** Check fluid level. **See Master Cylinder on page 30.**

## PERFORMANCE INSPECTION

After you have familiarized yourself with the vehicle's controls and have read and understood the driving instructions, take the vehicle for a test drive.

Use the following checklist as a guide to inspect your new vehicle and check daily for proper operation. Any problems should be corrected by a Club Car dealer or a trained technician.

- **Forward/Reverse shifter:** Check for proper operation. **See Controls and Indicators on page 11.**
- **Brakes:** Be sure the brakes function properly. When brake pedal is fully pressed under moderate pressure, it should not go more than halfway to the floor, and vehicle should come to a smooth, straight stop. If the brake pedal goes more than halfway to the floor, or if the vehicle swerves or fails to stop, have the brake system checked and adjusted as required. When brake pedal is fully pressed under heavy pressure, pedal should feel firm and foot pad should be a minimum of 2 inches (5.1 cm) from floor. Brake adjustment must be maintained so the brake pedal cannot be pressed to the floor under any circumstance.
- **Park brake:** Apply moderate pressure to park brake handle. Tension should increase as the handle is pulled. When latched, the park brake should lock the wheels and hold the vehicle stationary (on an incline of 20% or less).
- **Reverse buzzer:** The reverse buzzer should sound as a warning when the Forward/Reverse handle is in the REVERSE position.
- **Steering:** The vehicle should be easy to steer and should not have any play in the steering wheel.
- **Accelerator:** After starting the engine with the key switch and placing the Forward/Reverse handle in the FORWARD position, the vehicle should accelerate smoothly to full speed as the accelerator pedal is pressed. When the pedal is released it should return to the original position and the engine should idle. Vehicles operate at reduced speed in reverse.
- **Governor:** Check maximum vehicle speed. It should operate at 17-19 mph (27-31 km/h) on a level surface.
- **Differential lock cable:** With the wheels at rest, pull the differential lock handle toward the rear of the vehicle (locked position). The differential lock arm at the other end of the cable should move approximately one-half inch (12.7 mm) downward. When the differential lock handle is placed back into the unlocked position, the differential lock arm should move approximately one-half inch (12.7 mm) upward.
- **General:** Listen for any unusual noises such as squeaks or rattles. Check the vehicle's ride and performance. Have a Club Car dealer or a trained technician investigate anything unusual.

---

## DRIVING INSTRUCTIONS

---

### **▲ WARNING**

- Only licensed drivers should be allowed to drive this vehicle.
- Before allowing anyone to drive the vehicle, make sure the driver is familiar with all controls and operating procedures.
- No one under the age of 16 years should be allowed to drive the vehicle.
- No more than one person per seat at one time.
- Do not allow riders in the cargo bed.
- For night use, the vehicle must be equipped with headlights, taillights, and reflectors.
- The vehicle is not specially equipped for handicapped persons:
  - Be sure all passengers are capable of securing themselves in a moving vehicle before allowing them to ride in one.
  - Be sure all persons can properly operate the vehicle prior to allowing them to drive the vehicle.
- Stop the vehicle before shifting the Forward/Reverse handle. Engine must be at idle before shifting the Forward/Reverse handle. Failure to do so may result in injury to inattentive passengers and (or) damage to the vehicle.
- To help avoid being struck, do not stand in front of or behind the vehicle.
- Do not leave children unattended on vehicle.
- Operate the vehicle from the driver seat only.
- To help prevent falls from the vehicle, remain seated and hold on to seat handles at all times. Driver should keep both hands on the steering wheel when the vehicle is in motion.
- To help prevent the possibility of serious injury, keep entire body inside the vehicle.
- To help prevent overturning the vehicle, drive slowly in turns.
- To help prevent overturning the vehicle, drive slowly straight up and down slopes. Avoid driving the vehicle on slopes exceeding 20% incline.
- Avoid stopping a loaded vehicle on a hill. If a loaded vehicle must be stopped on a hill, avoid sudden starts or rolling backwards and stopping suddenly. Failure to heed this warning could result in overturning the vehicle.
- To help avoid possible injury to inattentive passengers and (or) damage to the vehicle, avoid sudden starts, sudden stops, and abrupt turns.
- To help avoid the possibility of losing control of or overturning the vehicle, reduce speed for adverse driving conditions such as wet grass or rough terrain.
- Do not use the vehicle on public roads. It is neither designed nor intended for street use and should not be licensed for use on public roads.
- The vehicle should be driven only in specified areas by trained drivers.
- Do not drive while under the influence of alcohol, drugs, or medications.
- Use brakes to reduce speed when coasting downhill.
- Never attempt jumps.

No one should drive the vehicle without first being instructed in the proper operation and use of vehicle controls. An experienced operator should accompany each first-time driver on a test drive before allowing the driver to operate the vehicle alone.

To ensure safe operation of the vehicle, follow exactly and in order, all of the following procedures. Read and understand all instructions prior to driving the vehicle.

## STARTING THE VEHICLE

1. Read safety warnings on instrument panel and vehicle loading information located above pedals.
2. Be sure load, if any, is secure.
3. Study and understand controls.
4. Be sure passenger is seated and holding on to hand hold. Driver should have both hands on the steering wheel.
5. Make sure wheels are turned in desired direction and nothing is in your path.
6. Make sure the Forward/Reverse handle is in the NEUTRAL position.
7. Press and hold the brake pedal.
8. Turn the key all the way to the START position and hold, activating the choke as necessary, until the engine is running smoothly. The engine will idle in neutral.
9. Release hand brake.
10. While keeping the brake pedal engaged, select direction of travel by placing shift handle in desired position (F = forward or R = reverse). Engine must be at idle before moving shift handle. A buzzer will sound as a warning when the Forward/Reverse handle is in the REVERSE position.
11. Release the brake pedal completely, and then slowly press the accelerator pedal. As the accelerator pedal is pressed, the vehicle will begin to move, and speed will increase until full speed is reached. **See following WARNING.**

### **WARNING**

- **Operator must control vehicle speed when going downhill.**
- **Never shift the vehicle out of the FORWARD position while going downhill. If you do, you will not be able to shift into the REVERSE position or back into the FORWARD position until stopped.**
- **Press the brake pedal as necessary and press the accelerator pedal partially when descending a hill. With the accelerator pedal partially pressed, the governor will cause the engine to assist the brakes in controlling downhill speed.**

## STOPPING THE VEHICLE

To stop the vehicle, release the accelerator pedal and press the brake pedal until the vehicle comes to a complete stop. **See following WARNING and CAUTION.**

### **WARNING**

- **Driving through water may affect the brakes. After driving through water, check effectiveness of the brakes by gently pressing the brake pedal. If the vehicle does not slow down at the normal rate, continue to press the brake pedal until the brakes dry out and normal performance returns.**

### **CAUTION**

- **When stopped on a hill, use the brake pedal to hold your position. Do not use the accelerator pedal.**

## PARKING AND LEAVING THE VEHICLE

1. After stopping the vehicle, set hand brake until it locks. Make sure it is fully engaged. This will prevent the vehicle from rolling.
2. Turn the key switch to the OFF position and place the Forward/Reverse handle in the NEUTRAL position. Remove the key and turn the fuel shut-off valve to the closed (OFF) position when the vehicle is not in use (Figure 11, Page 24). See also Figure 19, Page 32 or Figure 20, Page 32.

## LOADING AND UNLOADING

### **▲ WARNING**

- Firmly engage the park brake before loading the vehicle.
- Do not allow riders in the cargo bed.
- Reduce vehicle load and speed when driving up or down slopes or on uneven terrain.
- Do not exceed the rated vehicle capacity. Rated capacity is for level surfaces only.
- Overloading can affect vehicle handling or cause component failure, resulting in loss of control of vehicle and possible severe personal injury.
- Reduce speed and avoid sudden stops when backing up. Failure to do so may cause the vehicle to overturn or flip over backwards.
- Avoid stopping on a hill when loaded. If you must stop on a hill, avoid sudden starts, or rolling backwards and stopping suddenly. Failure to heed this warning may cause vehicle to overturn, possibly resulting in severe personal injury.
- Vehicle load and speed must be reduced when driving up or down slopes or on uneven terrain.
- Do not load the tailgate. The tailgate should be in the upright position and latched securely while the vehicle is in motion.
- To help avoid shifting the vehicle load and possibly overturning the vehicle, avoid sudden starts, sudden stops, and abrupt turns. Make sure cargo is well secured.
- The cargo's center of gravity may affect the handling, steering, and braking of the vehicle. When the vehicle is loaded, reduce speed and drive slowly in turns.
- Avoid top-heavy loads. The center of gravity of a load should never exceed 15 inches (38 cm) above the bottom of the cargo bed.
- Unload cargo bed before raising vehicle with a lift, hoist, or jack.

Center and secure cargo as far forward as possible in the cargo bed. Do not overload the vehicle. **See the following chart for vehicle capacities.**

	<b>272</b>	<b>472</b>
<b>Maximum payload capacity</b> (Cargo bed load plus gross trailer weight)	800 lb. (363 kg)	500 lb. (227 kg)
<b>Maximum vehicle capacity</b> (Cargo load, passengers, plus gross trailer weight)	1200 lb. (545 kg)	1300 lb. (590 kg)
<b>Maximum gross vehicle weight</b> (Fully loaded vehicle, including accessories)	2350 lb. (1080 kg)	2500 lb. (1134 kg)
<b>Maximum passenger capacity</b> (Operator and passenger)	400 lb. (181 kg)	800 lb. (363 kg)
<b>Trailer tongue weight</b>	150 lb. force (667 N)	150 lb. force (667 N)

Maximum payload capacity must be reduced accordingly when any option or accessory is installed on the vehicle. **See following NOTE.**

**NOTE:** A standard 272 vehicle with a cab accessory weighing 235 lb. (107 kg) must reduce its maximum payload capacity by 235 lb. (107 kg) to 565 lb. (256 kg).

---

## TOWING WITH THE VEHICLE

---

### **WARNING**

- Never tow a vehicle or trailer on public streets or highways.
- Normal vehicle operating speed should be reduced when towing.
- Extreme caution should be used when towing.
- Do not allow riders in the vehicle or trailer being towed.
- Total vehicle capacity, including the vehicle load rating and the gross weight of the vehicle or trailer being towed, should not exceed the weight previously specified.
- Avoid sudden starts, sudden stops, and tight turns when towing.
- Avoid stopping on a hill when towing. If you must stop on a hill, avoid sudden starts, or rolling backwards and stopping suddenly. Failure to heed this warning could cause vehicle to overturn, possibly resulting in severe personal injury.

Towing another vehicle or a trailer can have adverse effects on vehicle handling, be especially cautious when towing other equipment with a vehicle. **See the preceding chart for vehicle capacities.**

Parking the vehicle with a trailer on a hill should be avoided. If you must park on a hill, apply brakes and have someone chock tires of trailer. Brakes should be released to allow chocks to absorb load of trailer. After tires have been chocked, engage park brake.

---

## TRANSPORTING ON A TRAILER

---

### **WARNING**

- Turn the fuel shut-off valve to the closed (OFF) position (Figure 11, Page 24).
- Do not allow riders in the trailer being towed.
- Avoid sudden starts, sudden stops, and tight turns when towing.
- Avoid stopping on a hill when towing. If you must stop on a hill, avoid sudden starts, or rolling backwards and stopping suddenly. Failure to heed this warning could cause the vehicle to overturn, possibly resulting in severe personal injury.
- Reduce normal driving speed when transporting a vehicle on a trailer.
- For use on public roads, the trailer must meet all federal, state, and local requirements such as taillights, brake lights, etc.
- Never tow a vehicle behind a passenger vehicle or truck on a public road unless it is on an approved trailer.

WARNING CONTINUED ON NEXT PAGE...



---

**⚠ WARNING**

- The vehicle to be transported should be tied securely to the trailer, with the Forward/Reverse handle in the NEUTRAL position, the key switch the OFF position, and the park brake firmly engaged.
- Because of the added length of the trailer, use caution when making turns.
- Never transport the vehicle on a trailer with a load in the vehicle cargo bed.
- Remove the vehicle windshield and secure the seats before transporting on a trailer.

If the vehicle must be transported over long distances or on public highways, it should be transported on an approved trailer that has an approved load rating of 2000 lb. (908 kg) per vehicle being transported.

**NOTE:** A two-car trailer should be rated at 2 x 2000 lb. = 4000 lb. (2 x 908 kg = 1816 kg).

---

**STORAGE**

See General Warnings on page 10.

**⚠ DANGER**

- Never attempt to drain gasoline when the engine is hot or while it is running.
- Be sure to clean up any spilled gasoline before operating the vehicle.
- Store gasoline in an approved gasoline container only. Store in a well-ventilated area away from sparks, open flames, heaters, or heat sources.
- Keep gasoline out of the reach of children.
- Do not siphon gasoline from the vehicle.

**⚠ WARNING**

- Turn the key switch to the OFF position, remove the key, and leave the Forward/Reverse handle in the NEUTRAL position during storage. This is to prevent unintentionally starting the vehicle or a fire hazard.
- Turn the fuel shut-off valve to the closed (OFF) position (Figure 11, Page 24).
- Do not attempt to charge frozen batteries or batteries with bulged cases. Discard the battery. Frozen batteries can explode.

**⚠ CAUTION**

- Batteries in a low state of charge will freeze at low temperatures.

**PREPARING THE VEHICLE FOR EXTENDED STORAGE**

1. Unload the vehicle so that tires are supporting only the weight of the vehicle.
2. Store vehicle in a cool, dry place. This will minimize battery self-discharge. If the battery appears to be weak, have it charged by a trained technician. Use an automotive-type 12-volt battery charger rated at 10 amps or less.
3. Drain carburetor and seal the fuel tank.

- 3.1. Place the Forward/Reverse handle in the NEUTRAL position. Turn the fuel shut-off valve to the closed (OFF) position (**Figure 11**) and run the engine until fuel remaining in the carburetor and fuel lines is depleted and the engine stalls.
- 3.2. Loosen, but do not remove, the carburetor drain screw and drain fuel remaining in bowl into a small clean container, then pour the fuel from the container into vehicle fuel tank. Tighten the carburetor drain screw.
- 3.3. Fill fuel tank to about 1 inch (2.5 cm) from top of fuel tank and, following manufacturer's directions, add a commercially available fuel stabilizer (such as Sta-Bil<sup>®</sup>).
- 3.4. Disconnect fuel vent line from fuel tank vent nipple.
- 3.5. Plug the fuel tank vent nipple so that it is air tight. We recommend using a slip-on vinyl cap
4. Disconnect the battery cables, negative (-) cable first.
5. Batteries should be clean and free of corrosion. Wash tops and terminals of batteries with a solution of baking soda and water (1 cup (237 mL) baking soda per 1 gallon (3.8 L) of water). Rinse solution off batteries. Do not allow this solution to enter the batteries. Be sure terminals are tight. Let the terminals dry and then coat them with Battery Terminal Protector Spray (CCI P/N 1014305).

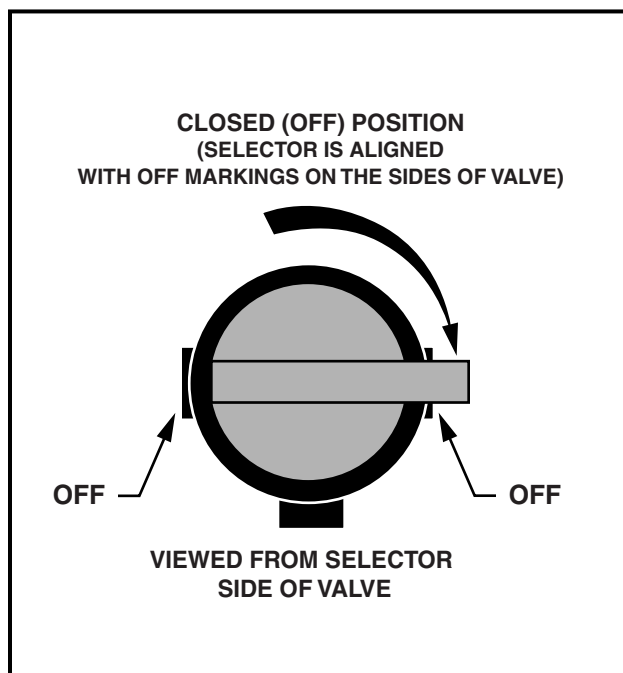

Figure 11 Fuel Shut-off Valve – Closed Position

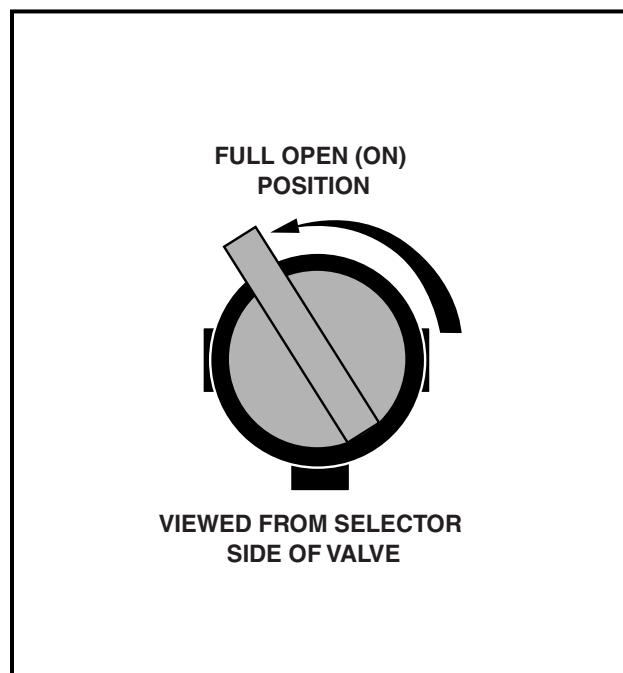
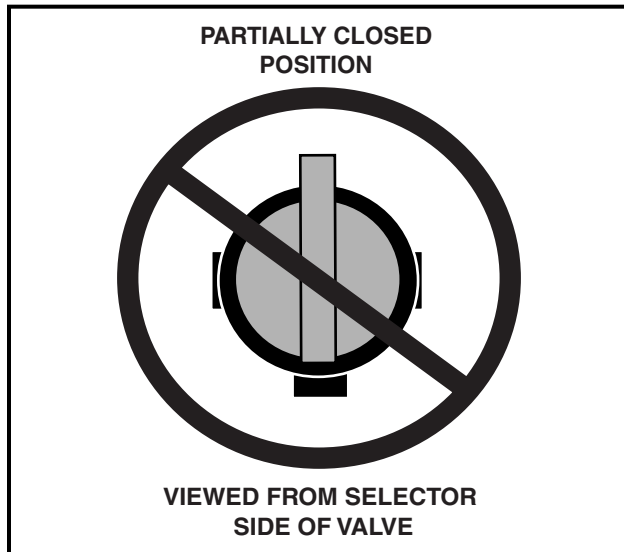

Figure 12 Fuel Shut-off Valve – Open Position



**Figure 13 Incorrect Fuel Shut-off Valve Setting**

6. To protect the engine, remove spark plug and pour 1/2 ounce (14.2 mL) of SAE 10 weight oil into the engine through the spark plug hole. Rotate engine crankshaft by hand several times and then install the spark plug.
7. Adjust tires to recommended tire pressure. **See Vehicle Specifications on page 35.**
8. Perform semiannual periodic lubrication. **See Periodic Lubrication Schedule on page 29.**
9. Thoroughly clean front body, rear body, seats, cargo bed, engine compartment, and underside of vehicle.
10. Do not engage the park brake. Chock the wheels to prevent the vehicle from rolling.

## RETURNING THE STORED VEHICLE TO SERVICE

1. Restore fuel system to operation.
  - 1.1. Remove plug from fuel tank vent.
  - 1.2. Connect vent tube to fuel tank vent.
2. Connect battery cables, positive (+) cable first.
3. Completely open the fuel shut-off valve (**Figure 12, Page 24**). Make sure the valve is fully open. A partially closed fuel shut-off valve (**Figure 13, Page 25**) combined with the use of the choke can result in a fouled spark plug and engine failure.
4. Place the Forward/Reverse handle in the NEUTRAL position. Crank the engine until fuel is pumped into the carburetor and fuel lines and the engine starts. Turn the engine off. **See following NOTE.**

**NOTE:** Due to the oil added to the engine in preparation for storage, engine may smoke excessively for a short time when it is run it for the first time after storage.

5. Adjust tires to recommended tire pressure. **See Vehicle Specifications on page 35.**
6. Perform the Pre-Operation and Daily Safety Checklist on page 17.

---

## MAINTENANCE

---

### See General Warnings on page 10.

To ensure trouble-free vehicle performance, it is very important to follow an established preventive maintenance program. Regular and consistent vehicle maintenance can prevent vehicle downtime and expensive repairs that result from neglect. Use the Pre-Operation and Daily Safety Checklist on page 17 and the following Periodic Service Schedule and Periodic Lubrication Schedule to keep the vehicle in proper working condition.

Any vehicle not functioning correctly should be removed from use until it is properly repaired. This will prevent further damage to the vehicle and avoid the possibility of injury due to unsafe conditions.

Contact your local Club Car dealer for repairs and semiannual and annual periodic service.

### **WARNING**

- If any problems are found during scheduled inspection or service, do not operate the vehicle until repairs are made. Failure to make necessary repairs could result in fire, property damage, severe personal injury, or death.
- Do not wear loose clothing or jewelry, such as rings, watches, chains, etc., when servicing the vehicle.
- Turn the key switch to the OFF position, remove the key, place the Forward/Reverse handle in the NEUTRAL position, and chock the wheels prior to servicing.
- Moving parts – Do not attempt to service vehicle while the engine is running.
- Do not work on vehicle powertrain or under the cargo bed when it is loaded.
- Turn the fuel shut-off valve to the closed (OFF) position (Figure 11, Page 24).
- Hot! Do not attempt to service hot engine or exhaust system. Attempting to do so could cause severe burns.
- For vehicles with cargo beds, remove all cargo before raising the bed or servicing the vehicle. If the vehicle is equipped with a prop rod, ensure that it is securely engaged. Do not close bed until all persons are clear of cargo bed area. Keep hands clear of all crush areas. Do not drop cargo bed; lower gently and keep entire body clear. Failure to heed this warning could result in severe personal injury or death.
- To avoid unintentionally starting the vehicle:
  - Disconnect battery cables, negative (–) cable first (Figure 1, Page 9).
  - Disconnect the spark plug wire from the spark plug.
- If wires are removed or replaced make sure wiring and wire harness are properly routed and secured. Failure to properly route and secure wiring could result in vehicle malfunction, property damage, personal injury, or death.
- Lift only one end of the vehicle at a time. Use a suitable lifting device (chain hoist or hydraulic floor jack) with 1000 lb. (454 kg) minimum lifting capacity. Do not use lifting device to hold vehicle in raised position. Use approved jack stands of proper weight capacity to support the vehicle and chock the wheels that remain on the floor. When not performing a test or service procedure that requires movement of the wheels, lock the brakes.

## PERIODIC SERVICE SCHEDULE

---

See General Warnings on page 10.

### **WARNING**

- Service, repairs, and adjustments must be made per instructions in the appropriate maintenance and service manual.

**NOTE:** *If the vehicle is constantly subjected to heavy use or severe operating conditions, the preventive maintenance procedures should be performed more often than recommended in the Periodic Service and Lubrication Schedules.*

*Both the Periodic Service Schedule and the Periodic Lubrication Schedule must be followed to keep vehicle in optimum operating condition.*

PERIODIC SERVICE SCHEDULE		
REGULAR INTERVAL	SERVICE	
Monthly service by owner or trained technician	Engine	Check engine oil level; change if necessary. <b>See Periodic Lubrication Schedule on page 29.</b>
		Check engine cooling air intake; visually inspect unshrouded area around engine exhaust for grass and debris and clean if necessary.
	Tires	Check air pressure and adjust if necessary. <b>See Vehicle Specifications on page 35.</b>
	General vehicle	Wash engine compartment and underside of vehicle. Do not wash engine when hot.
Semiannual service by trained technician only (or every 50 hours of operation, whichever comes first)	Battery	Clean terminals and wash dirt from casing; check electrolyte level. <b>See page 33.</b>
	Front wheel alignment and toe-in	Check and adjust if necessary. <b>See Section 7 – Steering and Front Suspension in the appropriate maintenance and service manual.</b>
	Electrical wiring and connections	Check for tightness and damage.
	Brake system	Inspect master cylinder, wheel cylinders, brake lines, and hoses for damage or leakage.
Check park brake cables for damage; replace if necessary.		
Check brake shoes and drums; replace if necessary. <b>See Section 6 – Wheel Brake Assemblies in the appropriate maintenance and service manual.</b>		
Annual service by trained technician only (or every 100 hours of operation, whichever comes first)	Engine	Check for leaks around gaskets, fill plugs, etc.
		Inspect, clean and gap spark plug; replace if necessary.
	Engine air intake system	Check air filter element; clean or replace if necessary.
		Check clamps for tightness; check hose for cracks.
General vehicle	Check for loose hardware and tighten if necessary.	
Two year service by trained technician only (or every 200 hours of operation, whichever comes first)	Fuel filters	Replace. Dispose of used filters properly.

## PERIODIC LUBRICATION SCHEDULE

PERIODIC LUBRICATION SCHEDULE			
REGULAR INTERVAL	SERVICE	LUBRICATION POINTS	RECOMMENDED LUBRICANT
Semiannually by owner or trained technician (or every 50 hours of operation, whichever comes first)	Brake pedal shaft bearings	1	Dry Moly Lube (CCI P/N 1012151)
	Accelerator push rod pivots, mounts, and shifter cable pivots	2	Dry Moly Lube (CCI P/N 1012151)
	Front suspension (2 fittings)	3	Chassis Lube (EP NLGI Grade 2)
	Check/add brake fluid	4	Use only DOT-5 (silicone) brake fluid
Annually by trained technician only (or every 100 hours of operation, whichever comes first)	Check/fill unitized transaxle to plug level	5	<b>MC012C-AS00 transaxle</b> 29 oz. (.85 liters) 80-90 WT. API class GL-3 or 80-90 WT. AGMA class 5 EP gear lubricant.
	Inspect front wheel bearings (Repack as necessary)	6	Chassis Lube (EP NLGI Grade 2)
First change 100 hours – additional change every 200 hours of operation or annually, whichever comes first	Change engine oil and oil filter: FE350 and FE400	7	32 oz. (.95 liter) without filter; 38 oz. (1.12 liters) with filter

**NOTE:** The fuel tank is located under the front passenger seat on the Carryall 472 vehicle.

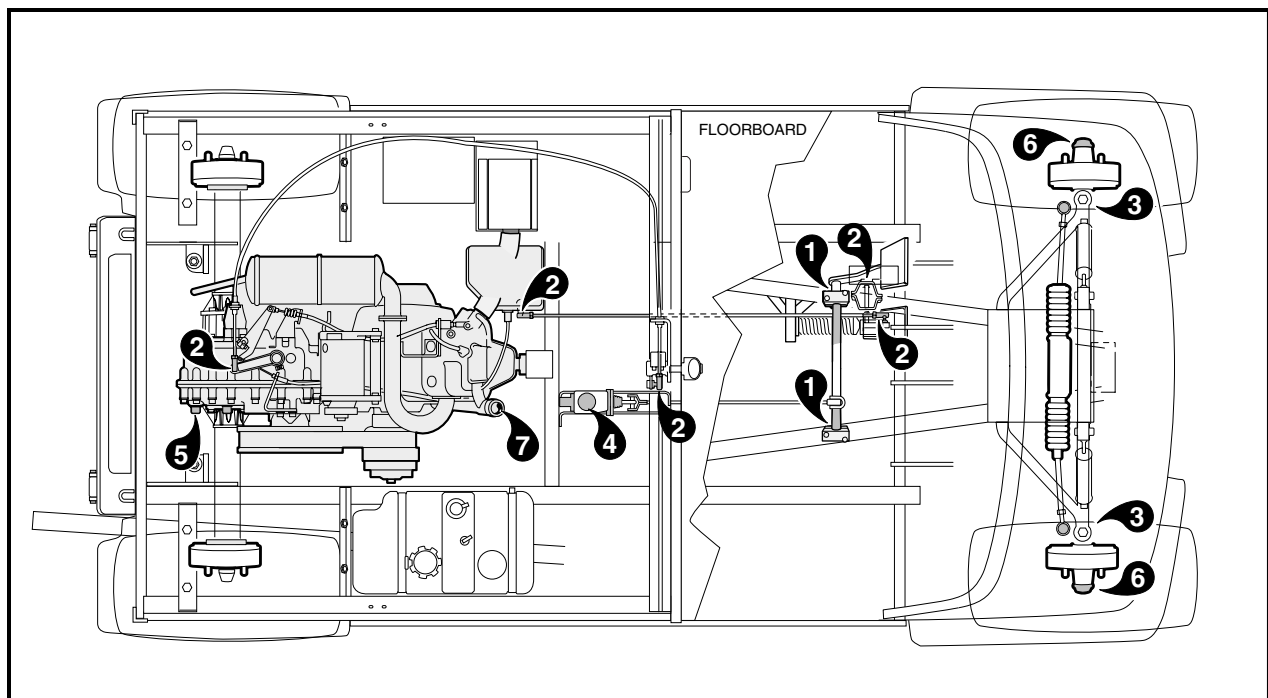

Figure 14 Lubrication Points

## MASTER CYLINDER

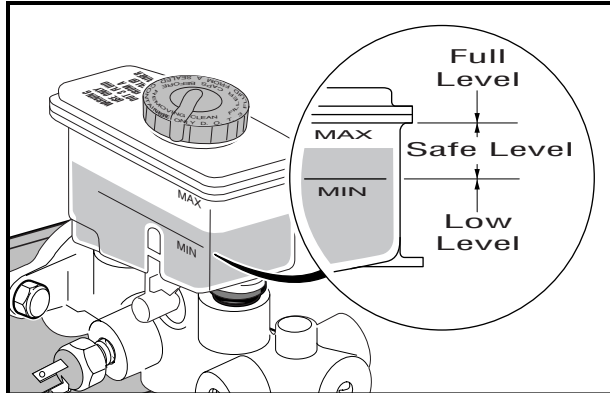

Figure 15 Brake Fluid Reservoir

The master cylinder is located under the passenger seat toward the center of the vehicle (**Figure 15, Page 30**). Raise or remove the seat to check the brake fluid level.

When checking the brake fluid, also inspect the following:

- The presence of brake fluid on the exterior surface of the master cylinder indicates a leak.
- The vent holes in the reservoir cover should be clean and open.
- The reservoir diaphragm should not have holes or other damage.

### BRAKE FLUID

Brake fluid level should be within 1/4 inch (6 mm) from top of reservoir (**Figure 15**). Also, brake fluid should be clean with no residue in bottom of reservoir or other evidence of contamination.

#### **⚠ CAUTION**

- Use only DOT-5 (silicone) brake fluid. Use of any other type brake fluid is not recommended.

## ENGINE OIL LEVEL CHECK

Even though the low oil warning light on the instrument panel should illuminate if oil becomes low, the engine oil level should be checked monthly. The vehicle should be on a level surface when checking oil. Do not overfill with oil.

1. Remove the oil level dipstick from the oil filler tube and wipe oil from stick (**Figure 16 or Figure 17**). See following **CAUTION**.

#### **⚠ CAUTION**

- Do not remove dipstick while engine is running.
2. Check oil by fully inserting the dipstick into the oil filler tube and immediately removing it.



- If the oil level is at or below the low level mark on the dipstick gauge, add oil until the level is between low and full levels (safe level).

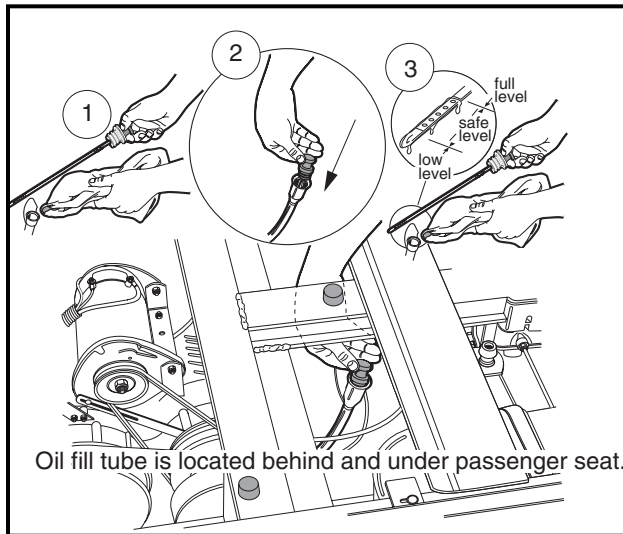

Figure 16 Engine Oil Level Check – 272 Vehicle

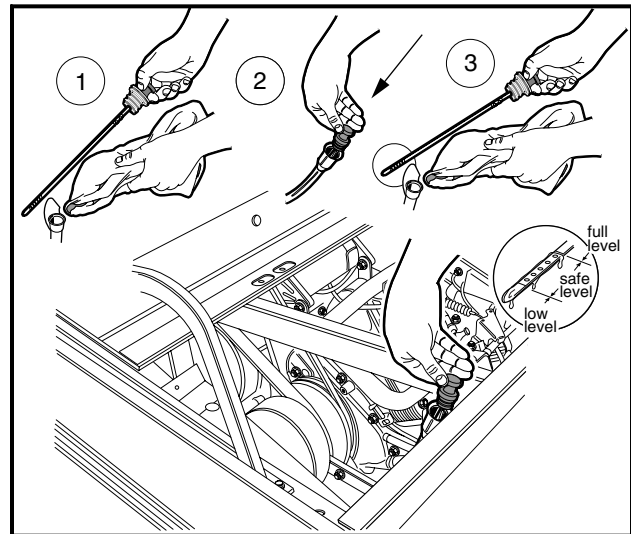

Figure 17 Engine Oil Level Check – 472 Vehicle

## OIL VISCOSITY

Choose the viscosity according to the temperature as follows:

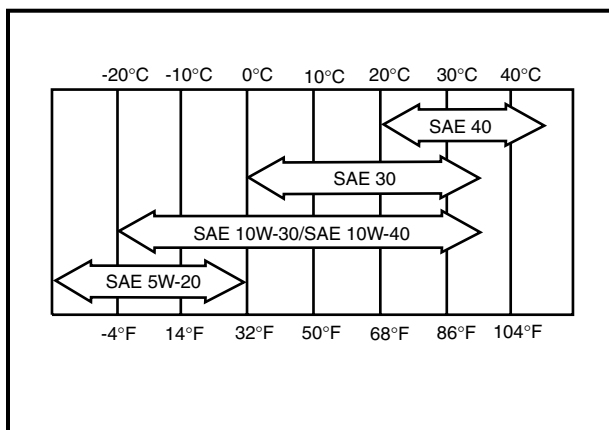

Figure 18 Oil Viscosity Chart

**NOTE:** Using multi-grade oils (5W-20, 10W-30, and 10W-40) will increase oil consumption. Check oil level more frequently when using them.

## FUELING INSTRUCTIONS

See General Warnings on page 10.

### **⚠ DANGER**

- Turn the key switch to the OFF position before fueling.
- Never pour gasoline into the fuel tank when the engine is hot or while it is running.
- To avoid electric arc caused by static electricity, the fuel storage/pumping device must be grounded. If the pump is not grounded, the vehicle must be grounded to the pump before and during the fueling operation.
- If the vehicle has an all-weather enclosure installed, be sure the fuel tank is properly vented as shown (Figure 19 or Figure 20).
- To avoid the possibility of fire, clean up any spilled gasoline before operating the vehicle.

### **⚠ CAUTION**

- To allow for expansion, do not fill higher than one inch (2.54 cm) from the top of the fuel tank. Avoid spilling fuel.

**NOTE:** Whenever possible, avoid using oxygenated fuels and fuels that are blended with alcohol. Vehicles to be stored for extended periods should be prepared for storage as instructed on page 23 of this manual.

1. Remove the passenger seat.
2. Remove fuel cap and fill tank with fresh unleaded gasoline only. See preceding **DANGER, CAUTION, and NOTE.**
3. Replace fuel cap on tank. Ensure cap is tightened securely.
4. Replace passenger seat.

### **⚠ WARNING**

- Make sure seat hinges and latch are securely engaged before operating vehicle.

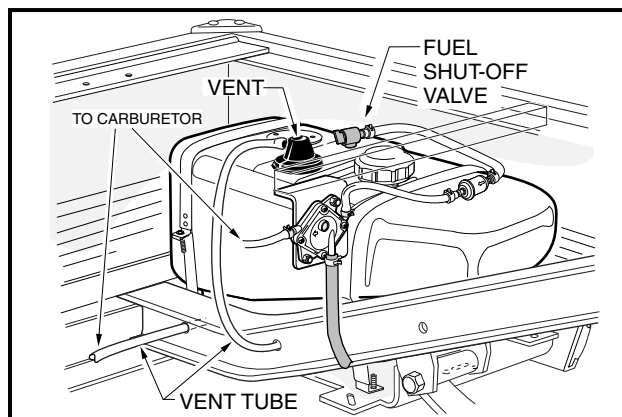

Figure 19 Fuel Tank – 272 Vehicle

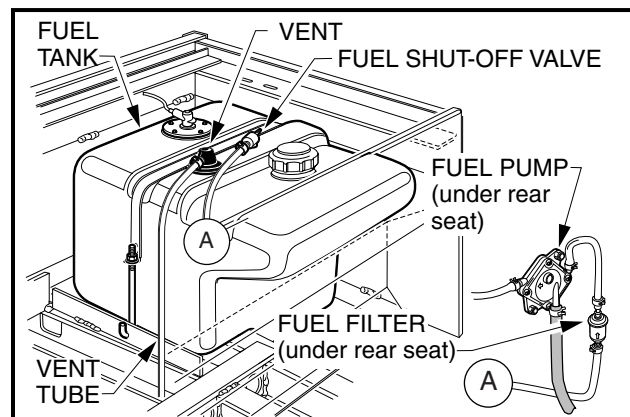

Figure 20 Fuel Tank – 472 Vehicle

## BATTERY

See General Warnings on page 10.

### **⚠ DANGER**

- **Battery – Explosive gases! Do not smoke. Keep sparks and flames away from the vehicle and service area. Ventilate when charging or operating vehicle in an enclosed area. Wear a full face shield and rubber gloves when working on or near batteries.**
- **Tools, wires, and metal objects can cause sparks when shorted across a battery.**
- **Follow all instructions carefully when working with batteries.**
- **Charge battery in a well-ventilated area only.**
- **Battery – Poison! Contains acid! Causes severe burns. Avoid contact with skin, eyes, or clothing. Antidotes:**
  - **External: Flush with water. Call a physician immediately.**
  - **Internal: Drink large quantities of milk or water followed with milk of magnesia or vegetable oil. Call a physician immediately.**
  - **Eyes: Flush with water for 15 minutes. Call a physician immediately.**

### **⚠ WARNING**

- **Do not jump-start the vehicle. To charge the battery, use an automotive-type 12-volt charger rated at 10 amps or less.**

The battery in the gasoline vehicle is a 12-volt, low-maintenance battery that requires infrequent watering (**Figure 21**).

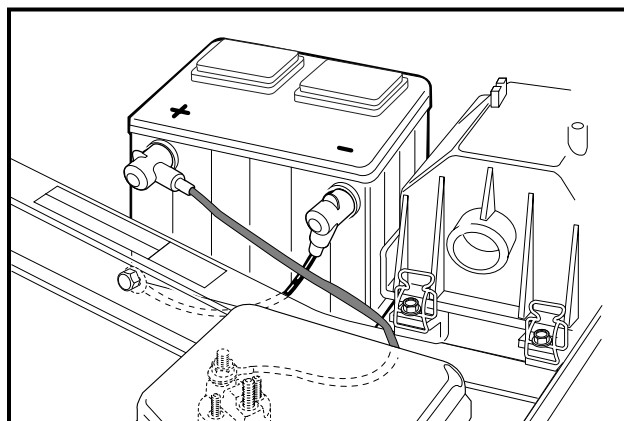

Figure 21 Battery

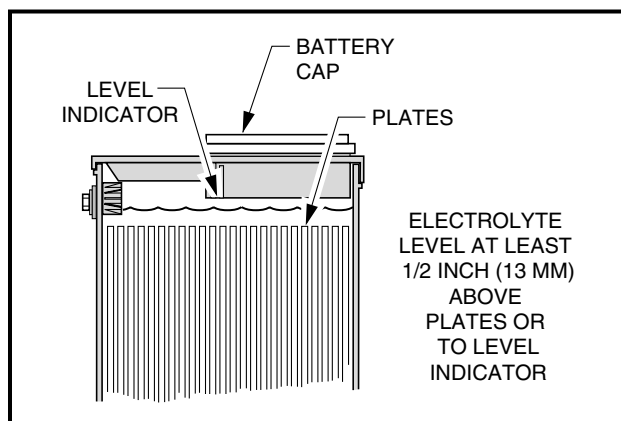

Figure 22 Battery Electrolyte Level

Any corrosion around the positive (+) or negative (–) terminals should be washed off with a solution of baking soda and water (1 cup (237 mL) baking soda per 1 gallon (3.8 L) of water). Rinse solution off the battery. Do not allow this solution to enter the battery. Be sure terminals are tight (battery terminals should be tightened to 20 ft-lb (27.1 N·m)). Let the terminals dry and then spray them with Battery Terminal Protector Spray (CCI 1014305). **See following CAUTION.**

## **⚠ CAUTION**

- **If battery wire terminals are damaged or corroded, replace or clean them as necessary. Failure to do so may cause them to overheat during operation.**

Be sure battery clamp is properly tightened. Tighten to 12 ft-lb (16.3 N·m). A loose clamp may allow the battery to become damaged from vibration or jarring.

If battery appears weak, have it charged by a trained technician. The battery should never be left discharged any longer than absolutely necessary (do not leave discharged overnight).

## **CLEANING THE VEHICLE**

The vehicle is equipped with an ABS/DR acrylic front body, an all-aluminum rear body, and a powder-coated steel cargo bed. Use a commercially available automotive cleaning solution with a sponge or soft cloth for normal cleaning. A garden hose at normal residential water pressure is adequate. To remove oxidation or discoloration from aluminum, use a commercially available aluminum cleaner paste and fine grade (No. 00) steel wool.

Club Car does not recommend any type of pressure washing or steam cleaning. Such a process will expose electrical components to moisture. Moisture entering electrical components can result in water damage and subsequent component failure.

Use non-abrasive wax products. Battery acid, fertilizers, tars, asphalt, creosote, paint, or chewing gum should be removed immediately to prevent possible stains.

The front body is made of an ABS/DR acrylic material similar to the material used to manufacture hot tubs and shower/tub units. Cleaning and repair techniques for the front body are the same as those used on conventional acrylic sheet. Repair kits, cleaning and polishing products may be purchased at any hardware store where ABS/DR acrylic (hot tubs and shower/tub units) are sold.

The seats of the vehicle will last longer with proper cleaning. Use a solution of 10% liquid soap and warm water applied with a soft cloth. For imbedded dirt, a soft bristle brush may be used. For heavy soiling, difficult stains, or scratches, blemishes, or other body damage, see Section 4 of the maintenance and service manual. **See following NOTE.**

***NOTE:** Dispose of waste water properly.*

## **ACCESSORIES**

There is a complete line of accessory equipment available from Club Car and our dealers/distributors. You can obtain the name and phone number of your closest Club Car contact by visiting our web site at [www.clubcar.com](http://www.clubcar.com) and clicking the "Find a Dealer" link.

Care should be taken that these accessories are properly installed by trained technicians, and they are used in the manner for which they were designed. **See following WARNING.**

## **⚠ WARNING**

- **Custom cab assemblies, canopy tops, weatherproof enclosures, and windshields will not protect occupants from flying objects.**
- **If the vehicle is equipped with an electric powered bed lift, remove the bed before servicing the bed lift system.**

## SUBSEQUENT OWNER REGISTRATION

In the event a vehicle is bought as a used vehicle, we strongly urge the new owner to register the vehicle with Club Car. This will enable us to contact you if the need arises. Please send your name, address, and serial number of the vehicle to Club Car, Inc., P.O. Box 204658, Augusta, Georgia 30917-4658, Attention: Vehicle Registration.

## VEHICLE SPECIFICATIONS

SPECIFICATIONS	CARRYALL 272 TURF 272	CARRYALL 472
<b>POWER SOURCE</b>		
<b>Engine:</b> 4-cycle OHV, 400 cc, 13 hp rated, single-cylinder, air-cooled, with pressure lubrication system	•	•
<b>Fuel system:</b> Side-draft carburetor with float bowl, fixed jets, fuel filters, and impulse fuel pump	•	•
<b>Governor:</b> Automatic ground-speed sensing, internally-geared in unitized transaxle	•	•
<b>Ignition:</b> Transistor electronic ignition with electronic RPM limiter	•	•
<b>Unitized transaxle, MC012C-AS00:</b> Fully synchronized forward and reverse with neutral (14.9:1 forward, 20.5:1 reverse) and differential lock feature	•	•
<b>Electrical system:</b> 12 volt, 500 cca at 0 °F (-17.8 °C), 650 at 32 °F (0 °C). 105-minute reserve capacity and 35-amp charging capacity	•	•
<b>Torque converter:</b> Automatic, variable-speed, dry type	•	•
<b>STEERING/SUSPENSION/BRAKES</b>		
<b>Steering:</b> Self-adjusting rack and pinion, Ackerman	•	•
<b>Suspension:</b> <b>Front:</b> Independent A-arms with coil-over shocks <b>Rear:</b> Semi-independent suspension with multi-leaf springs and dual hydraulic shocks	•	•
<b>Brakes:</b> Hydraulic brake system – self-adjusting drum brakes on each wheel with separate hand-operated park brake	•	•
<b>BODY/CHASSIS</b>		
<b>Frame/Chassis:</b> Twin I-Beam welded aluminum	•	•
<b>Side and rear body:</b> All aluminum with aluminum cargo bed	•	•
<b>Front body:</b> ABS/DR acrylic cap	•	•
<b>Tires:</b> 23 x 10.50 – 12 tubeless, 4-ply rated load range, front and rear	•	•
<b>DIMENSIONS/WEIGHT</b>		
<b>Overall length</b> (box bed configuration)	120 in. (305 cm)	141 in. (317.8 cm)
<b>Overall width</b>	54 in. (137 cm)	
<b>Overall height</b> (at steering wheel)	51 in. (130 cm)	
<b>Wheelbase</b>	80 in. (203 cm)	101 in. (256 cm)
<b>Ground clearance:</b> under differential under foot platform	6.6 in. (17 cm) 11.4 in. (29 cm)	6.6 in. (17 cm) 11.4 in. (29 cm)
<b>Front wheel tread</b>	43 in. (109 cm)	
<b>Rear wheel tread</b>	44.5 in. (111 cm)	
<b>Specifications continued on next page...</b>		

<b>SPECIFICATIONS</b>	<b>CARRYALL 272 TURF 272</b>	<b>CARRYALL 472</b>
<b>Weight (dry):</b> with all-terrain tread with turf tread	1106 lb. (501.7kg) 1066 lb. (477.2 kg)	1200 lb. (544.2 kg) 1160 lb. (526.0 kg)
<b>Forward speed</b>	17-19 mph (27-31 km/h)	
<b>Governed RPM:</b> FE400 Engine	3850 (±30) RPM	
<b>Curb clearance circle</b> (diameter)	24 ft. 1 in. (734 cm)	31 ft. 8 in. (965 cm)
<b>Turning radius</b> (per SAE J 695)	139.6 in. (355 cm)	15 ft. 6 in. (472.4 cm)
<b>Intersecting aisle clearance</b>	112.2 in. (285 cm)	120 in. (304 cm)
<b>Floorboard height</b>	17 in. (43 cm)	
<b>DIMENSIONS/WEIGHT, Continued</b>		
<b>Seat height</b>	35 in. (89 cm)	
<b>Load bed height</b>	31.1 in. (79 cm)	
<b>Load bed size</b> (box bed inside dimensions)	48.8 x 49.8 x 9.3 in. (121.9 x 126.4 x 24 cm) (13.0 cubic feet)	37.6 x 45.1 x 9.3 in. (96 x 115 x 23 cm) (9.13 cubic feet)
<b>Load bed size</b> (flat bed dimensions)	46.9 x 48.3 in. (119 x 123 cm)	35.8 x 44.3 in. (91 x 112 cm)
<b>Vehicle rated capacity</b> (level surface only)	1200 lb. (544 kg)	1300 lb. (590 kg)
<b>Bed load capacity</b> (level surface only)	800 lb. (363 kg)	500 lb. (227 kg)
<b>Standard seating capacity</b>	2	4
<b>LIQUID CAPACITIES</b>		
<b>Engine crankcase without filter</b>	32 oz. (.95 liters)	
<b>Engine crankcase with filter</b>	38 oz. (1.12 liters)	
<b>Unitized transaxle, MC012C-AS00</b>	29 oz. (.85 liters)	
<b>Master cylinder</b>	8 oz. (240 ml)	
<b>Fuel tank</b>	7 gallons (26.5 liters)	6.5 gallons (24.6 liters)
<b>TIRE PRESSURE</b>		
<b>All-terrain tread (standard)</b>	Front: 7-11 psi (.48-.76 Bars) Rear: 14-18 psi (.97-1.24 Bars)	Front: 7-11 psi (.48-.76 Bars) Rear: 14-18 psi (.97-1.24 Bars)
<b>Turf tread (optional)</b>	Front: 12-16 psi (.83-1.10 Bars) Rear: 16-20 psi (1.10-1.38 Bars)	Front: 12-16 psi (.83-1.10 Bars) Rear: 16-20 psi (1.10-1.38 Bars)
<b>Traks Max II tread (optional)</b>	Front: 14-16 psi (.97-1.10 Bars) Rear: 18-20 psi (1.24-1.38 Bars)	Front: 14-16 psi (.97-1.10 Bars) Rear: 18-20 psi (1.24-1.38 Bars)

---

## WHEEL AND TIRE INSTALLATION

---

**NOTE:** Upon vehicle delivery, the shipping wheel and tire assemblies must be replaced by the standard wheel and tire assemblies, which are delivered in the vehicle cargo bed.

*Do not remove the warning tag attached to the steering wheel until the shipping wheel and tire assemblies have been replaced by the standard wheel and tire assemblies.*

1. Slightly loosen the lug nuts on all four wheels.
2. Raise one end of the vehicle until the tires are off the ground by approximately 15.2 cm (six inches). **See following WARNING.**

### **WARNING**

- **Lift only one end of a vehicle at a time. Before lifting, set the park brake when lifting the front of the vehicle, unload the cargo bed, and chock the wheels that remain on the floor. Use a suitable lifting device (chain hoist or hydraulic floor jack) with 454 kg (1000 lb.) minimum lifting capacity. Do not use lifting device to hold vehicle in raised position. Use approved jack stands of proper weight capacity to support vehicle.**

3. Remove the lug nuts and the wheel.
4. Install the wheel and tire assembly and tighten lug nuts (using a crisscross pattern) until they are snug.
5. Repeat steps 3 and 4 for the other side of the vehicle.
6. Lower the vehicle to the ground and finish tightening lug nuts (using a crisscross pattern) to 74.6 N·m (55 ft-lb.).
7. Repeat steps 2-6 for the other end of the vehicle.

# CLUB CAR<sup>®</sup> LIMITED TWO YEAR WARRANTY FOR 2005 TRANSPORTATION AND UTILITY VEHICLES

---

## 1. WARRANTY:

CLUB CAR, INC., ("CLUB CAR") hereby warrants to the Original Retail Purchaser that its new 2005 Model Transportation and Utility Vehicles purchased from CLUB CAR or an authorized dealer shall be free from defects in material and workmanship under normal use and service as a transportation or utility vehicle for the periods stated below, subject to the provisions, limitations and exclusions contained in this limited warranty.

**LIMITED TWO YEAR / 2000 HOUR WARRANTY:** The engine assembly, unitized transaxle assembly (gasoline vehicle), motor, transaxle assembly (electric vehicle), main frame assembly, hydraulic dump kit, Custom Cab assembly and doors, and Driving Range Protective Enclosure are warranted with respect to parts and labor against defects in material and workmanship for a period of two years or 2000 hours of operation, whichever first occurs, from the date of purchase.

**LIMITED ONE YEAR / 1000 HOUR WARRANTY:** All remaining components of the vehicle not specified otherwise, the Portable Refreshment Center, and all other original equipment options and accessories supplied by CLUB CAR are warranted with respect to parts and labor against defects in material and workmanship for a period of one year or 1000 hours of operation, whichever first occurs, from the date of purchase.

This limited warranty covers material, workmanship and repair labor cost as to those items specifically listed above for the periods specified. Such repair labor shall be performed only by CLUB CAR, its authorized dealers, or a service agency approved by CLUB CAR.

IF THE WARRANTY REGISTRATION FORM IS NOT COMPLETED AND RETURNED TO CLUB CAR AT THE TIME OF THE ORIGINAL RETAIL SALE, PURCHASER MUST PROVIDE PROOF OF DATE OF PURCHASE WITH ANY WARRANTY CLAIM.

## 2. EXCLUSIONS:

Excluded from any CLUB CAR warranty are all fuses, filters, decals (except safety decals), spark plugs, light bulbs, lubricants, trim pieces, seats, routine wear items such as the charger plug and receptacle, brake shoes, belts, brushes, bushings, engine mounts, mats and pads, maintenance adjustments, cosmetic deterioration, and items which deteriorate or fail due to exposure or ordinary wear and tear. Batteries, battery charger, onboard computer, and solid-state speed controller are covered under separate CLUB CAR warranties. Also excluded from any CLUB CAR warranty is damage to a vehicle or component resulting from a cause other than a defect including unreasonable or unintended strain or use, improper installation of accessories, installation of parts or accessories that are not original equipment, overloading, accident, alteration, abuse or neglect.

Transportation expenses for warranty services are also excluded from this warranty.

## 3. VOIDING OF WARRANTY:

THIS AND ANY OTHER WARRANTY SHALL BE VOID IF THE VEHICLE IS ABUSED OR USED IN AN UNINTENDED MANNER OR SHOWS INDICATIONS THAT IT HAS BEEN ALTERED IN ANY WAY, INCLUDING, BUT NOT LIMITED TO, MODIFICATION OF THE SPEED GOVERNOR, BRAKING SYSTEM, STEERING, TRANSAXLE, OR OTHER OPERATING SYSTEMS OF THE VEHICLE TO CAUSE IT TO PERFORM OUTSIDE CLUB CAR SPECIFICATIONS. THE WARRANTY IS LIKEWISE VOID IF THE VEHICLE INVOLVED SHOWS INDICATIONS THAT REASONABLE OR NECESSARY MAINTENANCE AS OUTLINED IN THE OWNER'S MANUAL AND MAINTENANCE AND SERVICE MANUAL WAS NOT PERFORMED AT THE TIME AND IN THE MANNER SPECIFIED IN SUCH MANUALS.

## 4. SOLE REMEDY:

CLUB CAR's liability under this limited warranty, or in any action whether based upon warranty, contract, negligence, strict product liability or otherwise, shall be the repair or replacement, at CLUB CAR's option, of the vehicle or component thereof that CLUB CAR deems to be defective. Replacement shall mean furnishing, during the applicable limited warranty period, a new vehicle or factory-reconditioned vehicle or component thereof that is identical or reasonably equivalent to the warranted product or component at no cost to the purchaser. Repair shall mean remedying a defect in the vehicle or component thereof at no cost to the purchaser during the applicable limited warranty period. If CLUB CAR elects to repair the vehicle, it may provide factory-reconditioned parts or components. All parts and components replaced under warranty shall become the property of CLUB CAR.

## 5. HOW TO MAKE A WARRANTY CLAIM:

To make a warranty claim under this limited warranty, you must present the vehicle or defective component to an authorized CLUB CAR dealer or send the defective component, freight prepaid, to WARRANTY SERVICES, CLUB CAR, INC., 4125 Washington Road, Evans, Georgia 30809, U.S.A., 706-863-3000.



**6. DISCLAIMER:**

**THIS LIMITED WARRANTY IS EXCLUSIVE. CLUB CAR MAKES NO OTHER WARRANTY OF ANY KIND, EXPRESSED OR IMPLIED. ANY IMPLIED WARRANTIES OF MERCHANTABILITY OR FITNESS FOR A PARTICULAR PURPOSE WHICH EXCEED THE OBLIGATIONS OR TIME LIMITS STATED IN THIS WARRANTY ARE HEREBY DISCLAIMED BY CLUB CAR AND EXCLUDED FROM THIS WARRANTY. THE PURCHASER AND CLUB CAR EXPRESSLY AGREE THAT THE REMEDY OF THE REPLACEMENT OR REPAIR OF THE DEFECTIVE VEHICLE OR COMPONENT THEREOF IS THE SOLE REMEDY OF THE PURCHASER. CLUB CAR MAKES NO OTHER REPRESENTATION OR WARRANTY OF ANY KIND, AND NO REPRESENTATIVE, EMPLOYEE, OR DEALER OF CLUB CAR HAS THE AUTHORITY TO MAKE OR IMPLY ANY REPRESENTATION, PROMISE OR AGREEMENT, WHICH IN ANY WAY VARIES THE TERMS OF THIS WARRANTY.**

**7. NO CONSEQUENTIAL DAMAGES:**

**IN NO EVENT SHALL CLUB CAR BE LIABLE FOR ANY INCIDENTAL OR CONSEQUENTIAL DAMAGES INCLUDING, BUT NOT LIMITED TO, LOSS RELATED TO PROPERTY OTHER THAN THE VEHICLE, LOSS OF USE, LOSS OF TIME, INCONVENIENCE, OR ANY OTHER ECONOMIC LOSS.**

Some states allow neither limitation on the duration of an implied warranty nor exclusions or limitation of incidental or consequential damages. Therefore, the above limitations or exclusions may not apply to you.

This warranty gives you specific legal rights, and you may also have other rights, which vary from state to state.

**8. INFORMATION:**

For further information contact WARRANTY SERVICES, CLUB CAR, INC., P.O. Box 204658, Augusta, Georgia 30917-4658, U.S.A., 706-863-3000.

**9. WARNING:**

Any modification or alteration of any vehicle beyond factory specifications, including those that affect the weight distribution, stability, or speed of the vehicle, can cause serious personal injury or death.





**Manual No. 102680217**  
**Edition Code 0704A00000**  
**English**



Manufactured by  
**Club Car, Inc.**  
P.O. Box 204658  
Augusta, GA 30917-4658  
USA

**Web** [www.clubcar.com](http://www.clubcar.com)  
**Phone** 1.706.863.3000  
1.800.ClubCar  
**Int'l** +1 706.863.3000  
**Fax** 1.706.863.5808