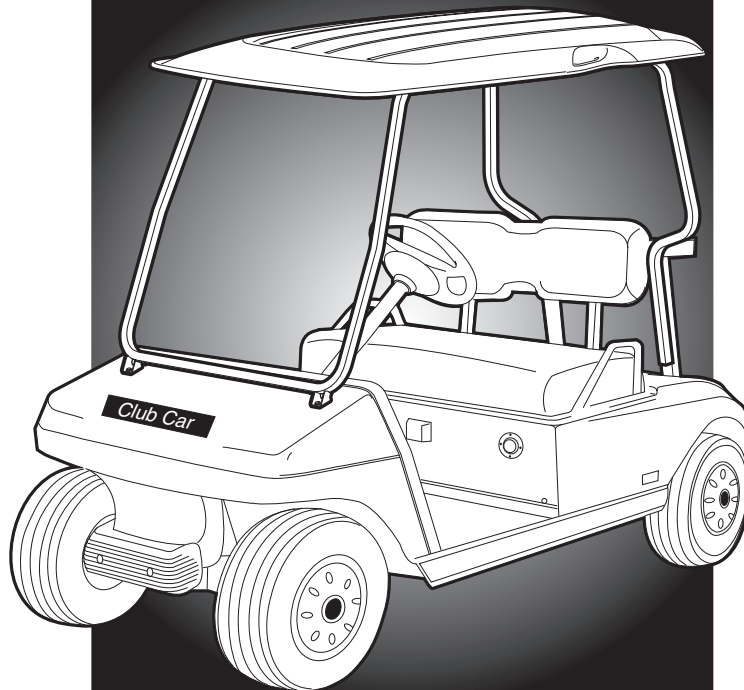


# Club Car

®

## 2003 MAINTENANCE SERVICE SUPPLEMENT



### IQ SYSTEM ELECTRIC VEHICLES

MANUAL NUMBER 102318806  
EDITION CODE 1202D0707B



## FOREWORD

---

Club Car vehicles are designed and built to provide the ultimate in performance efficiency; however, proper maintenance and repair are essential for achieving maximum service life and continued safe and reliable operation.

This supplement provides detailed information for the maintenance and repair of IQ Plus™ electric vehicles and should be used in conjunction with the appropriate maintenance and service manual.

If you do not have the appropriate maintenance and service manual, you may order one from your local Club Car representative. Maintenance and service manuals available include the following:

**2003 DS Golf Car Maintenance & Service Manual**

**Publication Part No. 102318801**

**2003 Transportation Vehicle Maintenance & Service Manual**

**Publication Part No. 102318803**

This supplement and corresponding maintenance and service manual should be thoroughly reviewed prior to servicing the vehicle. The procedures provided must be properly implemented, and the DANGER, WARNING, and CAUTION statements must be heeded.

This supplement was written for the trained technician who already has knowledge and skills in electrical and mechanical repair. If the technician does not have such knowledge and skills, attempted service or repairs to the vehicle may render the vehicle unsafe. For this reason, Club Car advises that all repairs and/or service be performed by an authorized Club Car distributor/dealer representative or by a Club Car factory-trained technician.

It is the policy of Club Car, Inc. to assist its distributors and dealers in continually updating their service knowledge and facilities so they can provide prompt and efficient service for vehicle owners. Regional technical representatives, vehicle service seminars, periodic service bulletins, maintenance and service manuals, and other service publications also represent Club Car's continuing commitment to customer support.

This supplement, used in conjunction with the appropriate maintenance and service manual, covers all aspects of typical vehicle service; however, unique situations do sometimes occur when servicing a vehicle. If it appears that a service question is not answered in this supplement, you may write to us at: Club Car, Inc., P.O. Box 204658; Augusta, Georgia 30917-4658, USA, Attention: Technical Services, or contact a Club Car Technical Service Representative at (706) 863-3000, ext. 3580.

This supplement does not contain maintenance and service procedures for the battery charger. Contact your local Club Car representative for information on how to obtain the appropriate battery charger maintenance and service manual.

Copyright © 2002, 2006, 2007 Club Car, Inc.  
*Club Car* is a registered  
trademark of Club Car, Inc.

This manual effective June 11, 2002

## **WARNING**

- **Read Section 1 – Safety in the appropriate maintenance and service manual before attempting any service on the vehicle.**
- **Before servicing vehicle, read complete section(s) and any referenced information that may be relevant to the service or repair to be performed.**

**NOTE:** *This supplement represents the most current information at the time of publication. Club Car, Inc. is continually working to further improve its vehicles and other products. These improvements may affect servicing procedures. Any modification and/or significant change in specifications or procedures will be forwarded to all Club Car distributors/dealers and will, when applicable, appear in future editions of this supplement.*

*Club Car, Inc. reserves the right to change specifications and designs at any time without notice and without the obligation of making changes to units previously sold.*

*There are no warranties expressed or implied in this supplement. See the limited warranty found in the vehicle owner's manual or write to: Club Car, Inc., P.O. Box 204658, Augusta, Georgia 30917-4658, USA, Attention: Warranty Administration.*

# CONTENTS

---

## SECTION 10 – PERIODIC MAINTENANCE

---

General Warning .....	10-1
General Information .....	10-2
Pre-Operation and Daily Safety Checklist .....	10-3
Performance Inspection .....	10-3
Periodic Service Schedule .....	10-4
Periodic Lubrication Schedule .....	10-6

## SECTION 11 – ELECTRICAL SYSTEM AND TESTING

---

General Information .....	11-1
Electrical Circuits .....	11-2
Control Circuit .....	11-2
Power Circuit .....	11-8
Charge Circuit .....	11-9
Wiring Diagram .....	11-10
Troubleshooting .....	11-11
Troubleshooting the Vehicle with the IQDM .....	11-11
Troubleshooting Guide 1 .....	11-11
Troubleshooting Guide 2 .....	11-14
Test Procedures .....	11-16
Index of Test Procedures .....	11-16
Communication Display Module (CDM) .....	11-41
Using the CDM to Retrieve Data from the Onboard Computer .....	11-42
CDM Troubleshooting Guide .....	11-43

## SECTION 12 – IQ DISPLAY MODULE (IQDM) AND IQDM-P DIAGNOSTICS

---

Plugging the Handset into the Vehicle .....	12-1
Introductory Display .....	12-2
Menu Navigation .....	12-2
Monitor Menu .....	12-4
Faults Menu .....	12-6
Functions Menu .....	12-10
Get Settings From Controller .....	12-10
Write Settings to Controller .....	12-11
Reset All Settings .....	12-13
Information .....	12-13

Programmer Setup .....	12-13
Program .....	12-14
Faults .....	12-14
Information .....	12-14
IQDM and IQDM-P Handset Troubleshooting .....	12-15
Test Procedures .....	12-16
Index of Test Procedures .....	12-16

## **SECTION 13 – ELECTRICAL COMPONENTS**

---

Key Switch .....	13-1
Forward/Reverse Rocker Switch .....	13-3
Tow/Run Switch .....	13-4
Motor Controller Output Regulator (MCOR) .....	13-5
Reverse Buzzer .....	13-6
Solenoid .....	13-6
Onboard Computer (OBC) .....	13-8
Solid State Speed Controller .....	13-10
Charger Receptacle .....	13-11
Receptacle Fuse Link .....	13-13
Battery Warning Light .....	13-13

## **SECTION 14 – BATTERIES**

---

General Information .....	14-1
Common Misconceptions About Batteries .....	14-3
Battery Replacement .....	14-3
Battery Care .....	14-4
Preventive Maintenance .....	14-4
Self-Discharge .....	14-5
Electrolyte Level .....	14-5
Mineral Content .....	14-6
Vibration Damage .....	14-6
Battery Charging .....	14-6
Charger Shuts Off After 16 Hours .....	14-7
Deep-Discharge .....	14-7
Early Excessive Discharging .....	14-7
Incoming AC Service .....	14-7
Fleet Rotation .....	14-7
Numbering Vehicles and Chargers .....	14-7
Battery Troubleshooting Chart .....	14-8

Battery Testing .....	14-9
Battery Charger Test .....	14-9
On-Charge Voltage Test .....	14-9
Hydrometer Test .....	14-9
Discharge Test .....	14-11
Battery Troubleshooting Examples .....	14-13
Battery Storage .....	14-14
Charging a Battery Pack that has Low Voltage .....	14-14

## **SECTION 15 – BATTERY CHARGER**

---

Refer to the appropriate battery charger maintenance and service manual.

## **SECTION 16 – MOTOR**

---

General Information .....	16-1
External Motor Testing .....	16-1
Motor .....	16-3
Motor Component Testing and Inspection .....	16-5
Armature .....	16-5
Field Windings Inspection .....	16-6
Motor Components .....	16-7
Bearing Inspection .....	16-7
Bearing Removal .....	16-9
Bearing Installation .....	16-9
Speed Sensor Magnet Inspection .....	16-9
Speed Sensor Magnet Removal .....	16-9
Speed Sensor Magnet Installation .....	16-9
Reconditioning the Motor .....	16-9
Motor Assembly .....	16-10
Motor Installation .....	16-12
Motor Speed Sensor .....	16-15

## **SECTION 17A – TRANSAXLE (TYPE G)**

---

Transaxle Identification .....	17a-1
Lubrication .....	17a-1
Axle Bearing and Shaft .....	17a-1
Axle Shaft .....	17a-1
Axle Bearing .....	17a-4
Transaxle .....	17a-4
Transaxle Removal .....	17a-5

Transaxle Disassembly, Inspection, and Assembly .....	17a-7
Transaxle Disassembly and Inspection .....	17a-7
Transaxle Assembly .....	17a-9
Transaxle Installation .....	17a-10

## **SECTION 17B – TRANSAXLE (TYPE K)**

---

Transaxle Identification .....	17b-1
Lubrication .....	17b-1
Axle Bearing and Shaft .....	17b-1
Axle Shaft .....	17b-1
Axle Bearing .....	17b-4
Transaxle .....	17b-5
Transaxle Removal .....	17b-5
Transaxle Disassembly, Inspection, and Assembly .....	17b-8
Transaxle Disassembly and Inspection .....	17b-8
Transaxle Assembly .....	17b-11
Shimming the Transaxle .....	17b-13
Transaxle Installation .....	17b-14

## **SECTION 18 – IQ DISPLAY MODULE (IQDM-P) PROGRAMMING**

---

Plugging the Handset into the Vehicle .....	18-1
Program Menu .....	18-2
Speed Setting .....	18-2
Fast Accel .....	18-3
Pedal Up Mode .....	18-3
Speed Cal .....	18-3
Code A, Code B, and Code C .....	18-3

## **SECTION i – INDEX**

---



# SECTION 10 – PERIODIC MAINTENANCE

---

## GENERAL WARNING

---

The following safety statements must be heeded whenever the vehicle is being operated, repaired, or serviced. Service technicians should become familiar with these general safety statements, which can be found throughout this manual. Also, other specific safety statements appear throughout this manual and on the vehicle.

### **DANGER**

- **Battery – Explosive gases! Do not smoke. Keep sparks and flames away from the vehicle and service area. Ventilate when charging or using in an enclosed space. Wear a full face shield and rubber gloves when working on or near batteries.**
- **Battery – Poison! Contains acid! Causes severe burns. Avoid contact with skin, eyes, or clothing. Antidotes:**
  - **External: Flush with water. Call a physician immediately.**
  - **Internal: Drink large quantities of milk or water. Follow with milk of magnesia or vegetable oil. Call a physician immediately.**
  - **Eyes: Flush with water for 15 minutes. Call a physician immediately.**

### **WARNING**

- **Only trained technicians should repair or service the vehicle. Anyone doing even simple repairs or service should have knowledge and experience in electrical and mechanical repair.**
- **Follow the procedures exactly as stated in this manual, and heed all DANGER, WARNING, and CAUTION statements in this manual as well as those affixed to the vehicle.**
- **Improper use of the vehicle or failure to properly maintain it could result in decreased vehicle performance or severe personal injury.**
- **Any modification or change to the vehicle that affects the stability or handling of the vehicle, or increases maximum vehicle speed beyond factory specifications, could result in severe personal injury or death.**
- **Check the vehicle owner’s manual for proper location of all vehicle warning decals and make sure they are in place and are easy to read.**
- **Wear safety glasses or approved eye protection when servicing the vehicle. Wear a full face shield and rubber gloves when working on or near batteries.**
- **Do not wear loose clothing or jewelry such as rings, watches, chains, etc., when servicing vehicle.**
- **Moving parts! Do not attempt to service the vehicle while it is running.**
- **Hot! Do not attempt to service hot motor. Failure to heed this warning could result in severe burns.**
- **Use insulated tools when working near batteries or electrical connections. Use extreme caution to avoid shorting of components or wiring.**
- **Turn key switch OFF and remove key, place Forward/Reverse switch in the NEUTRAL position, and chock the wheels prior to servicing the vehicle.**
- **Place Tow/Run switch in the TOW position before disconnecting or connecting the batteries.**

WARNING CONTINUED ON NEXT PAGE...

- To avoid unintentionally starting the vehicle, place Tow/Run switch in the TOW position, then disconnect the batteries as shown (Figure 10-1, Page 10-2).
- After disconnecting the batteries, wait 90 seconds for the controller capacitors to discharge.
- If wires are removed or replaced, make sure wiring and wire harness is properly routed and secured. Failure to properly route and secure wiring could result in vehicle malfunction, property damage, personal injury, or death.
- Lift only one end of the vehicle at a time. Use a suitable lifting device (chain hoist or hydraulic floor jack) with 1000 lb. (454 kg) minimum lifting capacity. Do not use lifting device to hold vehicle in raised position. Use approved jack stands of proper weight capacity to support the vehicle and chock the wheels that remain on the floor. When not performing a test or service procedure that requires movement of the wheels, lock the brakes.

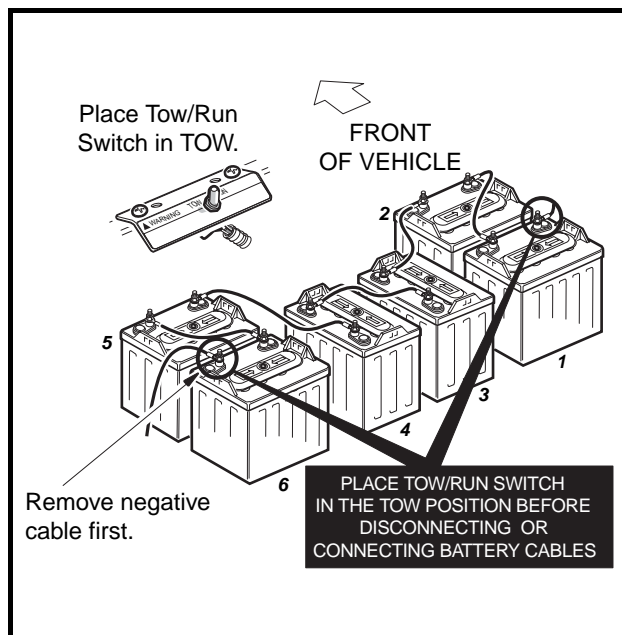


Figure 10-1 Battery Bank for IQ System Vehicle

## GENERAL INFORMATION

To ensure trouble-free vehicle performance, it is very important to follow an established preventive maintenance program. Regular and consistent vehicle maintenance can prevent vehicle downtime and expensive repairs that can result from neglect. Use the Pre-Operation and Daily Safety Checklist on page 10-3 and the Periodic Service Schedule and Periodic Lubrication Schedule to keep the vehicle in proper working condition. **See Periodic Service Schedule on page 10-4. See also Periodic Lubrication Schedule on page 10-6.**

Any vehicle not functioning correctly should be removed from use until it is properly repaired. This will prevent further damage to the vehicle and avoid the possibility of injury due to unsafe conditions.

Contact your local Club Car distributor/dealer to perform all repairs and semiannual and annual periodic service.

## PRE-OPERATION AND DAILY SAFETY CHECKLIST

---

Use the following checklist as a guide to inspect the vehicle. This checklist should be used daily to ensure that the vehicle is in proper working condition and in conjunction with the Periodic Service Schedule on page 10-4. Any problems should be corrected by a Club Car distributor/dealer or a trained technician.

- **General:** All the parts should be in place and properly installed. Be sure that all nuts, bolts, and screws are tight.
- **Safety and information decals:** Check to ensure that all safety and information decals are in place. **See the vehicle owner's manual.**
- **Tires:** Visually inspect tires for wear, damage, and proper inflation on a daily basis. **See Section 2 – Specifications in the appropriate maintenance and service manual.**
- **Batteries:** Check electrolyte to ensure that it is at the proper level. **See Figure 14-6, Section 14, Page 14-5.** Check battery posts. Wires should be tight and free of corrosion and battery should be fully charged.
- **Charger cord, plug, and receptacle:** Visually inspect for cracks, loose connections, and frayed wiring. **See Plug and Receptacle in the vehicle owner's manual.**

## PERFORMANCE INSPECTION

Use the following checklist as a guide to inspect the vehicle and check daily for proper operation. Any problems should be corrected by a Club Car distributor/dealer or a trained technician.

- **Forward/Reverse switch:** Check for proper operation. **See Controls and Indicators in the vehicle owner's manual.**
- **Brakes:** Be sure the brakes function properly. When brake pedal is fully pressed under moderate pressure, it should not go more than halfway to the floor, and vehicle should come to a smooth, straight stop within 14 feet (427 cm). If the pedal goes more than halfway to the floor, or if the vehicle swerves or fails to stop within 14 feet (427 cm), have the brake system checked and adjusted as required. Brake adjustment must be maintained so that the brake pedal cannot be pressed to the floor under any circumstance.
- **Park brake:** When latched, the park brake should lock the wheels and hold the vehicle stationary (on incline of 20% or less). It should release when either the accelerator or brake pedal is pressed.
- **Reverse buzzer:** The reverse buzzer should sound as a warning when the Forward/Reverse switch is in REVERSE.
- **Steering:** The vehicle should be easy to steer and should not have any play in the steering wheel.
- **Accelerator:** With the key switch ON and the Forward/Reverse switch in the FORWARD position, as the accelerator pedal is pressed, the motor should start and the vehicle should accelerate smoothly to full speed. When the pedal is released it should return to the original position and the motor should stop. All Club Car vehicles operate at reduced speed in reverse.
- **General:** Listen for any unusual noises such as squeaks or rattles. Check the vehicle's ride and performance. Have a Club Car distributor/dealer or a trained technician investigate anything unusual.

**Performance Inspection, Continued:**

- **Zero Speed Detect:** With the vehicle parked on level ground and the park brake disengaged, place the Tow/Run switch in the RUN position and attempt to push the vehicle. It should resist rolling (moving at no more than 1 or 2 mph) (1.6 or 3.2 km/h) with the Forward/Reverse switch in any position, and the reverse buzzer should sound.
- **“Pedal Up” Motor Braking (adjustable on IQ System vehicles):** Accelerate the vehicle to full speed and then release the accelerator pedal. Motor braking should quickly and smoothly slow the vehicle to approximately 9 mph. Motor braking will disengage when vehicle slows to 11 mph (17.7 km/h). This feature is adjustable for IQ System vehicles. Contact your local Club Car dealer/distributor to inquire about this adjustable feature.
- **“Pedal Down” Motor Braking:** Accelerate down an incline with the accelerator pedal pressed. When the vehicle reaches approximately 15 mph (24 km/h), motor braking should engage and moderate vehicle speed between 15 and 16 mph (24-26 km/h), depending upon the grade of the hill.

**PERIODIC SERVICE SCHEDULE**** WARNING**

- **Service, repairs, and adjustments must be made per instructions in the appropriate maintenance and service manual and this supplement.**

**NOTE:** *If the vehicle is constantly subjected to heavy use or severe operating conditions, the preventive maintenance procedure should be performed more often than recommended in the periodic service and lubrication schedules.*

*Both the Periodic Service Schedule and the Periodic Lubrication Schedule must be followed to keep vehicle in optimum operating condition.*

PERIODIC SERVICE SCHEDULE		
REGULAR INTERVAL	SERVICE	
Daily service by owner	Batteries	Charge batteries (after each use only).
Weekly service by owner	Batteries	Check electrolyte level. Add water if necessary. <b>See Section 14 – Batteries.</b>
Monthly service by owner or trained technician	Batteries	Wash battery tops and clean terminals with baking soda/water solution.
	Tires	Check air pressure and adjust if necessary. <b>See Section 2 – Specifications in the appropriate maintenance and service manual.</b>
	General vehicle	Wash battery compartment and underside of vehicle.
Periodic Service Schedule continued on next page...		

PERIODIC SERVICE SCHEDULE		
REGULAR INTERVAL	SERVICE	
Semiannual service by trained technician only (every 50 hours of operation or 100 rounds of golf)	Brake system	Check brake shoes; replace if necessary. <b>See Section 6 – Wheel Brake Assemblies in the appropriate maintenance and service manual.</b>
		Lubricate brake slides per Lubrication Schedule. <b>See Section 6 – Wheel Brake Assemblies in the appropriate maintenance and service manual.</b>
		Check brake cables for damage; replace if necessary.
	Electrical wiring and connections	Check for tightness and damage.
	Forward/Reverse switch	Make sure connections are tight.
	Front wheel alignment and camber	Check and adjust as required. <b>See Section 7 – Steering and Front Suspension in the appropriate maintenance and service manual.</b>
	Motor controller output regulator (MCOR)	Check for loose hardware, cracks and other damage.
Annual service by trained technician only (every 100 hours of operation or 200 rounds of golf)	Batteries	If batteries are not performing as expected, see Section 14 – Batteries.

** WARNING**

- If any problems are found during scheduled inspection or service, do not operate the vehicle until repairs are made. Failure to make necessary repairs could result in fire, property damage, severe personal injury, or death.

## PERIODIC LUBRICATION SCHEDULE

See General Warning on page 10-1.

PERIODIC LUBRICATION SCHEDULE			
REGULAR INTERVAL	SERVICE	LUBRICATION POINTS	RECOMMENDED LUBRICANT
Semiannually by owner or trained technician (every 50 hours of operation or 100 rounds of golf)	Brake pedal shaft bearings	1	Dry Moly Lube (CCI P/N 1012151)
	Brake linkage and pivots	2	Dry Moly Lube (CCI P/N 1012151)
	Accelerator pivot rod supports	3	Dry Moly Lube (CCI P/N 1012151)
	Charger receptacle	4	WD 40
	Brake slides	5	Dry Moly Lube (CCI P/N 1012151)
	Front suspension (5 fittings)	6	Chassis Lube (EP NLGI Grade 2)
Annually by trained technician only (every 100 hours of operation or 200 rounds of golf)	Check/fill transaxle to plug level	7	22 oz. (.67 liters) SAE 30 WT. API Class SE, SF, or SG Oil (or higher)
	Inspect front wheel bearings (Repack as necessary)	8	Chassis Lube (EP NLGI Grade 2)

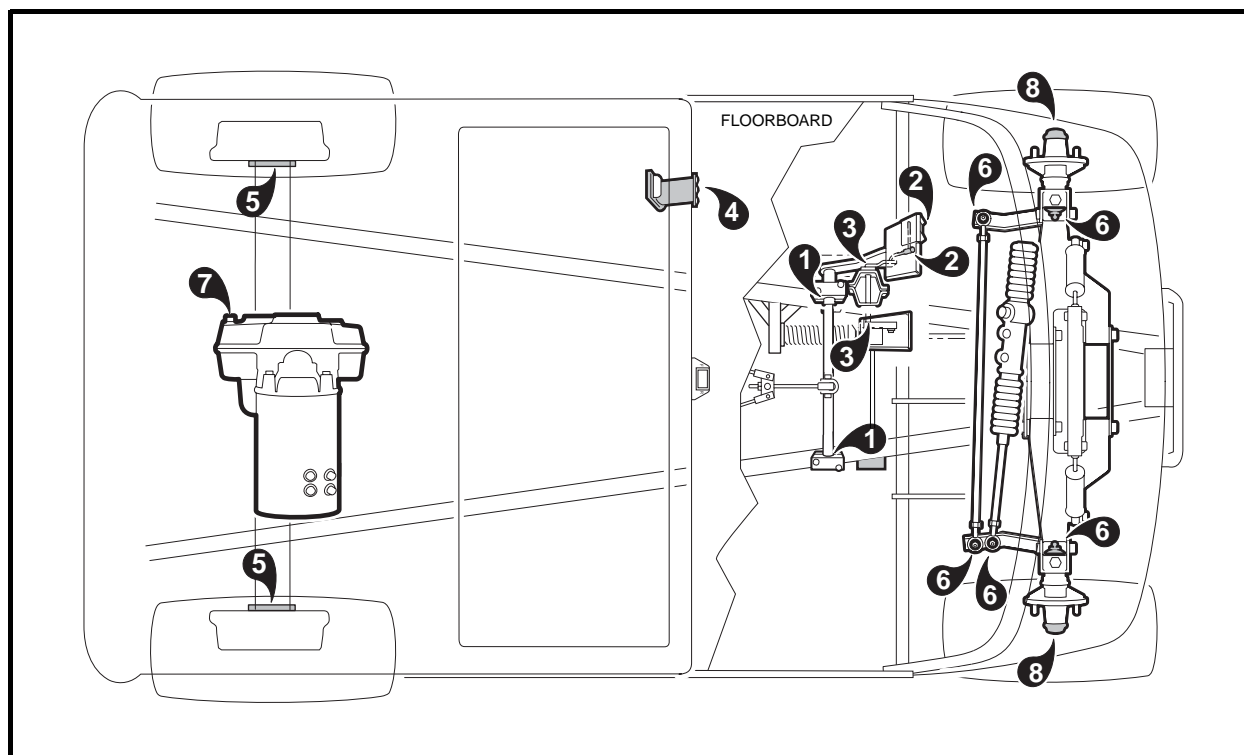


Figure 10-2 Vehicle Lubrication Points

# SECTION 11 – ELECTRICAL SYSTEM AND TESTING

---

## **⚠ DANGER**

- See General Warning, Section 10, Page 10-1.

## **⚠ WARNING**

- See General Warning, Section 10, Page 10-1.

## GENERAL INFORMATION

---

The IQ System vehicle uses a 48-volt electrical system that is powered by six 8-volt lead-acid batteries and includes an onboard computer. The IQ System vehicle uses a shunt-wound 3.2 hp motor and includes several additional features.

- **Shunt-Wound Motor:** The shunt-wound motor, unlike a series motor, is designed so that the speed controller is able to vary the amount of current passing through the field coils independently from the current passing through the armature.
- **Motor Braking:** Under certain conditions a shunt-wound motor also has the ability to act as an electrical brake to slow the vehicle. There are three features of the IQ electrical system which will activate the motor braking function: Zero Speed Detect, Pedal Down Motor Braking, and Pedal Up Motor Braking (adjustable with the IQDM-P handset).
- **Zero Speed Detect:** This prevents the vehicle from rolling away uncontrolled should the driver park on a slope and leave the vehicle without locking the park brake. The vehicle will roll at about 1 mph (1.6 km/h). If the zero speed detect function remains engaged for two seconds or more, a warning buzzer will sound to alert the driver that motor braking has been activated.

## **⚠ WARNING**

- **Zero speed detect may not hold the vehicle on very steep grades. Do not operate vehicle on slopes exceeding 20% grades.**
- **Pedal Down Motor Braking:** This feature helps to control vehicle downhill speed. Motor braking is activated when the vehicle reaches the programmed top speed and holds the vehicle at that speed. Motor braking is automatically disengaged when vehicle speed slows below the programmed top speed.
- **Pedal Up Motor Braking (adjustable):** When vehicle speed is above 11 mph (17.7 km/h), releasing the accelerator pedal will activate motor braking, which slows the vehicle speed. Once vehicle speed slows to below approximately 11 mph (17.7 km/h), with the accelerator pedal still released, motor braking will be deactivated and the vehicle will coast freely. This feature is adjustable. Contact your Club Car dealer/distributor to inquire about this adjustable feature.
- **Regenerative Braking:** When motor braking is activated, the vehicle motor acts as a generator, slowing the vehicle as it creates energy that is used to charge the batteries.

**General Information, Continued:**

- **Tow/Run Switch:** When the Tow/Run switch is in the RUN position, the vehicle will function normally. When the switch is in the TOW position, power to the OBC and controller is shut off, disabling the vehicle operating circuit and zero speed detect, allowing the vehicle to be towed.
- **Motor Protection Circuit:** The operator should never attempt to hold the vehicle on an incline by pressing the accelerator pedal instead of the brake pedal, as motor overheating could result. By reducing the current to the motor during such an occurrence, the motor protection circuit reduces the possibility of motor damage. When this situation arises, a *motor stall fault* is recorded by the speed controller and will be displayed on an IQDM handset in the Diagnostic History menu. **See the IQDM Owner's Manual.**
- **High Pedal Detect:** This function prevents unexpected vehicle movement if the key switch is turned ON after the accelerator is pressed, or the accelerator pedal is pressed when Forward/Reverse switch is used to change the direction of travel. The vehicle will not move until the accelerator is released and pressed again. When this situation arises, a *HPD fault* is recorded by the speed controller and will be displayed on an IQDM handset in the Diagnostic History menu. **See the IQDM Owner's Manual.**
- **Onboard Computer (OBC):** The OBC, 1) monitors battery condition, 2) monitors the number of energy units used by the vehicle, 3) determines the number of energy units required to recharge the batteries and shuts the charger off when this number is reached, 4) determines when to activate regenerative motor braking, 5) locks out vehicle movement while the charger is plugged into the vehicle charger receptacle, 6) stores operating data, which can be read by the Communication Display Module (CDM). **See Communication Display Module (CDM) on page 11-41.**

## ELECTRICAL CIRCUITS

---

**See General Warning, Section 10, Page 10-1.**

The IQ System vehicle has three distinct circuits:

- Control circuit (**Figure 11-2, Page 11-5**)
- Power circuit (**Figure 11-4, Page 11-8**)
- Charge circuit (**Figure 11-5, Page 11-9**).

### CONTROL CIRCUIT

The control circuit consists of three individual circuits:

- Onboard computer circuit (**Figure 11-1, Page 11-3**)
- Solid state speed control circuit (**Figure 11-2, Page 11-5**)
- Tow/Run switch circuit (**Figure 11-3, Page 11-7**).

### Onboard Computer Circuit

The onboard computer (OBC) circuit performs the following functions:

1. Powers down the electrical system during long term storage to reduce battery discharge.
2. Turns the charger on and off during the charge cycle.
3. Locks out the motor speed controller to prevent the vehicle from moving during the charge cycle.
4. Illuminates dash-mounted battery warning light if there is a problem with the batteries or battery charger.
5. Sends a signal from the dash light to the optional Communication Display Module.



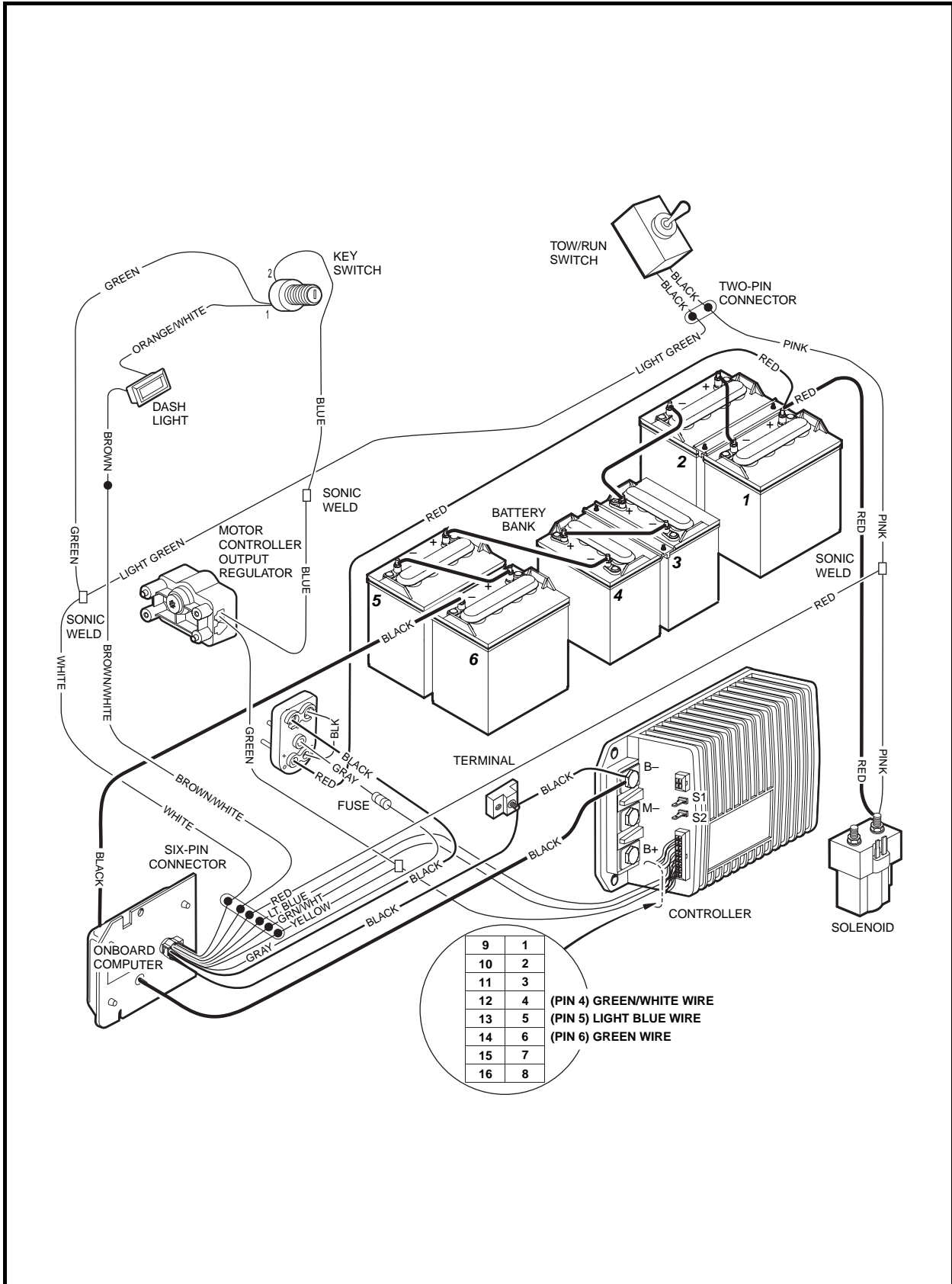


Figure 11-1 Onboard Computer Circuit

### Onboard Computer Circuit, Continued:

The following chart describes the function of each wire of the onboard computer.

OBC WIRE	FUNCTION
Red (18-gauge)	Main power supply for the onboard computer. The vehicle batteries provide +48 volts to the onboard computer.
White (18-gauge)	The Tow/Run switch provides +48 volts to the OBC through the white wire when the switch is in the RUN position. When the Tow/Run switch is in the TOW position, the OBC locks out the speed controller by not sending a +48 volt signal through the light blue OBC wire.
Yellow (18-gauge)	Enables the OBC to power-up (brings the OBC out of sleep mode) when the accelerator pedal is pressed. The MCOR limit switch provides +48 volts to the OBC when the accelerator pedal is pressed.
Brown/White (18-gauge)	Controls the battery warning light by providing a ground to the light through a transistor inside the OBC.
Light Blue (18-gauge)	Solenoid lockout circuit – the OBC provides a +48 volt signal to the speed controller when the battery charger is disconnected.
Green/White (18-gauge)	Reserved for future use. Wire serves no function at this time
Gray (18-gauge)	Provides a ground for the charger relay when the battery charger is connected to the vehicle. Also enables the OBC to power-up (brings the OBC out of sleep mode).
Black (10-gauge) to battery charger receptacle	Battery charging current is controlled by the SCR (silicon-controlled rectifier) inside the onboard computer.
Black (10-gauge) to B– terminal of speed controller	
Black (6-gauge) through onboard computer	Allows the hall-effect sensor inside the OBC to measure the amount of current passing through this wire.

### Battery Warning Light Assembly

The dash-mounted battery warning light performs two functions for the vehicle's electrical system:

**Warning Light:** The battery warning light alerts the operator to any problems with the batteries or charging system. The battery warning light will illuminate under the following conditions:

1. Battery no-load voltage drops below 48 volts.
2. Batteries have discharged more than 75% of rated capacity.
3. AC power is interrupted during the charge cycle (DC plug is still connected).
4. Charge cycle times out at 16 hours.
5. When the DC cord is unplugged before the charge cycle is completed, the battery warning light will illuminate for 10 seconds if the charge is less than 90% complete.

**LED Light:** In addition to the battery warning light, there is an infrared LED in the dash light assembly, which transmits an infrared signal from the OBC. When this signal is received by the optional Communication Display Module, the CDM will display information on the condition of the vehicle and batteries. **See Communication Display Module (CDM) on page 11-41.**

### Solid State Speed Control Circuit

The Solid State Speed Control Circuit performs the following functions:

1. Monitors vehicle ground speed through the motor speed sensor.
2. Regulates vehicle ground speed by using the MCOR to determine accelerator pedal position.

3. Activates the reverse buzzer when the Forward/Reverse rocker switch is in REVERSE.
4. Regulates direction of vehicle movement through the Forward/Reverse switch.
5. Activates the solenoid.

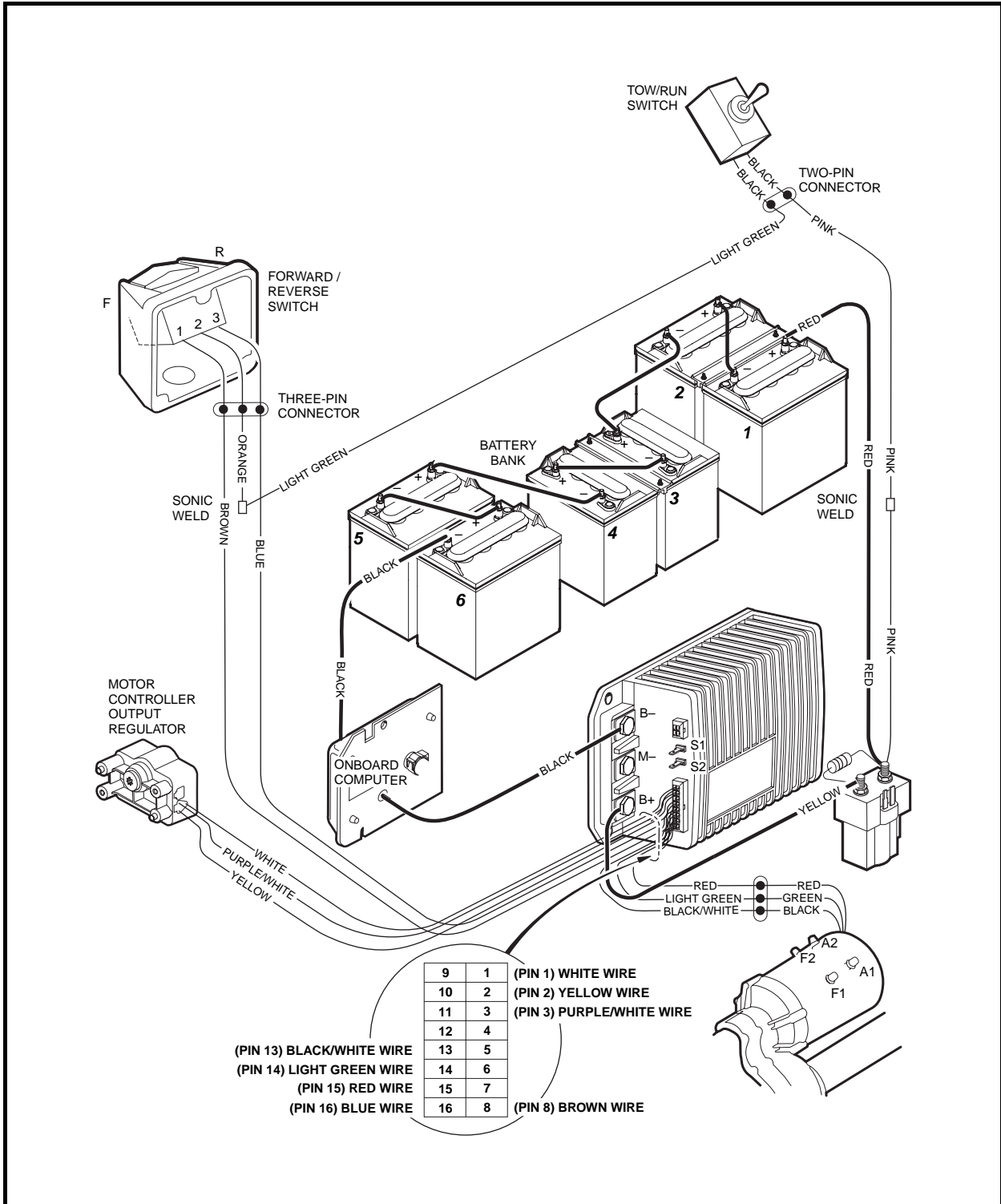


Figure 11-2 Solid State Speed Control Circuit

**Solid State Speed Control Circuit, Continued:**

The following chart describes the function of each wire connected to the 16-pin connector at the speed controller.

SPEED CONTROLLER 16-PIN CONNECTOR WIRE	FUNCTION
Pin 1 – White (18-gauge)	MCOR potentiometer – positive
Pin 2 – Yellow (18-gauge)	MCOR potentiometer – slider
Pin 3 – Purple/White (18-gauge)	MCOR potentiometer – negative
Pin 4 – Green/White (18-gauge)	Reserved for future use. Wire serves no function at this time.
Pin 5 – Light Blue (18-gauge)	Solenoid lockout circuit – the OBC provides a +48 volt signal to the speed controller when the battery charger is disconnected.
Pin 6 – Green (18-gauge)	MCOR limit switch – the limit switch provides +48 volts to the speed controller to turn the speed controller on when the accelerator pedal is pressed.
Pin 7 – Orange/White (18-gauge)	The speed controller provides a ground to the reverse buzzer through a transistor inside the speed controller.
Pin 8 – Brown (18-gauge)	FORWARD input from Forward/Reverse switch – The Forward/Reverse switch sends +48 volts to the speed controller when the switch is in the FORWARD position.
Pin 9 – Gray (18-gauge)	Tow/Run switch input to speed controller – The Tow/Run switch provides +48 volts to the speed controller when placed in the RUN position.
Pin 10 – Tan (18-gauge)	Key switch input – The key switch provides +48 volts to the speed controller when the key switch is in the ON position.
Pin 11 – Open (no wire)	
Pin 12 – Blue/White (18-gauge)	Solenoid coil – The speed controller provides a ground for the solenoid coil after the accelerator pedal is pressed.
Pin 13 – Black/White (18-gauge)	Motor speed sensor – negative
Pin 14 – Light Green (18-gauge)	Motor speed sensor – output
Pin 15 – Red (18-gauge)	Motor speed sensor – positive
Pin 16 – Blue (18-gauge)	REVERSE input from Forward/Reverse switch – The Forward/Reverse switch sends +48 volts to the speed controller when the switch is in the REVERSE position.

**Tow/Run Switch Circuit**

The Tow/Run switch performs the following function when placed in the TOW position:

1. Deactivates the vehicle's control circuit through the onboard computer (OBC) white wire and the light blue and gray wires of the speed controller.

The Tow/Run switch performs the following functions when placed in the RUN position:

1. Activates the vehicle's control circuit through the onboard computer (OBC) white wire and the light blue and gray wires of the speed controller.
2. Provides power to the key switch and the dash-mounted battery warning light.
3. Provides power to the MCOR limit switch through the key switch.
4. Provides power to the OBC yellow wire and the green wire of the speed controller through the key switch and MCOR limit switch.
5. Provides power to the solenoid through the key switch.

- 6. Provides power to the reverse buzzer through the red wire.
- 7. Provides power to the Forward/Reverse switch.

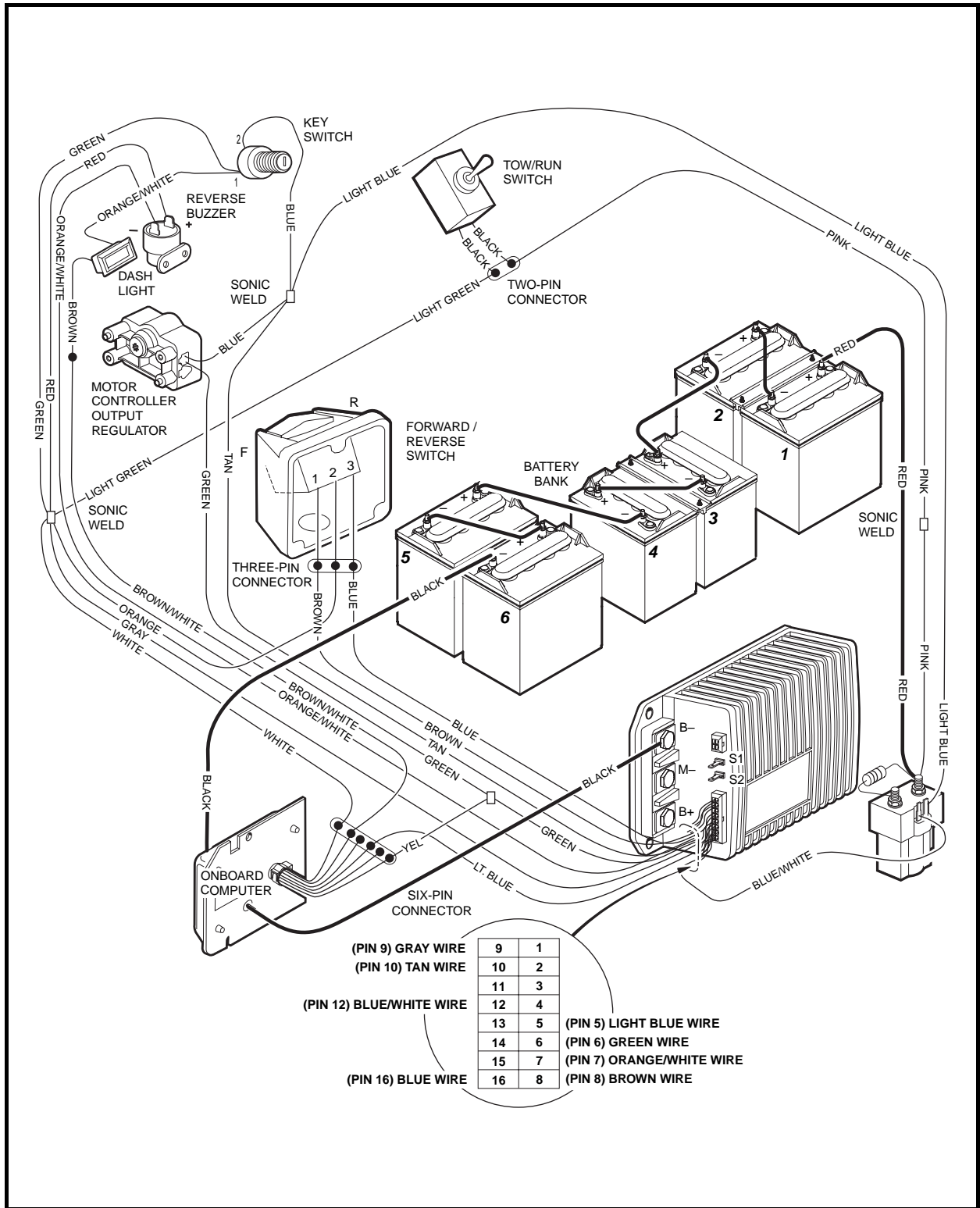


Figure 11-3 Tow/Run Switch Circuit

## POWER CIRCUIT

The function of the power circuit is to supply voltage from the battery pack to the motor. When motor braking is activated, the power circuit will direct motor-generated current to the batteries.

The power circuit consists of:

- Battery pack (six 8-volt batteries)
- Solid state speed controller
- Electric motor
- Solenoid contacts
- All 6-gauge power wires
- Two 10-gauge motor field coil wires

### Electric Motor

The electric motor is explained in detail in another section. **See Section 16 – Motor.**

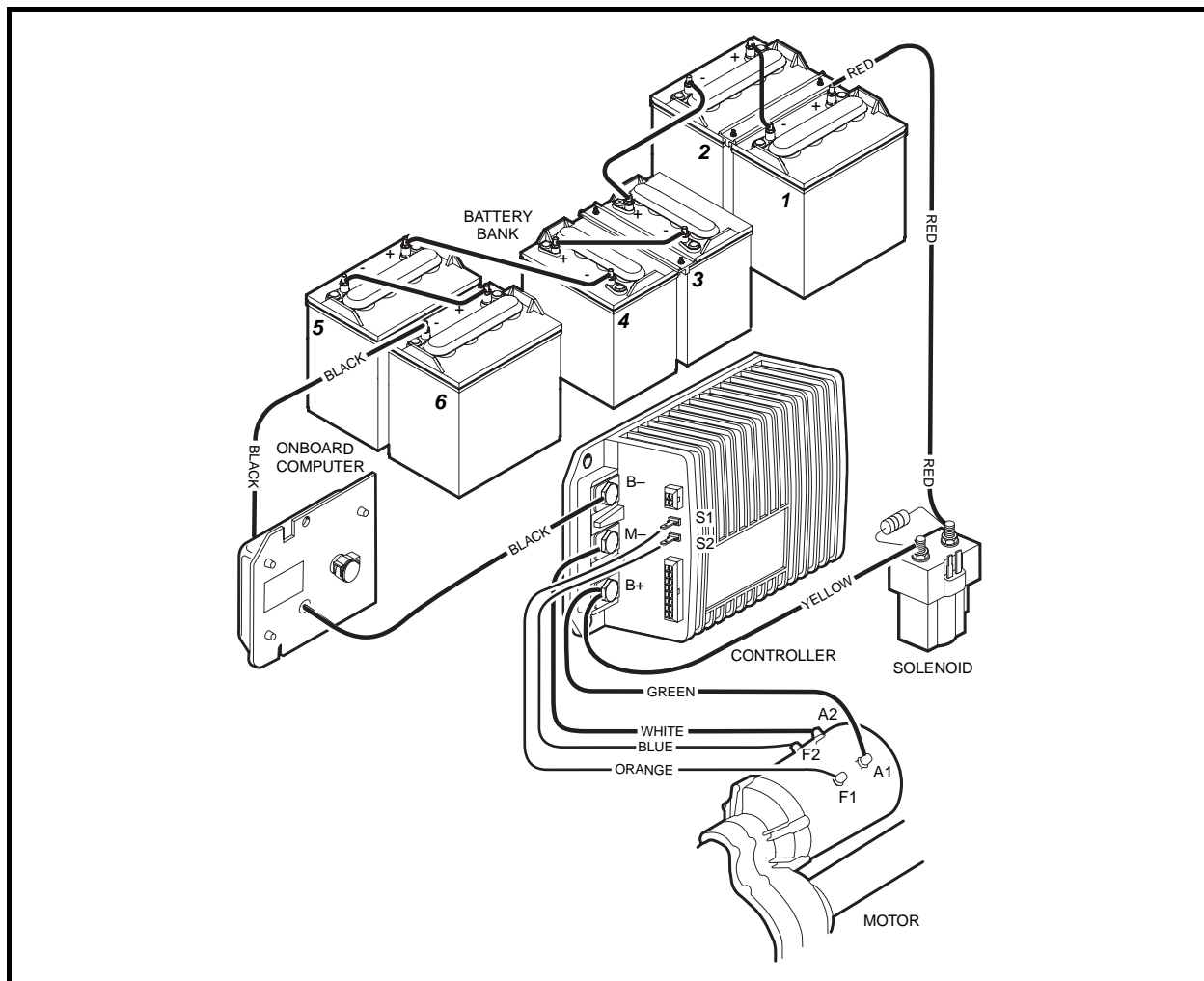


Figure 11-4 Power Circuit

## CHARGE CIRCUIT

The charge circuit consists of:

- Onboard computer
- Battery charger
- DC charger plug
- Charger receptacle
- Receptacle fuse link
- Battery pack

The charge circuit supplies current from the battery charger to the batteries when the DC cord is plugged into the vehicle's charger receptacle. The batteries are explained in detail in another section. **See Section 14 – Batteries.**

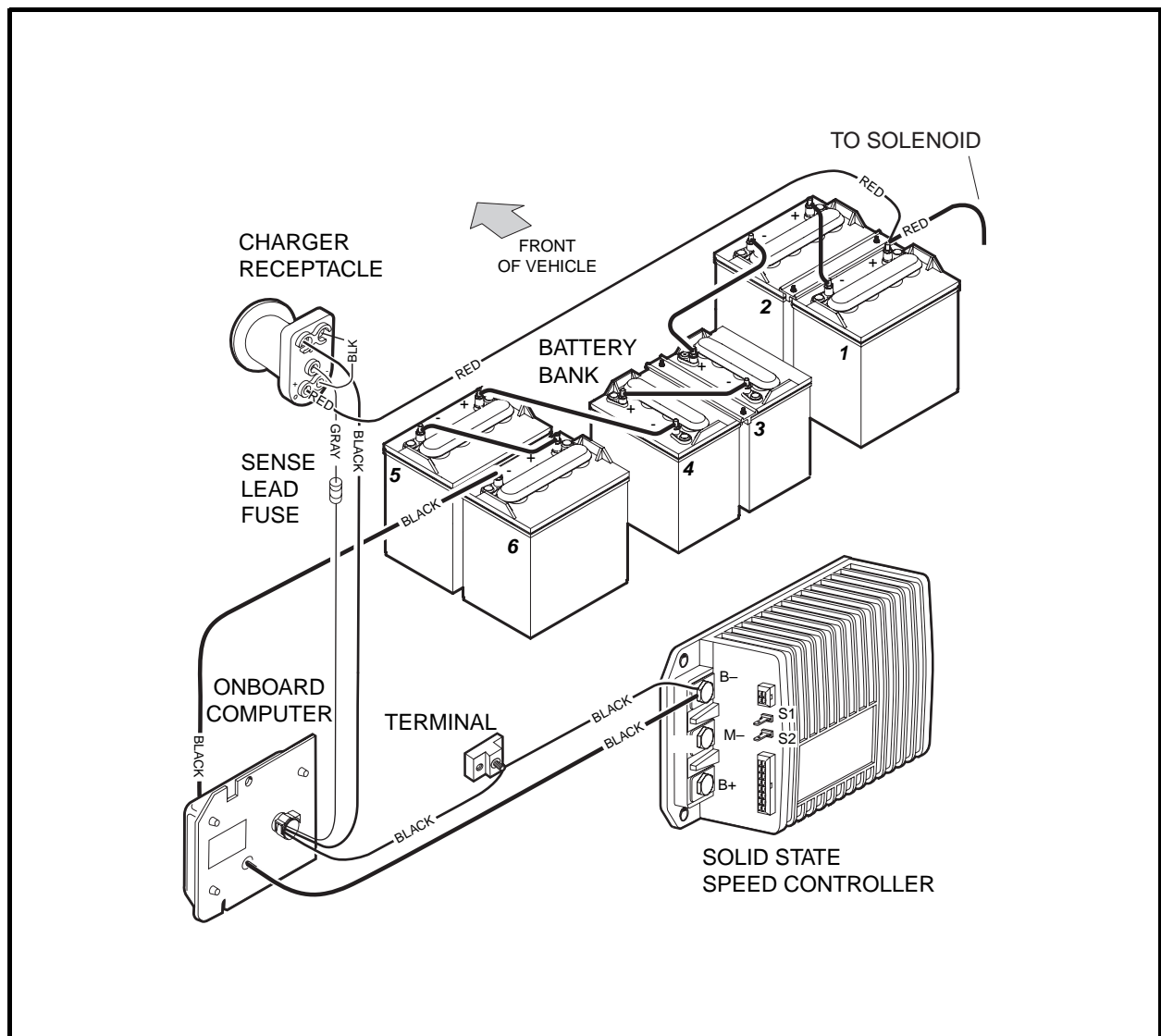


Figure 11-5 Charge Circuit

WIRING DIAGRAM

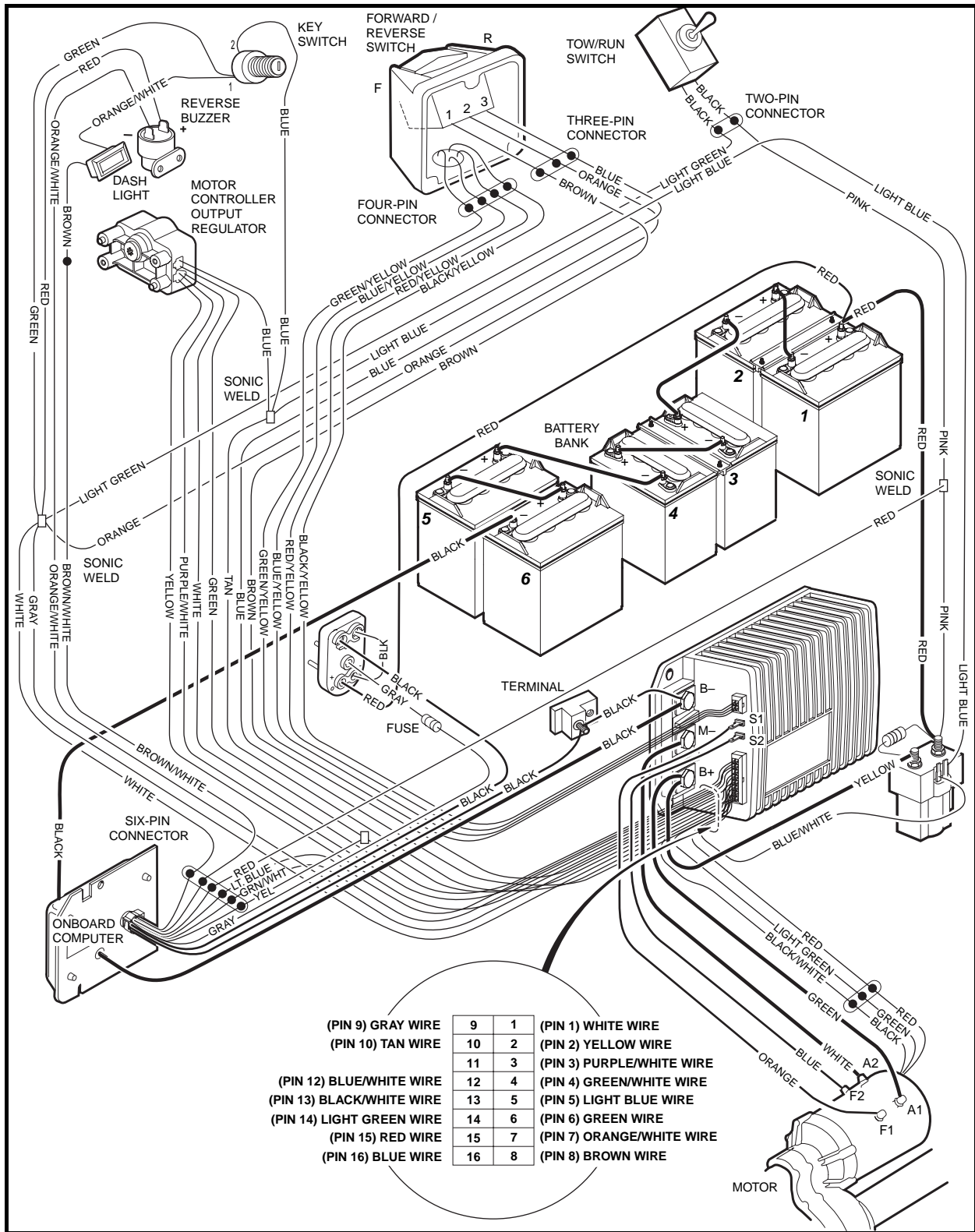


Figure 11-6 Wiring Diagram



## TROUBLESHOOTING

The following troubleshooting guides will be helpful in identifying operating difficulties should they occur. The guides include the symptom, probable cause(s) and suggested checks. The procedures used in making these checks can be found in the referenced sections of this maintenance and service supplement.

### TROUBLESHOOTING THE VEHICLE WITH THE IQDM

Club Car recommends the use of the IQDM handset for troubleshooting vehicles equipped with the IQ electrical system. Troubleshooting Guide 1 is to be used in conjunction with the IQDM handset. Refer to the IQDM Owner's Manual for operating instructions. **See following WARNING.**

#### **▲ WARNING**

- **The vehicle operator should not monitor the IQDM while the vehicle is in motion. A technician can monitor the IQDM while traveling as a passenger in the vehicle. Failure to heed this warning could result in severe personal injury or death.**

In the event that the vehicle is not functioning properly after completing Troubleshooting Guide 1, the technician should proceed to Troubleshooting Guide 2.

If an IQDM handset is unavailable, the technician should proceed to Troubleshooting Guide 2.

### TROUBLESHOOTING GUIDE 1

The following troubleshooting guide is intended for use with an IQDM handset. For IQDM operating instructions, refer to the IQDM Owner's Manual. **See following NOTE.**

**NOTE:** Before troubleshooting the vehicle, check the diagnostic history from the Special Diagnostics Menu. Note any fault codes.

TROUBLESHOOTING GUIDE 1		
SYMPTOM	POSSIBLE CAUSES	CORRECTIVE ACTION
Test Menu – THROTTLE % value does not increase as the accelerator pedal is pressed or Diagnostic Menu – THROTTLE FAULT 1 fault code	Loose or disconnected three-pin connector at the MCOR or broken wire	Repair and/or connect the three-pin connector to the MCOR
	Loose or disconnected 16-pin connector at speed controller or broken wire	Repair and/or connect the 16-pin connector to the speed controller
Test Menu – HEATSINK °C indicates that temperature is above 85 °C (145 °F) or Diagnostic Menu – THERMAL CUTBACK fault code	Failed MCOR	Test Procedure 4 – MCOR Voltage on page 11-20
	Over-adjusted brakes	Section 6 – Wheel Brake Assemblies in the appropriate maintenance and service manual
	Vehicle is over-loaded	Ensure that vehicle is not over-loaded before returning to operation
Troubleshooting Guide continued on next page...		

## TROUBLESHOOTING GUIDE 1

SYMPTOM	POSSIBLE CAUSES	CORRECTIVE ACTION
<b>Test Menu – ARM PWM value does not reach 100% when vehicle is at full speed</b>	Failed MCOR	Test Procedure 4 – MCOR Voltage on page 11-20
	Improper pedal group adjustment	Section 5 – Accelerator and Brake Pedal Group in the appropriate maintenance and service manual
<b>Test Menu – SPEED PULSES menu item indicates that speed pulses are OFF when the vehicle is in motion</b>  <b>or</b>  <b>Diagnostic Menu – SPEED SENSOR fault code</b>	Loose or disconnected motor speed sensor or broken wire	Repair and/or connect the three-pin connector to the motor speed sensor
	Loose or disconnected 16-pin connector at speed controller or broken wire	Repair and/or connect the 16-pin connector to the speed controller
	Failed motor speed sensor	Test Procedure 13 – Motor Speed Sensor on page 11-36
<b>Test Menu – FOOT INPUT menu item indicates that the MCOR internal limit switch is always ON or always OFF.</b>	Loose or disconnected two-pin connector at the MCOR or broken wire	Repair and/or connect the two-pin connector to the MCOR
	Loose or disconnected 16-pin connector at speed controller or broken wire	Repair and/or connect the 16-pin connector to the speed controller
	Failed MCOR	Test Procedure 8 – Key Switch and MCOR Limit Switch Circuit on page 11-23
<b>Test Menu – FORWARD INPUT and/or REVERSE INPUT does not indicate the correct reading</b>  <b>or</b>  <b>Diagnostic Menu – PROC/WIRING fault code</b>	Loose or disconnected Forward/Reverse rocker switch (quick disconnect terminals) or broken wire	Repair and/or connect the quick disconnect terminals to the Forward/Reverse switch
	Loose or disconnected Forward/Reverse rocker switch (three-pin connector) or broken wire	Repair and/or connect the three-pin connector from the Forward/Reverse switch to the wire harness
	Loose or disconnected 16-pin connector at speed controller or broken wire	Repair and/or connect the 16-pin connector to the speed controller
	Failed Forward/Reverse rocker switch	Test Procedure 15 – Forward/Reverse Rocker Switch on page 11-38
<b>Test Menu – MAIN CONT (solenoid) does not indicate ON when the solenoid should be activated.</b>  <b>or</b>  <b>Diagnostic Menu – MAIN CONT DNC (main contactor (solenoid) did not close) fault code</b>	Speed controller logic malfunction	Disconnect the batteries and allow the speed controller capacitors to discharge. <b>See WARNING "To avoid unintentionally starting..." in General Warning, Section 10, Page 10-1.</b> Reconnect the batteries and see if the symptom returns.
	Loose, broken, or disconnected wire(s) at solenoid or B+ speed controller terminal	Repair and/or connect the loose or disconnected wire(s)
	Loose or disconnected 16-pin connector at speed controller or broken wire	Repair and/or connect the 16-pin connector to the speed controller
	Failed solenoid	Replace solenoid. <b>See Solenoid Removal, Section 13, Page 13-7.</b>
<b>Test Menu – KEY INPUT does not indicate ON when key switch is in the ON position</b>	Loose or disconnected wires at key switch terminals or broken wire	Repair and/or connect the quick disconnect terminals to the Forward/Reverse switch
	Loose or disconnected 16-pin connector at speed controller or broken wire	Repair and/or connect the 16-pin connector to the speed controller
	Failed key switch	Test Procedure 8 – Key Switch and MCOR Limit Switch Circuit on page 11-23
<b>Troubleshooting Guide continued on next page...</b>		

TROUBLESHOOTING GUIDE 1		
SYMPTOM	POSSIBLE CAUSES	CORRECTIVE ACTION
Diagnostic Menu – THROTTLE FAULT 1 fault code	Loose or disconnected three-pin connector at the MCOR or broken wire	Repair and/or connect the three-pin connector to the MCOR
	Loose or disconnected 16-pin connector at speed controller or broken wire	Repair and/or connect the 16-pin connector to the speed controller
Diagnostic Menu – THROTTLE FAULT 1 fault code, continued	Failed MCOR	Test Procedure 4 – MCOR Voltage on page 11-20
Diagnostic Menu – HW FAILSAFE (Hardware Failsafe) fault code	Armature drive FET's (field-effect transistors) inside speed controller have failed	Replace the speed controller. <b>See Speed Controller Removal, Section 13, Page 13-10.</b>
	Speed controller logic malfunction	Disconnect the batteries and allow the speed controller capacitors to discharge. <b>See WARNING "To avoid unintentionally starting..." in General Warning, Section 10, Page 10-1.</b> Reconnect the batteries and see if the symptom returns.
Diagnostic Menu – MAIN WELDED (main solenoid contacts welded) fault code	solenoid contacts have failed closed	Replace solenoid. <b>See Solenoid Removal, Section 13, Page 13-7.</b>
Diagnostic Menu – MAIN DRIVER ON or MAIN DRIVER OFF fault code	Speed controller logic malfunction	Disconnect the batteries and allow the speed controller capacitors to discharge. <b>See WARNING "To avoid unintentionally starting..." in General Warning, Section 10, Page 10-1.</b> Reconnect the batteries and see if the symptom returns.
	Failure of the FET that controls the solenoid coil	Replace the speed controller. <b>See Speed Controller Removal, Section 13, Page 13-10.</b>
Diagnostic Menu – MAIN COIL FAULT fault code or Diagnostic Menu – MAIN DROPOUT fault code	Solenoid coil has failed in an open condition	Replace solenoid. <b>See Solenoid Removal, Section 13, Page 13-7.</b>
Diagnostic Menu – FIELD MISSING fault code	Loose or disconnected motor field coil wires at motor or speed controller or broken wire	Repair and/or connect the field coil wires
	Failure of the motor field windings	Section 16 – Motor
	Failure of the FET's that control field current	Replace the speed controller. <b>See Speed Controller Removal, Section 13, Page 13-10.</b>
Diagnostic Menu – HPD (high pedal detect) fault code	Operator error	Train operators to fully remove foot from accelerator pedal before turning key switch to the ON position or changing the selected direction with the Forward/Reverse switch
Diagnostic Menu – LOW BATTERY fault code	Batteries require charging	Place batteries on battery charger and allow them to fully charge
	Improperly maintained or failed batteries	Section 14 – Batteries
Troubleshooting Guide continued on next page...		

**TROUBLESHOOTING GUIDE 1**

SYMPTOM	POSSIBLE CAUSES	CORRECTIVE ACTION
Diagnostic Menu – MOTOR STALL fault code	Operator error	Train operators to use the brake to hold the vehicle on a hill, rather than holding the vehicle on a hill using the accelerator pedal
Diagnostic Menu – OPEN ARMATURE fault code	Loose or disconnected motor armature wires at motor or speed controller or broken wire	Repair and/or connect the motor armature wires
	Failure of the motor armature or brushes	Section 16 – Motor
	Failure of the FET's that control armature current	Replace the speed controller. <b>See Speed Controller Removal, Section 13, Page 13-10.</b>

**TROUBLESHOOTING GUIDE 2****TROUBLESHOOTING GUIDE 2**

SYMPTOM	POSSIBLE CAUSES	CORRECTIVE ACTION
Vehicle does not operate	Batteries – Batteries discharged	Charge batteries
	Batteries – Battery connections	Check vehicle wiring. <b>See Wiring Diagram on page 11-10.</b>
	Battery charger is connected to the vehicle – Solenoid lockout feature has disabled the vehicle	Disconnect the battery charger from the vehicle
	Onboard computer failure	Test Procedure 2 – Onboard Computer Solenoid Lockout Circuit on page 11-17
	Key switch and MCOR limit switch circuit	Check for loose or disconnected wires at key switch and MCOR
	Failed key switch	Test Procedure 8 – Key Switch and MCOR Limit Switch Circuit on page 11-23
	Failed MCOR	Test Procedure 8 – Key Switch and MCOR Limit Switch Circuit on page 11-23. See also Test Procedure 4 – MCOR Voltage on page 11-20.
	Forward/Reverse rocker switch	Test Procedure 15 – Forward/Reverse Rocker Switch on page 11-38
	Solenoid – loose wires	Test Procedure 3 – Solenoid Activating Coil and Diode on page 11-18
	Solenoid – failed coil	Test Procedure 3 – Solenoid Activating Coil and Diode on page 11-18
	Solenoid – failed solenoid diode	Test Procedure 3 – Solenoid Activating Coil and Diode on page 11-18
	Speed controller thermal cutback	Allow controller to cool and ensure that vehicle is not over-loaded before returning to operation
	16-pin connector at speed controller	Check for loose or disconnected wires at the 16-pin connector. <b>See also Test Procedure 9 – 16-Pin Connector on page 11-25.</b>
Troubleshooting Guide continued on next page...		

<b>TROUBLESHOOTING GUIDE 2</b>		
<b>SYMPTOM</b>	<b>POSSIBLE CAUSES</b>	<b>CORRECTIVE ACTION</b>
<b>Vehicle does not operate, continued</b>	High pedal detect	Cycle accelerator pedal
	Motor stall	Cycle accelerator pedal
	Motor Failure	Section 16 – Motor
	Speed controller failure	Replace speed controller. <b>See Speed Controller Removal, Section 13, Page 13-10.</b>
<b>Vehicle runs slowly</b>	Speed sensor disconnected or failed	Test Procedure 13 – Motor Speed Sensor on page 11-36
	Incorrect speed setting	To change the programmed top speed of the vehicle, an IQDM-P handset must be used
	Wiring – improperly wired	Check vehicle wiring. <b>See Wiring Diagram on page 11-10.</b>
	Batteries – Batteries discharged	Charge batteries
	MCOR malfunction	Test Procedure 4 – MCOR Voltage on page 11-20
	Motor – loose wires	Inspect and tighten all wire connections at the motor
	Failed motor	Replace motor. <b>See Motor Removal, Section 16, Page 16-3.</b>
	Vehicle is over-loaded	Ensure that vehicle is not over-loaded before returning to operation
	Speed controller failure	Replace speed controller. <b>See Speed Controller Removal, Section 13, Page 13-10.</b>
	Brakes – improperly adjusted	<b>See Section 6 – Wheel Brake Assemblies in the appropriate maintenance and service manual.</b>
	Tires – under-inflated or flat tires	<b>See Section 8 – Wheels and Tires in the appropriate maintenance and service manual.</b>
<b>Vehicle operates, but motor braking function does not</b>	Wiring – improperly wired	Check vehicle wiring. <b>See Wiring Diagram on page 11-10.</b>
	Speed sensor disconnected or failed	Test Procedure 13 – Motor Speed Sensor on page 11-36
<b>Vehicle will run in forward, but not in reverse or will run in reverse but not forward</b>	Forward/Reverse rocker switch – improperly wired	Test Procedure 15 – Forward/Reverse Rocker Switch on page 11-38
	Motor – improperly wired	Check motor wiring. <b>See Wiring Diagram on page 11-10.</b>
	Speed controller – improperly wired or failed speed controller FET	Check vehicle wiring. <b>See Wiring Diagram on page 11-10.</b>
<b>Vehicle operates, but battery charger does not charge batteries</b>	Onboard computer – gray wire or fuse	Test Procedure 11 – Onboard Computer Gray Wire and Fuse on page 11-35
	Battery charger connections – loose wires at receptacle or batteries	Check wire connections and tighten if necessary.
	Battery charger	Refer to the appropriate battery charger maintenance and service manual

## TEST PROCEDURES

---

Using the following procedures, the entire IQ electrical system can be tested without major disassembly of the vehicle.

### **⚠ WARNING**

- **If wires are removed or replaced, make sure wiring and wire harness is properly routed and secured. Failure to properly route and secure wiring could result in vehicle malfunction, property damage, personal injury, or death.**

## INDEX OF TEST PROCEDURES

1. Batteries / Voltage Check
2. Onboard Computer Solenoid Lockout Circuit
3. Solenoid Activating Coil and Diode
4. MCOR Voltage
5. A1 and A2 Motor Voltage
6. Tow/Run Switch
7. Battery Pack Voltage (Under Load)
8. Key Switch and MCOR Limit Switch Circuit
9. 16-Pin Connector
10. Onboard Computer Silicon-Controlled Rectifier (SCR) Circuit
11. Onboard Computer Gray Wire and Fuse
12. Voltage at Charger Receptacle Red Wire Socket
13. Motor Speed Sensor
14. Solenoid Continuity
15. Forward/Reverse Rocker Switch
16. Reverse Buzzer
17. Rebooting the Onboard Computer
18. Battery Warning Light

## TEST PROCEDURE 1 – BATTERIES / VOLTAGE CHECK

**See General Warning, Section 10, Page 10-1.**

**NOTE:** *The batteries must be properly maintained and fully charged in order to perform the following test procedures. Battery maintenance procedures, including watering information and allowable mineral content, can be found in Section 14 of this manual. See **Battery Care, Section 14, Page 14-4.***

The battery voltage can be displayed with the IQDM handset. If an IQDM handset is not available, proceed to Batteries / Voltage Check without the IQDM Handset on page 11-17.

## Batteries / Voltage Check with the IQDM Handset

1. Connect the IQDM to the vehicle.
2. Access the Test menu and select BATT VOLTAGE by using the SCROLL DISPLAY buttons. The IQDM should indicate at least 48 volts with the batteries fully charged. If not, check for loose battery connections or a battery installed in reverse polarity. Refer to Section 14 – Batteries, for further details on battery testing.

## Batteries / Voltage Check without the IQDM Handset

1. With batteries connected and using a multimeter set to 200 volts DC, place red (+) probe on the positive (+) post of battery no. 1 and the black (–) probe on the negative (–) post of battery no. 6 (**Figure 11-7, Page 11-17**). The multimeter should indicate at least 48 volts with the batteries fully charged. If not, check for loose battery connections or a battery installed in reverse polarity. Refer to Section 14 – Batteries, for further details on battery testing.

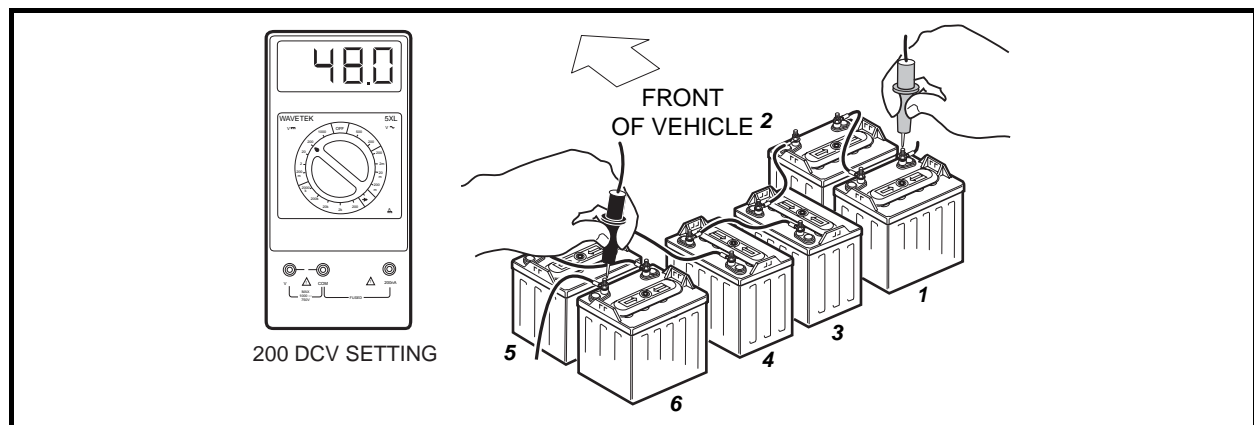


Figure 11-7 Battery Test

## TEST PROCEDURE 2 – ONBOARD COMPUTER SOLENOID LOCKOUT CIRCUIT

### See General Warning, Section 10, Page 10-1.

The solenoid lockout circuit disables the vehicle when the battery charger is plugged into the vehicle. Use the following procedure to test the solenoid lockout circuit:

1. With batteries connected, place the Tow/Run switch in the RUN position.
2. Using a multimeter set to 200 volts DC, place black (–) probe on battery no. 6 negative post and red (+) probe (with insulation-piercing probe) on the blue onboard computer wire (at a point between the OBC and the six-pin connector). The reading should be approximately 48-50 volts (full battery voltage). If the reading is not 48-50 volts, proceed to step 3. If the reading is 48-50 volts, proceed to Test Procedure 3 – Solenoid Activating Coil and Diode on page 11-18.
3. Place insulation-piercing probe on the light blue 18-gauge wire at a point between OBC six-pin connector and main wire harness. If reading is 48-50 volts, check the wire terminal connectors inside six-pin connector at OBC six-pin connector. Make sure pins are properly aligned inside housing. Make sure wire colors match and are connected to the correct terminals.

**Batteries / Voltage Check without the IQDM Handset, Continued:**

4. If reading is zero volts, plug the charger DC cord into the vehicle charger receptacle. If the dash light illuminates for 10 seconds, the OBC is now powered-up. Unplug the DC cord; the reading at the OBC blue wire should be approximately 48-50 volts. If the vehicle now operates normally, the DC cord has powered up the electrical system. The electrical system should also power-up when the accelerator pedal is pressed. To check the accelerator pedal function, see Test Procedure 4 – MCOR Voltage on page 11-20.
5. If the dash light illuminates for 10 seconds and the vehicle does not operate:
  - 5.1. Using a multimeter set to 200 volts DC, place black (–) probe on battery number 6 and place red (+) probe (with insulation-piercing probe) on blue 18-gauge wire at OBC six-pin connector.
  - 5.2. With Tow/Run switch in the RUN position, the voltage reading should be approximately 48 volts.
6. If the dash light does not illuminate and the vehicle does not operate, check the OBC activation circuit.
  - 6.1. Using a multimeter set to 200 volts DC, place the black (–) probe on the battery no. 6 negative post and place the red (+) probe (with insulation-piercing probe) on the red 18-gauge wire located on the OBC side of the six-pin connector. The reading should be approximately 48 volts. If the reading is incorrect, test the Tow/Run switch and connecting wires. **See Test Procedure 6 – Tow/Run Switch on page 11-22.**
  - 6.2. Using a multimeter set to 200 volts DC, place the black (–) probe on the battery no. 6 negative post and place the red (+) probe (with insulation-piercing probe) on the red 18-gauge wire (harness side of six-pin connector). Multimeter should indicate 48 volts. If voltage is correct, check connections in the six-pin connector. If connections are correct, OBC activation circuit has failed. Replace OBC.

**TEST PROCEDURE 3 – SOLENOID ACTIVATING COIL AND DIODE**

See General Warning, Section 10, Page 10-1.

1. Disconnect the battery cables as instructed. **See WARNING "To avoid unintentionally starting..." in General Warning, Section 10, Page 10-1.**
2. Remove the two small wire terminals from the solenoid.
3. The diode must be checked and found to be functioning correctly before the activating coil resistance can be accurately measured. The diode can only be tested using a continuity test light (CCI P/N 1011273).
  - 3.1. Place the probe end of the tester on the small terminal of the solenoid marked positive (+) and place the alligator clip of the tester on the wire on the other small activating coil terminal (**Figure 11-8, Page 11-18**). The tester should illuminate, indicating continuity.
  - 3.2. Reverse the positions of the probe and the alligator clip (**Figure 11-9, Page 11-18**). The tester should not illuminate. If any other reading is obtained, the diode must be replaced. If the diode is functioning correctly, proceed to step 5.

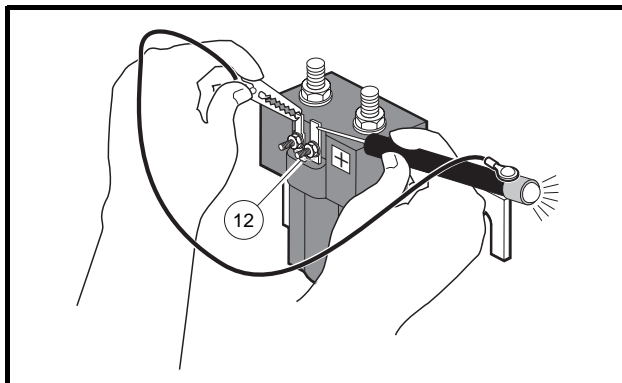


Figure 11-8 Diode Test – Probe Position One

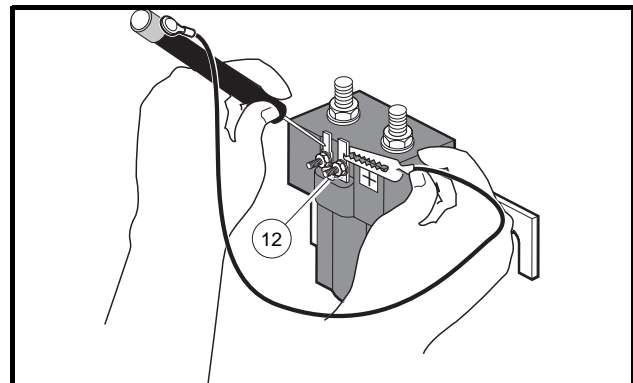


Figure 11-9 Diode Test – Probe Position Two



4. To remove the diode, carefully clip the two leads where they attach to the solenoid terminals (**Figure 11-10, Page 11-19** and **Figure 11-11, Page 11-19**). See following **NOTE**.

**NOTE:** The diode must be functioning correctly before checking the resistance of the activating coil. In the case of a failed diode, the diode must be removed before the coil resistance can be checked.

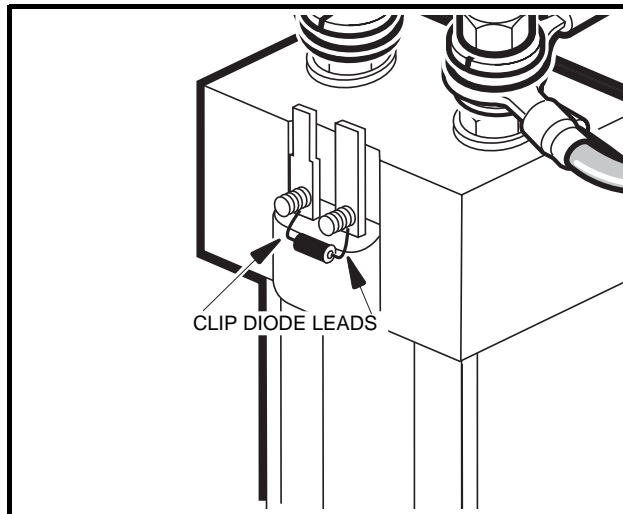


Figure 11-10 Diode Removal

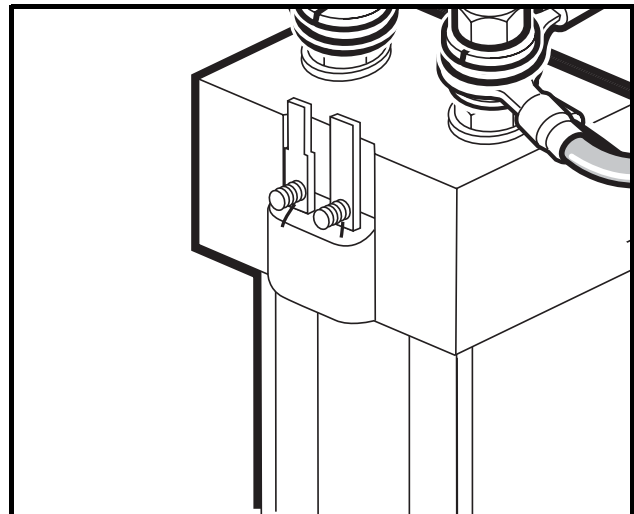


Figure 11-11 Solenoid with Diode Removed

5. Place red (+) probe of the multimeter on the positive (+) solenoid terminal. Place the black (-) probe on the other small solenoid terminal. A reading of 180 to 190 ohms should be obtained (**Figure 11-12, Page 11-19**). If not, replace the solenoid.

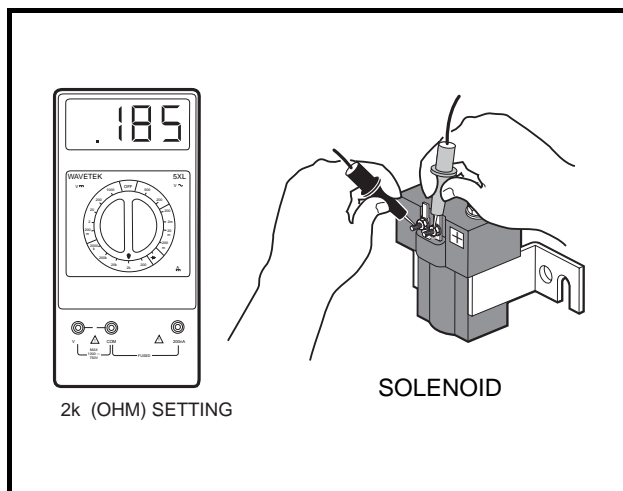


Figure 11-12 Activating Coil Test

6. If a failed diode was removed, replace the diode by installing a new diode assembly (CCI P/N 1014948), making sure that the red ring terminal of the replacement diode is connected to the positive (+) solenoid terminal.

## TEST PROCEDURE 4 – MCOR VOLTAGE

### See General Warning, Section 10, Page 10-1.

The accelerator position, which is proportional to the MCOR voltage, can be displayed with the IQDM handset. If an IQDM handset is not available, proceed to MCOR Voltage Test without the IQDM Handset on page 11-20.

### MCOR Voltage Test with the IQDM Handset

1. Place chocks at the front wheels and lift the rear of the vehicle with a chain hoist or floor jack. Position jack stands under the frame crossmember between the spring mount and side stringer, just forward of each rear wheel. **See following NOTE.**

**NOTE:** The key switch should be placed in the OFF position and left in the OFF position for the duration of this test.

2. Connect the IQDM to the vehicle as described in the IQDM Owner's Manual.
3. Access the Test menu and select THROTTLE % by using the SCROLL DISPLAY buttons.
4. The IQDM should indicate 0 % with the pedal not pressed. While monitoring the IQDM display screen, slowly press the accelerator pedal. As the pedal is pressed, the IQDM should indicate a rise from 0 % (pedal not pressed) to 100 % (pedal fully pressed).
5. If the MCOR does not operate as described in step 4, proceed to MCOR Voltage Test without the IQDM Handset on page 11-20.

### MCOR Voltage Test without the IQDM Handset

1. Place chocks at the front wheels and lift the rear of the vehicle with a chain hoist or floor jack. Position jack stands under the frame crossmember between the spring mount and side stringer, just forward of each rear wheel. **See following NOTE.**

**NOTE:** The key switch should be placed in the OFF position and left in the OFF position for the duration of this test.

2. With the batteries connected, place Tow/Run switch in RUN. Using a multimeter set to 200 volts DC, place red (+) probe on battery no. 1 positive post and place black (-) probe (with insulation-piercing probe) on the purple/white wire at a point close to the three-pin connector at the MCOR. The reading should be approximately 48-50 volts (full battery voltage).
3. If reading is zero volts, check the purple/white wire continuity from the three-pin connector at the MCOR to the 16-pin connector at the speed controller. Check terminal positions in three-pin connector at the MCOR and the 16-pin connector. If all of the continuity readings are correct and the connectors are wired correctly, replace the speed controller.
4. With multimeter set to 20 volts DC, place the black (-) probe on battery no. 6 negative post and the red (+) probe (with insulation-piercing probe) on the white wire at a point close to the three-pin connector at the MCOR. The reading should be approximately 4.65 volts.
5. If reading is zero volts, check the white wire continuity from the three-pin connector at the MCOR to the 16-pin connector at the speed controller. Check terminal positions in three-pin connector at the MCOR and the 16-pin connector. If all of the continuity readings are correct and the connectors are wired correctly, replace the speed controller.

**MCOR Voltage Test without the IQDM Handset, Continued:**

6. With multimeter set to 20 volts DC, place the black (–) probe on battery no. 6 negative post and the red (+) probe (with insulation-piercing probe) on the no. 18 yellow wire at a point close to three-pin connector at the MCOR. The reading should be approximately 0.32 volts with the pedal up. Slowly press the accelerator pedal and note the readings on the multimeter. As the pedal is pressed, the reading should increase until it reaches 4.65 volts when the pedal is fully pressed.
7. If reading does not increase as the pedal is pressed, replace the MCOR.
8. If the reading is not approximately 4.60 volts with the pedal fully pressed, the vehicle will not operate at rated top speed. Check the MCOR resistance.
  - 8.1. Disconnect the battery cables as instructed. **See WARNING "To avoid unintentionally starting..." in General Warning, Section 10, Page 10-1.**
  - 8.2. Disconnect the 16-pin connector at the speed controller.
  - 8.3. Using a multimeter set for 20k ohms, connect the red (+) probe of the multimeter to the yellow wire at the MCOR three-pin connector with an insulation piercing probe. Connect black (–) probe to the purple/white wire with an insulation-piercing probe.
  - 8.4. With the accelerator pedal fully up (not pressed), the multimeter should read approximately 1k ohms.
  - 8.5. Slowly press the accelerator pedal while monitoring the multimeter. The resistance should rise as the pedal is pressed. When the pedal is all the way to the floor, the multimeter should indicate between 5.67k ohms and 7.43k ohms.
  - 8.6. Using a multimeter set for 20k ohms, connect the red (+) probe of the multimeter to the yellow wire at the MCOR three-pin connector with an insulation piercing probe. Connect black (–) probe to the white wire with an insulation-piercing probe.
  - 8.7. With the accelerator pedal fully up (not pressed), the multimeter should indicate between 5.67k ohms and 7.43k ohms.
  - 8.8. Slowly press the accelerator pedal while monitoring the multimeter. The resistance should drop as the pedal is pressed. When the pedal is all the way to the floor, the multimeter should indicate approximately 1k ohms.
  - 8.9. If the MCOR does not operate as described, replace the MCOR.

**TEST PROCEDURE 5 – A1 AND A2 MOTOR VOLTAGE****See General Warning, Section 10, Page 10-1.**

1. Place chocks at the front wheels and lift the rear of the vehicle with a chain hoist or floor jack. Position jack stands under the frame crossmember between the spring mount and side stringer, just forward of each rear wheel.
2. With the batteries connected and using a multimeter set to 200 volts DC, place the black (–) probe on the A2 motor terminal (white wire) and connect the red (+) probe to the A1 (green wire) motor terminal.
3. With Tow/Run switch in the RUN position, place the Forward/Reverse switch in the FORWARD position, turn key switch to the ON position and slowly press accelerator pedal.
4. As the accelerator pedal is pressed, the voltage reading should increase from approximately 5 volts RMS when the MCOR limit switch closes, to approximately 48 volts RMS with the accelerator pedal fully pressed.
  - 4.1. If there is no voltage reading, check the MCOR. **See Test Procedure 4 – MCOR Voltage on page 11-20.** Also check the continuity of the large posts of the solenoid. **See Test Procedure 14 – Solenoid Continuity on page 11-37.**
  - 4.2. Disconnect the battery cables as instructed. **See WARNING "To avoid unintentionally starting..." in General Warning, Section 10, Page 10-1.**

- 4.3. Check continuity on A1 and A2 motor terminal posts and continuity of the F1 and F2 motor terminal posts. Also, check continuity of all motor wires. **See Section 16 – Motor.**

## TEST PROCEDURE 6 – TOW/RUN SWITCH

**See General Warning, Section 10, Page 10-1.**

### Tow/Run Switch Test with the IQDM Handset

1. With the Tow/Run switch in the RUN position, connect the IQDM to the vehicle as described in the IQDM Owner's Manual.
2. Immediately after the IQDM is connected to the vehicle, the screen should display a copyright notice and the IQDM model number.
3. If the IQDM display screen is blank, drive the vehicle a short distance to activate the onboard computer.
4. If the vehicle will not operate, proceed to **Tow/Run Switch Test without the IQDM Handset.**
5. If the IQDM display screen begins to work after the vehicle has been driven, turn the key switch to the OFF position and proceed to step 6; otherwise, perform the following procedure, Tow/Run Switch Test without the IQDM Handset.
6. With the IQDM still connected to the vehicle, place the Tow/Run Switch in the TOW position and wait 90 seconds.
7. If the IQDM display screen goes blank after 90 seconds, the Tow/Run switch and connecting wires are operating correctly.
8. If the IQDM display screen is still active after 90 seconds, the switch has failed closed. Replace the Tow/Run switch. **See Tow/Run Switch Removal, Section 13, Page 13-4.**

### Tow/Run Switch Test without the IQDM Handset

1. With the batteries connected and using a multimeter set on 200 volts DC, connect the black (–) probe to the negative post of battery no. 6 and connect red (+) probe (with insulation-piercing probe) on the light green wire close to the two-pin connector on the Tow/Run switch.
2. With the Tow/Run switch in the RUN position, the reading should be approximately 48-50 volts. With the switch in the TOW position, the reading should be below approximately 5 volts.
3. If the reading is above 5 volts with the switch in the TOW position, replace the switch.
4. If the reading is below 5 volts with switch in the RUN position, check continuity of the two-pin connector and the pink 18-gauge wire from the large post of the solenoid to the two-pin connector at the Tow/Run switch.
5. If the two-pin connector and pink wire continuity readings are correct, replace the Tow/Run switch.
6. If replacement of the Tow/Run switch does not correct the problem, a failed diode on Pin 9 could be the cause. **See Test Procedure 9F – Pin 9 on page 11-32.**

## TEST PROCEDURE 7 – BATTERY PACK VOLTAGE (UNDER LOAD)

**See General Warning, Section 10, Page 10-1.**

1. Before proceeding with this test procedure, the batteries must be connected and fully charged. Using a 36 to 48-volt battery discharge machine (CCI P/N 101831901), connect the positive (+) lead of the discharge machine to battery no. 1 positive post and connect the negative (–) lead to battery no. 6 negative post. Record the voltage reading from discharge machine.
2. Turn the discharge machine on and record the voltage reading of battery pack while under load.
3. A fully charged set of batteries in good condition should read between 46-49 volts while under load.

4. A reading of 32-46 volts indicates discharged or failed batteries. Each battery should be checked with a multimeter while under load.
5. A reading of 32 volts or less will not activate discharge machine. If the voltage of the batteries is below 32 volts, the batteries are deeply discharged or have failed.
6. Recording the battery pack voltage reading while under load provides a more accurate diagnosis of the condition of the batteries. When the discharge machine is ON, it places the battery pack under load and many times can help determine if one or more batteries in the set have failed. Testing battery voltage while the batteries are not under load will not always indicate the true condition of the batteries. For more information about the batteries, refer to Section 14 – Batteries.

## TEST PROCEDURE 8 – KEY SWITCH AND MCOR LIMIT SWITCH CIRCUIT

See General Warning, Section 10, Page 10-1.

### Key Switch and MCOR Limit Switch Circuit Test with the IQDM Handset

1. Place chocks at the front wheels and lift the rear of the vehicle with a chain hoist or floor jack. Position jack stands under the frame crossmember between the spring mount and side stringer, just forward of each rear wheel.
2. Turn the key switch to the OFF position and place the Forward/Reverse switch in the NEUTRAL position.
3. Connect the IQDM to the vehicle as described in the IQDM Owner's Manual.
4. Test the key switch.
  - 4.1. Access the Test menu and select KEY INPUT by using the SCROLL DISPLAY buttons. The IQDM should indicate OFF when the key switch is in the OFF position.
  - 4.2. While monitoring the IQDM display screen, turn the key switch to the ON position. The IQDM should indicate ON.
  - 4.3. If the IQDM does not indicate that KEY INPUT is ON when the key switch is in the ON position, proceed to the following procedure, Key Switch and MCOR Limit Switch Circuit Test without the IQDM Handset. If the key switch functions as described, proceed to the following step. **See following NOTE.**

**NOTE:** The key switch *MUST* function properly in order to test the MCOR limit switch with the IQDM handset.

5. Test the MCOR limit switch.
  - 5.1. Select FOOT INPUT on the Test menu by using the SCROLL DISPLAY buttons on the IQDM.
  - 5.2. The IQDM should indicate that FOOT INPUT is OFF when the accelerator pedal is not pressed, regardless of the key switch position.
  - 5.3. With the key switch in the ON position, press the accelerator pedal. The IQDM should indicate that FOOT INPUT is ON when the accelerator pedal is pressed.
6. If any reading is obtained that is not described in steps 4 and 5, perform the following steps:
  - 6.1. Check the pedal group for proper adjustment. **See Section 5 – Accelerator and Brake Pedal Group in the appropriate maintenance and service manual.**
  - 6.2. Check the wiring of the key switch and MCOR. **See Wiring Diagram on page 11-10.**
  - 6.3. Check the continuity of the key switch wires and the MCOR limit switch wires.
7. If the problem was not found, proceed to the following procedure, Key Switch and MCOR Limit Switch Circuit Test without the IQDM Handset on page 11-24.

## Key Switch and MCOR Limit Switch Circuit Test without the IQDM Handset

1. Disconnect the battery cables as instructed. **See WARNING "To avoid unintentionally starting..." in General Warning, Section 10, Page 10-1.**
2. Place chocks at the front wheels and lift the rear of the vehicle with a chain hoist or floor jack. Position jack stands under the frame crossmember between the spring mount and side stringer, just forward of each rear wheel.
3. Turn the key switch to the OFF position and place the Forward/Reverse switch in the NEUTRAL position.
4. Test the key switch.
  - 4.1. Remove the center dash panel. **See step 2 of Key Switch Removal, Section 13, Page 13-1.**
  - 4.2. Using a multimeter set to 200 ohms, place the red (+) probe on the key switch terminal with the blue wire. Place the black (–) probe on the other key switch terminal.
  - 4.3. With the key switch in the OFF position, the multimeter should indicate that continuity is not present.
  - 4.4. With the key switch in the ON position, the multimeter should indicate that continuity is present.
  - 4.5. If any other reading is obtained, replace the key switch. **See Key Switch Removal, Section 13, Page 13-1.**
  - 4.6. If the key switch operates as described in the previous steps, install the dash panel in the reverse order of removal and proceed to the following step.
5. Test the MCOR limit switch. **See following NOTE.**

**NOTE:** *Make sure that the key switch is operating correctly and that the key switch and dash panel are properly installed before proceeding.*

- 5.1. With batteries connected and using a multimeter set to 200 volts DC, place the black (–) probe on the battery no. 6 negative post and place the red (+) probe (with insulation-peircing probe) on the green wire close to the two-pin connector on the MCOR.
- 5.2. With Tow/Run switch in the RUN position, key switch in the ON position, and Forward/Reverse rocker switch in the NEUTRAL position, the voltage reading should be zero volts. When the accelerator pedal is pressed, the voltage reading should be approximately 48 volts (full battery voltage).
- 5.3. If the voltage reading is 48 volts when the accelerator pedal is not pressed, check the pedal group for proper adjustment. **See Section 5 – Accelerator and Brake Pedal Group in the appropriate maintenance and service manual.**
- 5.4. If the voltage reading is zero volts when the accelerator pedal is pressed, check the limit switch circuit using the following test procedures.
  - 5.4.1. Using a multimeter set to 200 volts DC, place black (–) probe on battery no. 6 negative post and the place red (+) probe (with insulation-peircing probe) on the blue wire where it connects to the MCOR. With the key switch ON, the reading should be approximately 48 volts (full battery voltage).
  - 5.4.2. If the reading is zero volts, check the continuity of the blue wire that goes from the key switch to the MCOR.
  - 5.4.3. If the reading is approximately 48 volts, proceed to the following step.
  - 5.4.4. Using a multimeter set to 200 volts DC, place the black (–) probe on the battery no. 6 negative post and place the red (+) probe (with insulation-peircing probe) on the green wire where it connects to the MCOR. With the Tow/Run switch in the RUN position, the key switch ON, the Forward/Reverse rocker switch in NEUTRAL and the accelerator pedal pressed, the reading should be approximately 48 volts (full battery voltage).
  - 5.4.5. If the reading is zero volts, test the continuity of the MCOR limit switch and the green wire. If the limit switch does not pass the continuity test, replace the MCOR. **See MCOR Removal, Section 13, Page 13-5.**

## TEST PROCEDURE 9 – 16-PIN CONNECTOR

See General Warning, Section 10, Page 10-1.

1. Disconnect the battery cables as instructed. See **WARNING "To avoid unintentionally starting..."** in **General Warning, Section 10, Page 10-1.**
2. Disconnect the 16-pin connector from the speed controller. Inspect terminal ends inside plug to ensure they are in position and seated in plug housing. If any terminals look like they are not pushed all the way into the connector, gently push the terminals until they are firmly seated in the 16-pin connector. After each terminal has been pushed into the housing, gently pull on the wire to ensure it is locked into place.
3. Check wires in the plug to make sure none are broken at the terminal pin crimp. Repair or replace as required.
4. Check the wire colors of each wire and make sure that the colors for each pin position match the wire colors in the wiring diagram. See **Wiring Diagram on page 11-10.**
5. When connecting the 16-pin connector to the controller, push plug into controller receptacle with enough force to lock plug into place. An audible click will be heard when plug is properly seated to the controller.

A procedure is provided for testing each of the wires in the 16-pin connector. Refer to the following chart for the appropriate procedure for each pin in the 16-pin connector.

If the results of any of the referenced procedures are different from those described in the procedure, check the continuity of the wires in the wire harness and test the connected components with the appropriate test procedures. See **Index of Test Procedures on page 11-16.**

SPEED CONTROLLER 16-PIN CONNECTOR WIRE	TEST PROCEDURE
Pin 1 – White (18-gauge)	Test Procedure 9A – Pins 1, 2, and 3 on page 11-26
Pin 2 – Yellow (18-gauge)	
Pin 3 – Purple/White (18-gauge)	
Pin 4 – Green/White (18-gauge)	Reserved for future use. Wire serves no function at this time
Pin 5 – Light Blue (18-gauge)	Test Procedure 9B – Pin 5 on page 11-27
Pin 6 – Green (18-gauge)	Test Procedure 9C – Pin 6 on page 11-28
Pin 7 – Orange/White (18-gauge)	Test Procedure 9D – Pin 7 on page 11-29
Pin 8 – Brown (18-gauge)	Test Procedure 9E – Pins 8 and 16 on page 11-30
Pin 9 – Gray (18-gauge)	Test Procedure 9F – Pin 9 on page 11-32
Pin 10 – Tan (18-gauge)	Test Procedure 9G – Pin 10 on page 11-33
Pin 11 – Open (no wire)	
Pin 12 – Blue/White (18-gauge)	Test Procedure 9H – Pin 12 on page 11-34
Pin 13 – Black/White (18-gauge)	Test continuity of each wire and perform Test Procedure 13 – Motor Speed Sensor on page 11-36
Pin 14 – Light Green (18-gauge)	
Pin 15 – Red (18-gauge)	
Pin 16 – Blue (18-gauge)	Test Procedure 9E – Pins 8 and 16 on page 11-30

## Test Procedure 9A – Pins 1, 2, and 3

### See General Warning, Section 10, Page 10-1.

Pins 1, 2, and 3 in the 16-pin connector provide a connection point from the MCOR potentiometer to the speed controller.

1. Disconnect the battery cables as instructed. **See WARNING "To avoid unintentionally starting..." in General Warning, Section 10, Page 10-1.**
2. Place chocks at the front wheels and lift the rear of the vehicle with a chain hoist or floor jack. Position jack stands under the frame crossmember between the spring mount and side stringer, just forward of each rear wheel.
3. Disconnect the 16-pin connector at the speed controller.
4. Using a multimeter set for 20k ohms, insert the red (+) probe of the multimeter into pin 2 (yellow wire) of the 16-pin connector. **See following CAUTION.** Insert the black (–) probe into pin 3 (purple/white wire) of the 16-pin connector (**Figure 11-13, Page 11-26**).

### **⚠ CAUTION**

- Do not fully insert probes into the 16-pin plug. Doing so can result in a poor connection.
5. With the accelerator pedal fully up (not pressed), the multimeter should read approximately 1k ohms.
  6. Slowly press the accelerator pedal while monitoring the multimeter. The resistance should rise as the pedal is pressed. When the pedal is all the way to the floor, the multimeter should indicate between 5.67k ohms and 7.43k ohms.
  7. Using a multimeter set for 20k ohms, insert the red (+) probe of the multimeter into pin 2 (yellow wire) at the 16-pin connector. Connect the black (–) probe into pin 1 (white wire). **See previous CAUTION.**
  8. With the accelerator pedal fully up (not pressed), the multimeter should indicate between 5.67k ohms and 7.43k ohms.
  9. Slowly press the accelerator pedal while monitoring the multimeter. The resistance should drop as the pedal is pressed. When the pedal is all the way to the floor, the multimeter should indicate approximately 1k ohms.
  10. If any other reading is observed, check the continuity of the wires in the wire harness.

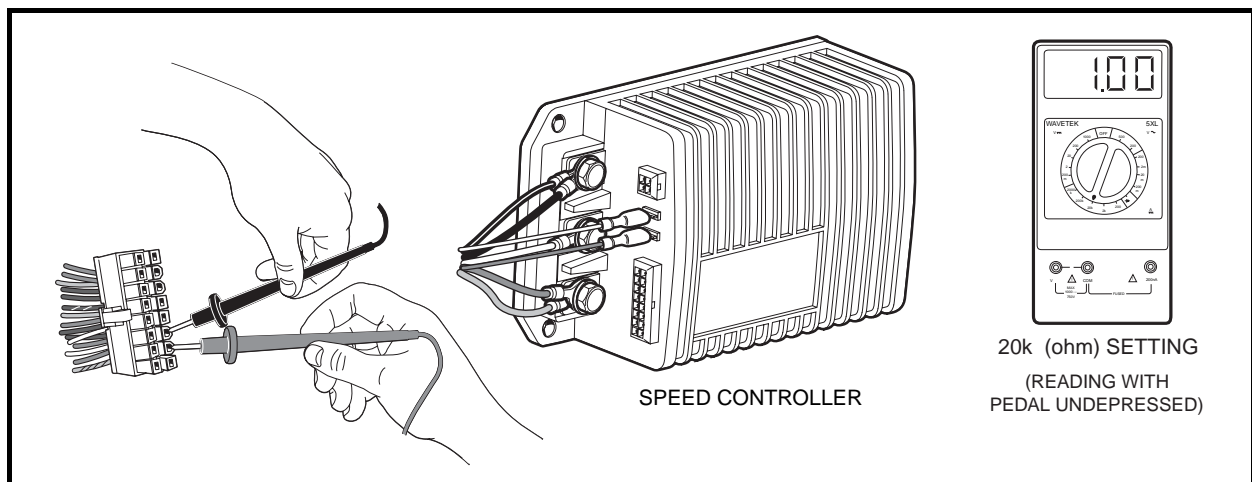


Figure 11-13 Pins 1, 2, and 3 Test



## Test Procedure 9B – Pin 5

### See General Warning, Section 10, Page 10-1.

Pin 5 in the 16-pin connector provides a connection point for the solenoid lockout circuit from the onboard computer to the speed controller.

1. Disconnect the battery cables as instructed. See **WARNING "To avoid unintentionally starting..."** in **General Warning, Section 10, Page 10-1**.
2. Place chocks at the front wheels and lift the rear of the vehicle with a chain hoist or floor jack. Position jack stands under the frame crossmember between the spring mount and side stringer, just forward of each rear wheel.
3. Disconnect the 16-pin connector at the speed controller.
4. Using a multimeter set for 200 volts DC, insert the red (+) probe of the multimeter into pin 5 (light blue wire) of the 16-pin connector. See following **CAUTION**. Using an alligator clip, connect the black (-) probe to the B- terminal of the speed controller (**Figure 11-14, Page 11-27**).

### **CAUTION**

- Do not fully insert probes into the 16-pin plug. Doing so can result in a poor connection.

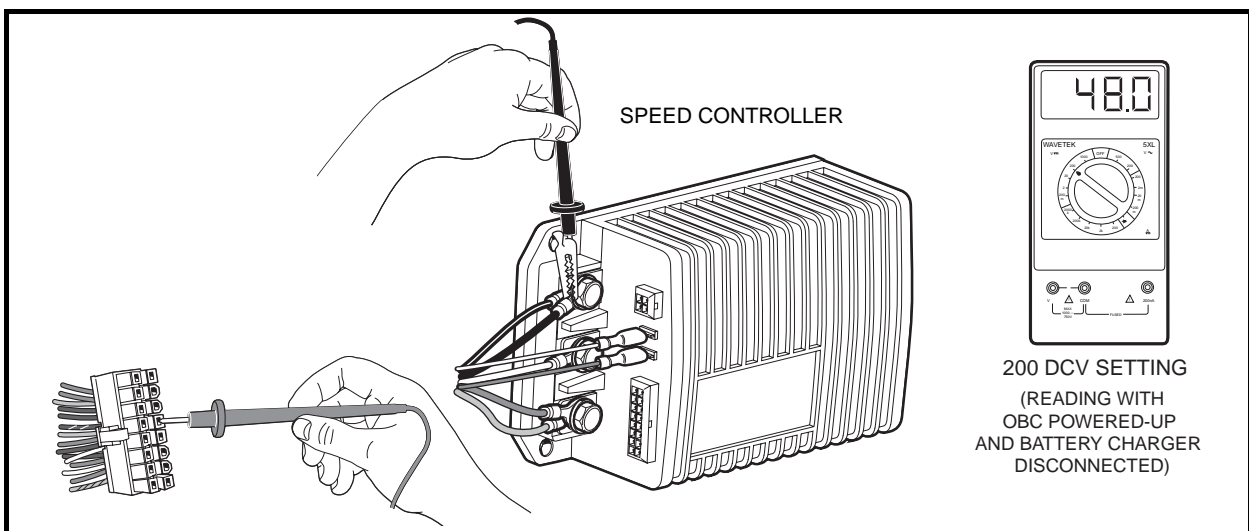


Figure 11-14 Pin 5 Test

5. Place the Tow/Run switch in the TOW position and connect the battery cables, positive (+) cable first. Tighten battery terminals to 110 in-lb (12.4 N·m).
6. Place the Tow/Run switch in the RUN position.
7. The multimeter should indicate zero volts DC at this time.
8. While monitoring the multimeter, plug the battery charger into the vehicle charger receptacle.
9. After a short delay, the onboard computer should power-up (come out of sleep mode), charger relay should click, and the ammeter on the charger should indicate that the vehicle batteries are being charged.
10. The multimeter should indicate zero volts DC while the charger is connected to the vehicle.

**Key Switch and MCOR Limit Switch Circuit Test without the IQDM Handset, Continued:**

11. While observing the multimeter, disconnect the DC plug from the vehicle charger receptacle.
12. The multimeter should indicate full battery voltage when the charger is not connected to the vehicle.
13. If any other reading is obtained, check the following items:
  - Continuity of the wires in the wire harness
  - Onboard computer for proper operation. **See Test Procedure 11 – Onboard Computer Gray Wire and Fuse on page 11-35.**
  - Tow/Run switch for proper operation. **See Test Procedure 6 – Tow/Run Switch on page 11-22.**

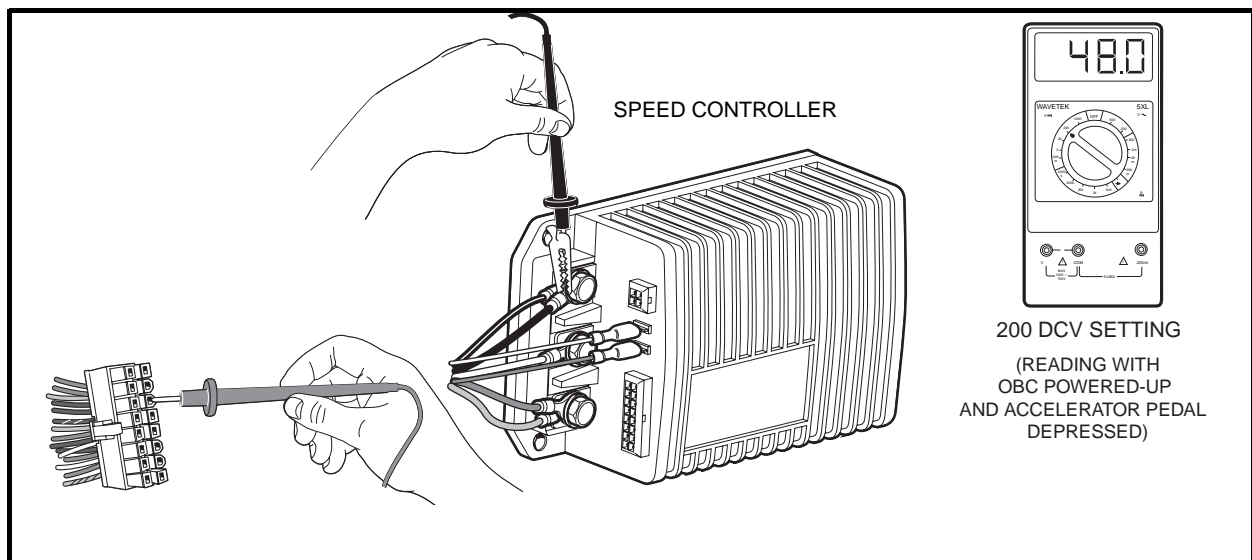
**Test Procedure 9C – Pin 6****See General Warning, Section 10, Page 10-1.**

Pin 6 in the 16-pin connector provides a connection point for the MCOR limit switch to the speed controller.

1. Disconnect the battery cables as instructed. **See WARNING "To avoid unintentionally starting..." in General Warning, Section 10, Page 10-1.**
2. Place chocks at the front wheels and lift the rear of the vehicle with a chain hoist or floor jack. Position jack stands under the frame crossmember between the spring mount and side stringer, just forward of each rear wheel.
3. Disconnect the 16-pin connector at the speed controller.
4. Using a multimeter set for 200 volts DC, insert the red (+) probe of the multimeter into pin 6 (green wire) of the 16-pin connector. **See following CAUTION.** Using an alligator clip, connect the black (-) probe to the B- terminal of the speed controller (**Figure 11-15, Page 11-28**).

**⚠ CAUTION**

- Do not fully insert probes into the 16-pin plug. Doing so can result in a poor connection.



**Figure 11-15 Pin 6 Test**

5. Place the Tow/Run switch in the TOW position and connect the battery cables, positive (+) cable first. Tighten battery terminals to 110 in-lb (12.4 N·m).
6. Place the Tow/Run switch in the RUN position, key switch in the ON position, and Forward/Reverse switch in the FORWARD position.
7. The multimeter should indicate zero volts DC at this time.
8. While monitoring the multimeter, slowly press the accelerator pedal and hold the pedal at approximately 20% of full travel.
9. After a short delay, the onboard computer should power-up (come out of sleep mode).
10. The multimeter should indicate full battery voltage (approximately 48 volts) when the accelerator pedal is pressed.
11. While observing the multimeter, release the accelerator pedal.
12. The multimeter should indicate zero volts when the accelerator pedal is not pressed.
13. If any other reading is obtained, check the following items:
  - Continuity of the wires in the wire harness
  - Onboard computer for proper operation. **See Test Procedure 11 – Onboard Computer Gray Wire and Fuse on page 11-35.**
  - Tow/Run switch for proper operation. **See Test Procedure 6 – Tow/Run Switch on page 11-22.**
  - Key switch and MCOR limit switch for proper operation. **See Test Procedure 8 – Key Switch and MCOR Limit Switch Circuit on page 11-23.**
  - Ensure that the pedal group is adjusted correctly. **See Section 5 – Accelerator and Brake Pedal Group in the appropriate maintenance and service manual.**

## Test Procedure 9D – Pin 7

### See General Warning, Section 10, Page 10-1.

Pin 7 in the 16-pin connector provides a connection point for the reverse buzzer to the speed controller.

1. Disconnect the battery cables as instructed. **See WARNING "To avoid unintentionally starting..." in General Warning, Section 10, Page 10-1.**
2. Place chocks at the front wheels and lift the rear of the vehicle with a chain hoist or floor jack. Position jack stands under the frame crossmember between the spring mount and side stringer, just forward of each rear wheel.
3. Disconnect the 16-pin connector at the speed controller.
4. Place a jumper wire with an alligator clip between the B– terminal of the speed controller (use alligator clip for this connection) and pin 7 (orange/white wire) of the 16-pin connector (**Figure 11-16, Page 11-30**). **See following CAUTION.**

### **⚠ CAUTION**

- **Do not fully insert probes into the 16-pin plug. Doing so can result in a poor connection.**
5. Place the Tow/Run switch in the TOW position and connect the battery cables, positive (+) cable first. Tighten battery terminals to 110 in-lb (12.4 N·m).
  6. Place the Tow/Run switch in the RUN position.
  7. The reverse buzzer should sound when the Tow/Run switch is in the RUN position.

**Key Switch and MCOR Limit Switch Circuit Test without the IQDM Handset, Continued:**

8. If any other activity is observed, check the following items:
  - Continuity of the wires in the wire harness
  - Reverse buzzer for proper operation. **See Test Procedure 16 – Reverse Buzzer on page 11-39.**
  - Tow/Run switch for proper operation. **See Test Procedure 6 – Tow/Run Switch on page 11-22.**

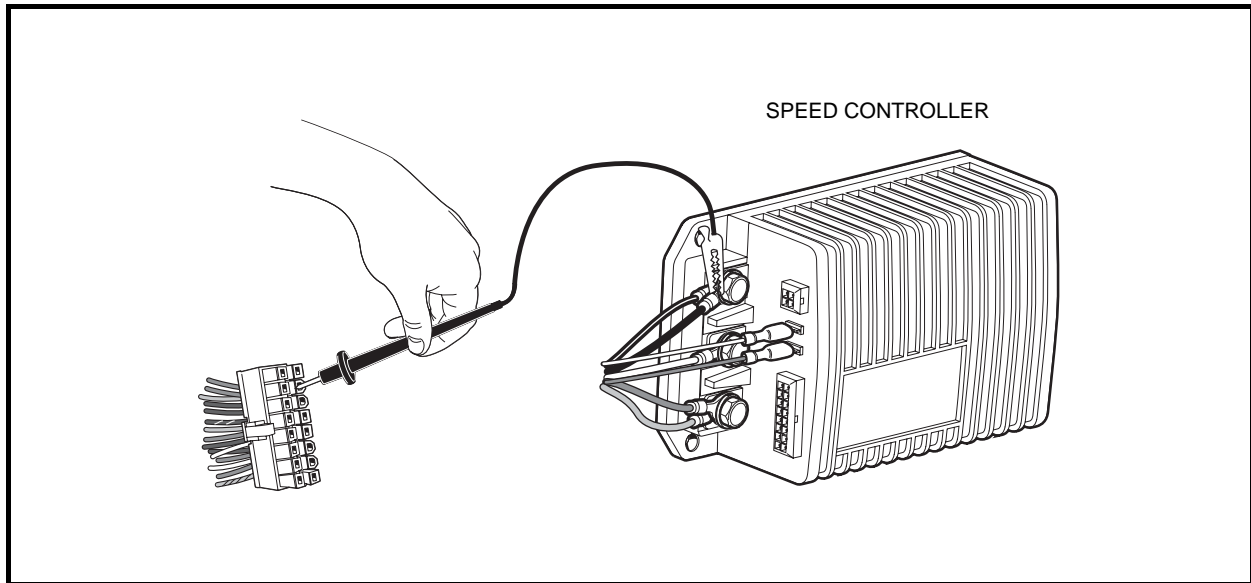


Figure 11-16 Pin 7 Test

**Test Procedure 9E – Pins 8 and 16****See General Warning, Section 10, Page 10-1.**

Pins 8 and 16 in the 16-pin connector provide a connection point for the Forward/Reverse rocker switch to the speed controller. The switch provides a +48 volt signal to the speed controller through pin 8 when the Forward/Reverse switch is in the FORWARD position and provides a +48 volt signal on pin 16 when the Forward/Reverse switch is in the REVERSE position.

1. Disconnect the battery cables as instructed. **See WARNING "To avoid unintentionally starting..." in General Warning, Section 10, Page 10-1.**
2. Place chocks at the front wheels and lift the rear of the vehicle with a chain hoist or floor jack. Position jack stands under the frame crossmember between the spring mount and side stringer, just forward of each rear wheel.
3. Disconnect the 16-pin connector at the speed controller.
4. Using a multimeter set for 200 volts DC, insert the red (+) probe of the multimeter into pin 8 (brown wire) of the 16-pin connector. **See following CAUTION.** Using an alligator clip, connect the black (–) probe to the B– terminal of the speed controller (**Figure 11-17, Page 11-31**).

** CAUTION**

- **Do not fully insert probes into the 16-pin plug. Doing so can result in a poor connection.**

5. Place the Tow/Run switch in the TOW position and connect the battery cables, positive (+) cable first. Tighten battery terminals to 110 in-lb (12.4 N·m).
6. Place the Tow/Run switch in the RUN position and the Forward/Reverse switch in the NEUTRAL position. The multimeter should indicate zero volts DC at this time.
7. While monitoring the multimeter, place the Forward/Reverse switch in the REVERSE position. The multimeter should still indicate zero volts.
8. Place the Forward/Reverse switch in the FORWARD position. The multimeter should indicate full battery voltage (approximately 48 volts).
9. Insert the red (+) probe of the multimeter into pin 16 (blue wire) of the 16-pin connector. Leave the black (-) probe (alligator clip) connected to the B- terminal of the speed controller. **See previous CAUTION.**
10. Place the Forward/Reverse switch in the NEUTRAL position. The multimeter should indicate zero volts DC at this time.
11. While monitoring the multimeter, place the Forward/Reverse switch in the FORWARD position. The multimeter should still indicate zero volts.
12. Place the Forward/Reverse switch in the REVERSE position. The multimeter should indicate full battery voltage (approximately 48 volts).
13. If any other reading is obtained, check the following items:
  - Continuity of the wires in the wire harness
  - Forward/Reverse switch for proper operation. **See Test Procedure 15 – Forward/Reverse Rocker Switch on page 11-38.**
  - Tow/Run switch for proper operation. **See Test Procedure 6 – Tow/Run Switch on page 11-22.**

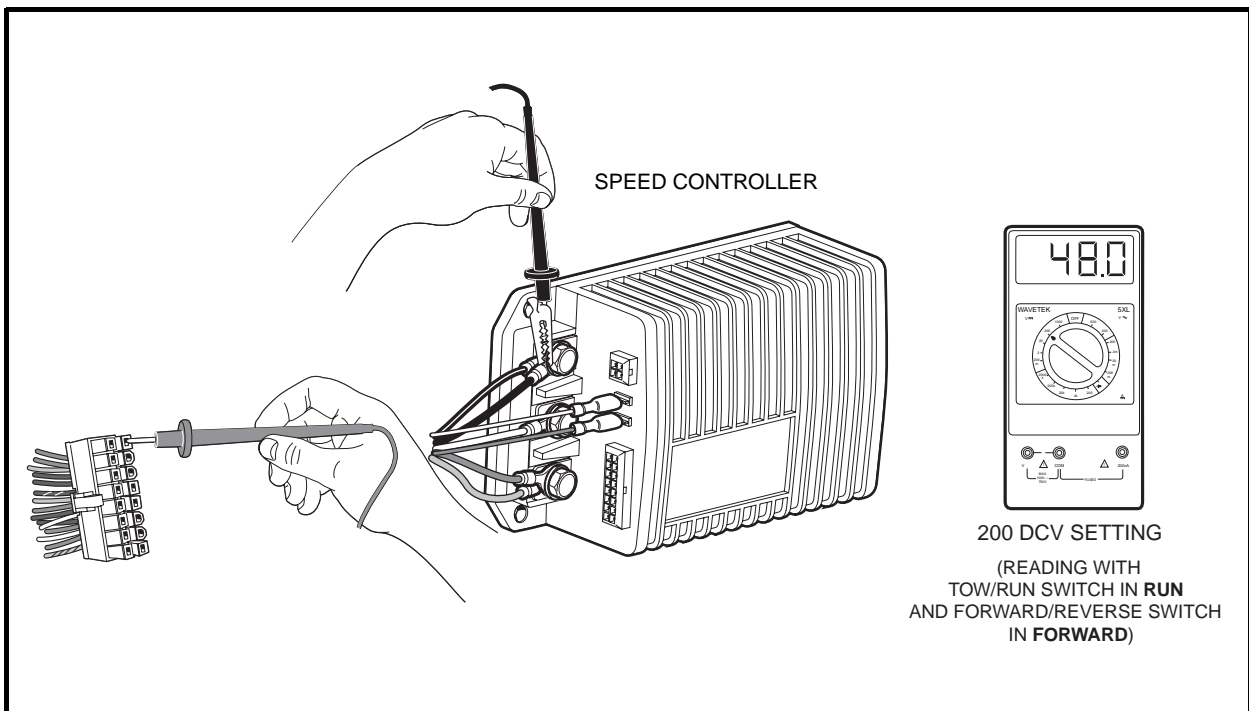


Figure 11-17 Pins 8 and 16 Test

## Test Procedure 9F – Pin 9

### See General Warning, Section 10, Page 10-1.

Pin 9 in the 16-pin connector provides a connection point for the Tow/Run switch to the speed controller. The switch provides a +48 volt signal to the speed controller through pin 9 when the Tow/Run switch is in the RUN position.

1. Disconnect the battery cables as instructed. **See WARNING "To avoid unintentionally starting..." in General Warning, Section 10, Page 10-1..**
2. Place chocks at the front wheels and lift the rear of the vehicle with a chain hoist or floor jack. Position jack stands under the frame crossmember between the spring mount and side stringer, just forward of each rear wheel.
3. Disconnect the 16-pin connector at the speed controller.
4. Using a multimeter set for 200 volts DC, insert the red (+) probe of the multimeter into pin 9 (gray wire) of the 16-pin connector. **See following CAUTION.** Using an alligator clip, connect the black (-) probe to the B- terminal of the speed controller (**Figure 11-18, Page 11-32**).

### **⚠ CAUTION**

- **Do not fully insert probes into the 16-pin plug. Doing so can result in a poor connection.**
5. Place the Tow/Run switch in the TOW position and connect the battery cables, positive (+) cable first. Tighten battery terminals to 110 in-lb (12.4 N·m).
  6. With the Tow/Run switch in the TOW position, the multimeter should indicate zero volts.
  7. Place the Tow/Run switch in the RUN position.
  8. With the Tow/Run switch in the RUN position, the multimeter should indicate full battery voltage (approximately 48 volts).
  9. If any other reading is obtained, check the following items:
    - Continuity of the wires in the wire harness
    - Tow/Run switch for proper operation. **See Test Procedure 6 – Tow/Run Switch on page 11-22.**

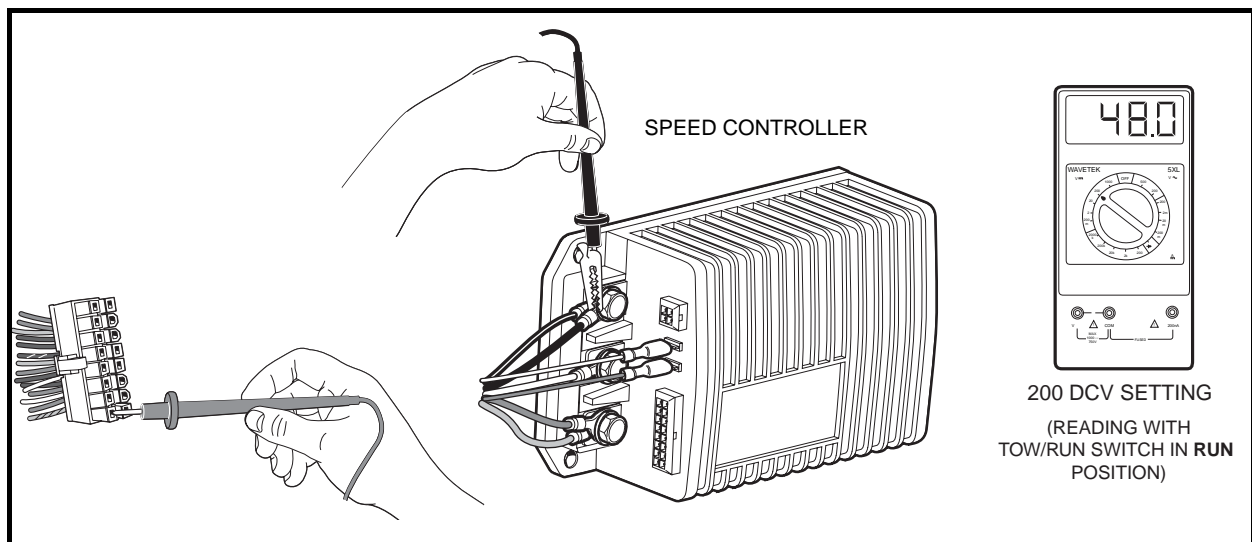


Figure 11-18 Pin 9 Test

## Test Procedure 9G – Pin 10

### See General Warning, Section 10, Page 10-1.

Pin 10 in the 16-pin connector provides a connection point for the key switch to the speed controller. The key switch provides a +48 volt signal to the speed controller through pin 10 when the key switch is in the ON position.

1. Disconnect the battery cables as instructed. **See WARNING "To avoid unintentionally starting..." in General Warning, Section 10, Page 10-1.**
2. Place chocks at the front wheels and lift the rear of the vehicle with a chain hoist or floor jack. Position jack stands under the frame crossmember between the spring mount and side stringer, just forward of each rear wheel.
3. Disconnect the 16-pin connector at the speed controller.
4. Using a multimeter set for 200 volts DC, insert the red (+) probe of the multimeter into pin 10 (tan wire) of the 16-pin connector. **See following CAUTION.** Using an alligator clip, connect the black (–) probe to the B– terminal of the speed controller (**Figure 11-19, Page 11-33**).

### **⚠ CAUTION**

- Do not fully insert probes into the 16-pin plug. Doing so can result in a poor connection.

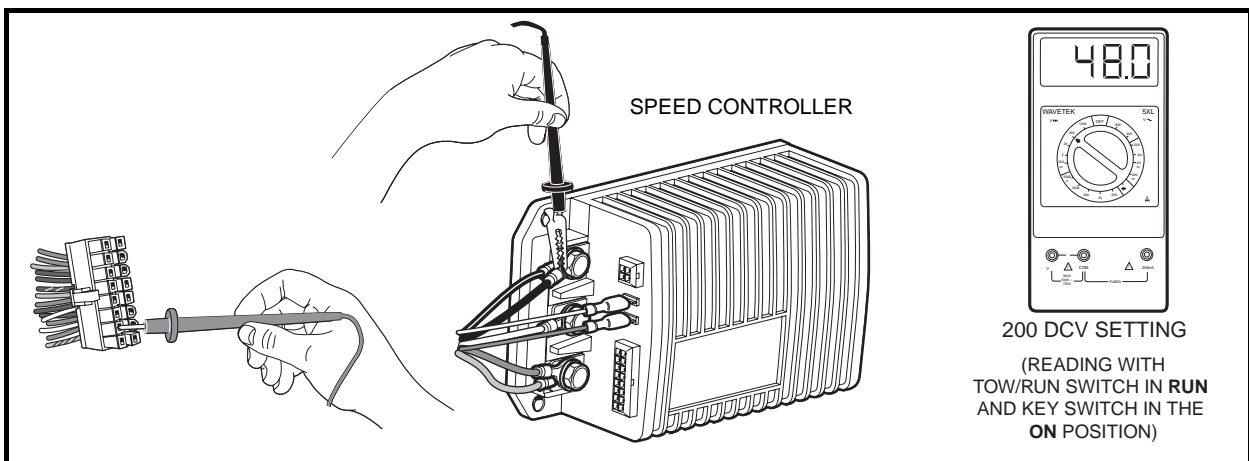


Figure 11-19 Pin 10 Test

5. Place the Tow/Run switch in the TOW position and connect the battery cables, positive (+) cable first. Tighten battery terminals to 110 in-lb (12.4 N-m).
6. With the Tow/Run switch in the TOW position, the multimeter should indicate zero volts.
7. Place the Tow/Run switch in the RUN position and the key switch in the ON position.
8. With the key switch in the ON position, the multimeter should indicate full battery voltage (approximately 48 volts). With the key switch in the OFF position, the reading should be zero volts.
9. If any other reading is obtained, check the following items:
  - Continuity of the wires in the wire harness
  - Tow/Run switch for proper operation. **See Test Procedure 6 – Tow/Run Switch on page 11-22.**
  - Key switch for proper operation. **See Test Procedure 8 – Key Switch and MCOR Limit Switch Circuit on page 11-23.**



## Test Procedure 9H – Pin 12

### See General Warning, Section 10, Page 10-1.

Pin 12 in the 16-pin connector provides a connection point for the solenoid coil to the speed controller. The speed controller activates the solenoid coil by providing a ground to the solenoid coil at the appropriate time.

1. Disconnect the battery cables as instructed. **See WARNING "To avoid unintentionally starting..." in General Warning, Section 10, Page 10-1.**
2. Place chocks at the front wheels and lift the rear of the vehicle with a chain hoist or floor jack. Position jack stands under the frame crossmember between the spring mount and side stringer, just forward of each rear wheel.
3. Disconnect the 16-pin connector at the speed controller.
4. Place a jumper wire with an alligator clip between the B– terminal of the speed controller (use alligator clip for this connection) and pin 12 (blue/white wire) of the 16-pin connector (**Figure 11-20, Page 11-34**). **See following CAUTION.**

### **⚠ CAUTION**

- **Do not fully insert probes into the 16-pin plug. Doing so can result in a poor connection.**
5. Place the Tow/Run switch in the TOW position and connect the battery cables, positive (+) cable first. Tighten battery terminals to 110 in-lb (12.4 N·m).
  6. Place the Tow/Run switch in the RUN position and the key switch in the ON position.
  7. The solenoid should click when the key switch is placed in the ON position.
  8. If any other activity is observed, check the following items:
    - Continuity of the wires in the wire harness
    - Reverse buzzer for proper operation. **See Test Procedure 16 – Reverse Buzzer on page 11-39.**
    - Tow/Run switch for proper operation. **See Test Procedure 6 – Tow/Run Switch on page 11-22.**
    - Key switch for proper operation. **See Test Procedure 8 – Key Switch and MCOR Limit Switch Circuit on page 11-23.**
    - Solenoid for proper operation. **See Test Procedure 14 – Solenoid Continuity on page 11-37.**

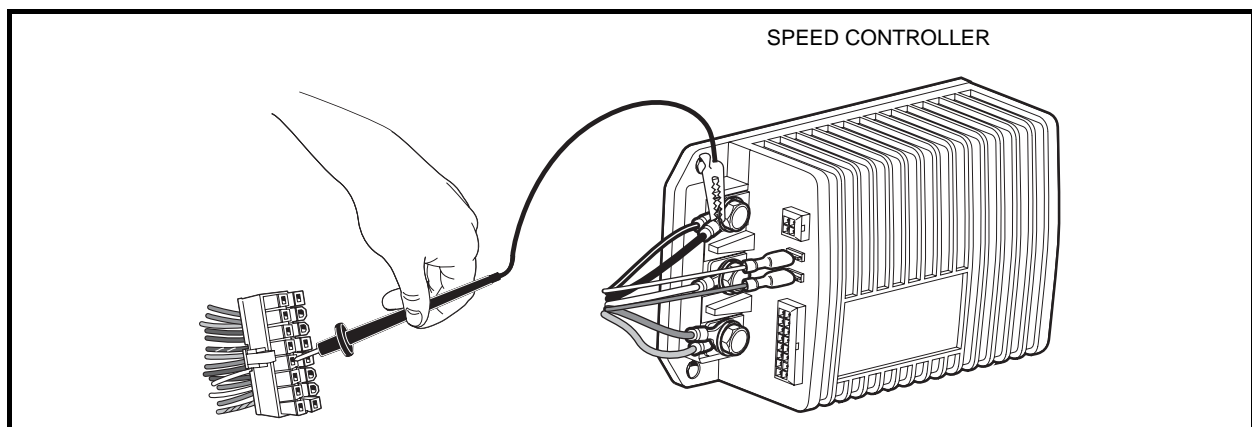


Figure 11-20 Pin 12 Test



## TEST PROCEDURE 10 – ONBOARD COMPUTER SILICON-CONTROLLED RECTIFIER (SCR) CIRCUIT

**See General Warning, Section 10, Page 10-1.**

The silicon controlled rectifier (SCR), located inside the onboard computer, acts as a switch on the negative side of the circuit.

This allows the onboard computer (OBC) to control the battery charging current.

Use the following procedure to test the SCR:

1. With batteries connected and using a multimeter set to 200 volts DC, place the red (+) probe on the positive post of battery no. 1 and place the black (–) probe on the charger receptacle fuse terminal that has the black 10-gauge OBC wire attached to it. The reading should be approximately 36-42 volts.
2. If the reading is zero volts, check the black 10-gauge wire connections at the controller and receptacle. Check the continuity of the black 10-gauge wires. If the wires and connections are okay, the SCR has failed. Replace the OBC. If the reading is correct, proceed to the following step.
3. Plug in AC and DC cords. When the battery charger relay clicks on, reading should be approximately 48 volts (full battery voltage). If the reading does not rise from approximately 40 volts to full battery voltage when the DC cord is plugged in and the relay clicks on, check the following items:
  - Charger receptacle fuse and black wire terminal socket in the charger receptacle.
  - Onboard computer gray wire and fuse. **See Test Procedure 11 – Onboard Computer Gray Wire and Fuse on page 11-35.**
  - Red wire at the charger receptacle. **See Test Procedure 12 – Voltage at Charger Receptacle Red Wire Socket on page 11-35.**

## TEST PROCEDURE 11 – ONBOARD COMPUTER GRAY WIRE AND FUSE

**See General Warning, Section 10, Page 10-1.**

1. With batteries connected and using a multimeter set to 200 volts DC, connect the red (+) probe to the positive post of battery no. 1 and black (–) probe (with insulation-piercing probe) to gray 16-gauge wire at a point between fuse and receptacle. Reading should be approximately 48 volts. If reading is zero volts, check gray wire fuse and fuse holder for continuity.
2. If the reading in step 1 is 48 volts, plug the DC cord into the vehicle's charger receptacle. The voltage reading should drop to approximately 4.0 volts before the charger relay clicks on.
3. When the charger relay is activated, the reading should rise to approximately 48 volts.
4. If voltage does not drop to approximately 4.0 volts when the DC cord is plugged in and then rise to approximately 48 volts when the charger relay clicks on, the gray wire circuit in the OBC has failed. Replace the OBC.

## TEST PROCEDURE 12 – VOLTAGE AT CHARGER RECEPTACLE RED WIRE SOCKET

**See General Warning, Section 10, Page 10-1.**

1. With batteries connected and using a multimeter set to 200 volts DC, place the black (–) probe on the negative post of battery no. 6 and place the red (+) probe on the charger receptacle socket connected to the red 10-gauge wire. The reading should be 48-50 volts (full battery voltage).
2. If the reading is zero volts, check the continuity of the 10-gauge red wire from the positive post of battery no. 1 to the receptacle socket.

## TEST PROCEDURE 13 – MOTOR SPEED SENSOR

See General Warning, Section 10, Page 10-1.

### Motor Speed Sensor Test with the IQDM Handset

#### **⚠ CAUTION**

- Perform the following procedure only on a level surface. To avoid injury or property damage, ensure that the path of the vehicle is clear before pushing vehicle.
1. Turn the key switch to the OFF position and place the Forward/Reverse switch in the NEUTRAL position.
  2. Connect the IQDM to the vehicle as described in the IQDM Owner's Manual.
  3. Access the Test menu and select SPEED PULSES by using the SCROLL DISPLAY buttons. The IQDM should indicate OFF when the vehicle is at rest.
  4. While monitoring the IQDM display screen, slowly push the vehicle a short distance (about 3 feet (1 meter)). The IQDM should indicate ON for speed sensor pulses while the wheels are in motion.
  5. If the IQDM does not indicate ON while the wheels are in motion, proceed to the following procedure, Motor Speed Sensor Test without the IQDM Handset.

### Motor Speed Sensor Test without the IQDM Handset

1. Turn the key switch to the OFF position and place the Forward/Reverse switch in the NEUTRAL position.
2. With batteries connected, disconnect the three-pin connector at the motor speed sensor.
3. Check voltage at black/white wire:
  - 3.1. Using a multimeter set to 200 volts DC, place the red (+) probe on the battery no. 1 positive post and place the black (–) probe on the black/white wire terminal socket in the three-pin connector. The voltage reading should be 48 to 50 volts (full battery voltage).
  - 3.2. If the reading is zero volts, check the continuity of the black/white wire from the 16-pin connector at the speed controller to the three-pin connector at the motor speed sensor. If the continuity is correct, replace the speed controller.
4. Check voltage at the red motor speed sensor wire:
  - 4.1. With Tow/Run switch in the RUN position and using a multimeter set to 20 volts DC, place the black (–) probe on the battery no. 6 negative post and place red (+) probe on red wire terminal socket in three-pin connector. The voltage reading should be approximately 15-16 volts.
  - 4.2. If the voltage reading is zero volts, check the continuity of the red wire from the 16-pin connector at the speed controller to the three-pin connector at the motor speed sensor. If the wire continuity is correct, replace the speed controller.
  - 4.3. If the reading is below 14 volts, replace the speed controller.
  - 4.4. If the voltage reading is correct, proceed to the following step.
5. Check voltage at the light green wire:
  - 5.1. Using a multimeter set to 20 volts DC, place the black (–) probe on the battery no. 6 negative post and place the red (+) probe on the light green wire female terminal in the three-pin connector at the motor speed sensor. The voltage reading should be from 4.60 to 4.90 volts.
  - 5.2. If the voltage is zero volts, check the continuity of the light green wire from the 16-pin connector at the speed controller to the three-pin connector at the motor speed sensor. If the continuity is correct, replace the speed controller.
  - 5.3. If reading is below 3.50 volts, check the continuity of the wires and plug and replace the speed controller if necessary.

**Motor Speed Sensor Test without the IQDM Handset, Continued:**

6. Reconnect the three-pin connector at the motor speed sensor. Using a multimeter set to 20 volts DC, place the black (–) probe on the battery no. 6 negative post and place the red (+) probe (with insulation-piercing probe) on the green wire between the three-pin connector and the motor speed sensor.
  - 6.1. Raise one rear wheel off ground. Slowly turn the rear wheel to rotate the motor armature. As the armature rotates, the voltage reading should alternate from zero to approximately 4.85 volts. The voltage reading will fluctuate from zero to 4.85 volts and back to zero four times for each revolution of the motor armature.

**NOTE:** The voltage reading of 4.85 is an approximate reading. The actual reading may vary from 4.50 to 5.00 volts.

- 6.2. Replace the speed sensor if:

- There is no voltage reading.
- The voltage reading is not above 3.50.
- The voltage reading does not fluctuate as the motor is turned.

**TEST PROCEDURE 14 – SOLENOID CONTINUITY****See General Warning, Section 10, Page 10-1.**

1. Place chocks at the front wheels and lift the rear of the vehicle with a chain hoist or floor jack. Position jack stands under the frame crossmember between the spring mount and side stringer, just forward of each rear wheel.
2. Disconnect the battery cables as instructed. **See WARNING "To avoid unintentionally starting..." in General Warning, Section 10, Page 10-1.**
3. Disconnect the yellow wire from the large post of the solenoid.
4. Disconnect the resistor terminal from the same large post as the removed wire.
5. Using a multimeter set to 200k ohms, place the black (–) probe on the solenoid large post with the 6-gauge yellow wire and place the red (+) probe on the large post with the 6-gauge red wire. The reading should be no continuity.
6. Connect the 6-gauge yellow wire and resistor to the large solenoid post. Install washer and nut on large solenoid post and tighten to 77 in-lb (8.7 N·m).
7. Place the Tow/Run switch in the TOW position and connect the battery cables, positive (+) cable first. Tighten battery terminals to 110 in-lb (12.4 N·m).
8. Place the Tow/Run switch in the RUN position, turn the key switch to the ON position, place the Forward/Reverse rocker switch in the FORWARD position, and press the accelerator pedal. The solenoid should click and the multimeter should indicate continuity. If the reading is no continuity, replace the solenoid.

## TEST PROCEDURE 15 – FORWARD/REVERSE ROCKER SWITCH

See General Warning, Section 10, Page 10-1.

### Forward/Reverse Rocker Switch Test with the IQDM Handset

1. Turn the key switch to the OFF position and place the Forward/Reverse switch in the NEUTRAL position.
2. Connect the IQDM to the vehicle as described in the IQDM Owner's Manual.
3. Test FORWARD INPUT.
  - 3.1. Access the Test menu and select FORWARD INPUT by using the SCROLL DISPLAY buttons. The IQDM should indicate OFF when the Forward/Reverse switch is in the NEUTRAL or REVERSE position.
  - 3.2. Place the Forward/Reverse switch in the FORWARD position. The IQDM should indicate that FORWARD INPUT is ON. If the IQDM indicates any other reading, check vehicle wiring. **See Wiring Diagram on page 11-10.** Also check the 16-pin connector at the speed controller. **See Test Procedure 9 – 16-Pin Connector on page 11-25.**
4. Test REVERSE INPUT.
  - 4.1. Access the Test menu and select REVERSE INPUT by using the SCROLL DISPLAY buttons. The IQDM should indicate OFF when the Forward/Reverse switch is in the NEUTRAL or FORWARD position.
  - 4.2. Place the Forward/Reverse switch in the REVERSE position. The IQDM should indicate that REVERSE INPUT is ON. If the IQDM indicates any other reading, check vehicle wiring. **See Wiring Diagram on page 11-10.** Also check the 16-pin connector at the speed controller. **See Test Procedure 9 – 16-Pin Connector on page 11-25.**
5. If the IQDM displays readings other than those described above and the wiring is found to be correct, proceed to the following procedure, Forward/Reverse Rocker Switch Test without the IQDM Handset.

### Forward/Reverse Rocker Switch Test without the IQDM Handset

1. Disconnect the battery cables as instructed. **See WARNING "To avoid unintentionally starting..." in General Warning, Section 10, Page 10-1.**
2. Remove the three screws securing the rocker switch case to the vehicle body.
3. Disconnect the three wires from the rocker switch. Using a multimeter set to 200 ohms, place the black (–) probe on the blue wire terminal 3 position on the rocker switch, and place the red (+) probe on the orange wire terminal 2 position. With the switch in NEUTRAL or REVERSE, there should be no continuity. With the switch in FORWARD, there should be continuity. If the readings are incorrect, replace the switch.
4. Place the black (–) probe on the brown wire terminal 1 position on the rocker switch and place the red (+) probe on the orange wire terminal. With the switch in REVERSE, there should be continuity. If the readings are incorrect, replace the switch.

## TEST PROCEDURE 16 – REVERSE BUZZER

See General Warning, Section 10, Page 10-1.

1. Disconnect the battery cables as instructed. **See WARNING "To avoid unintentionally starting..." in General Warning, Section 10, Page 10-1.**
2. Remove the center dash:
  - 2.1. Remove the plastic cap covering the screw on each side of the center dash panel. Loosen (but do not remove) these screws.
  - 2.2. Insert screwdriver at the top center of the dash between dash and cowl brace. Gently pry center dash out from under edge of cowl brace.
  - 2.3. Pull dash out approximately one inch (2.5 cm) from the frame and then bend the top right corner of the dash inward while pulling the top of the panel out and down. **See following NOTE.**

**NOTE:** *Bending the top right corner of the center dash inward during removal will prevent the contacts on the back of the key switch from touching the metal frame around the dash.*

- 2.4. Slide the dash panel up the steering column by snapping the top out and then rotating the panel out and up.
- 2.5. Disconnect the orange/white and red wires from the reverse buzzer. Make sure the wire terminals on the key switch do not touch vehicle frame.
3. Place the Tow/Run switch in the TOW position and connect the battery cables, positive (+) cable first. Tighten battery terminals to 110 in-lb (12.4 N·m).
4. Place the Tow/Run switch in the RUN position.
5. Using a multimeter set to 200 volts DC, place the black (–) probe on battery no. 6 negative post and place the red (+) probe on the red wire terminal end that was disconnected from the reverse buzzer. The reading should be approximately 48 volts (full battery voltage).
  - 5.1. If the voltage reading is correct, proceed to step 6.
  - 5.2. If reading is zero volts, check red wire continuity and Tow/Run switch. **See Test Procedure 2 – Onboard Computer Solenoid Lockout Circuit on page 11-17. See also Test Procedure 6 – Tow/Run Switch on page 11-22.**
  - 5.3. If the continuity readings are not correct, repair or replace the red wire.
  - 5.4. If the continuity readings are correct, proceed to step 6.
6. Place the Forward/Reverse switch in REVERSE. Using a multimeter set to 200 volts DC, place the black (–) probe on the orange/white wire terminal end (that was disconnected from the reverse buzzer) and place the red (+) probe on battery no. 1 positive post. The reading should be approximately 48 volts (full battery voltage).
  - 6.1. If the voltage reading is correct, replace the reverse buzzer.
  - 6.2. If reading is zero volts, check orange/white wire continuity and connection at Pin 10 in 23-Pin connector.
  - 6.3. If there is no continuity in the orange/white wire, or the Pin 10 terminal in the 23-Pin connector is not properly seated, repair or replace as required.
  - 6.4. If the orange/white wire continuity and 23-Pin connector are correct and there is no voltage at the orange wire, replace the controller.

## TEST PROCEDURE 17 – REBOOTING THE ONBOARD COMPUTER

### See General Warning, Section 10, Page 10-1.

It is possible the Onboard Computer (OBC) can become “locked up”, causing the OBC solenoid lockout circuit to malfunction. If this condition is suspected, restart the computer as follows:

1. Disconnect the battery cables as instructed. **See WARNING "To avoid unintentionally starting..." in General Warning, Section 10, Page 10-1. See following NOTE.**

**NOTE:** Wait at least 90 seconds for the capacitors in the speed controller to discharge. The capacitors in the speed controller must be fully discharged in order to reboot the OBC.

2. Place the Tow/Run switch in the TOW position and connect the battery cables, positive (+) cable first. Tighten battery terminals to 110 in-lb (12.4 N·m) and coat terminals with Battery Terminal Protector Spray (CCI P/N 1014305) to minimize corrosion.
3. Place Tow/Run switch in the RUN position.
4. Test drive the vehicle. If the problem has been fixed, the vehicle will function normally. If the problem still exists, refer to Wiring Diagram on page 11-10.

## TEST PROCEDURE 18 – BATTERY WARNING LIGHT

### See General Warning, Section 10, Page 10-1.

1. Reboot the OBC and drive the vehicle a short distance. When vehicle is first driven, the battery warning light should illuminate for 10 seconds. **See Test Procedure 17 – Rebooting the Onboard Computer on page 11-40.** If the battery warning light does not illuminate when rebooting the OBC, proceed to step 2.
2. Turn key switch OFF, place Tow/Run switch in TOW and place Forward/Reverse rocker switch in NEUTRAL.
3. Disconnect the six-pin connector at the OBC.
4. Remove the wedge lock from the six-pin connector housing that is connected to the vehicle wire harness. Remove the brown/white wire from the connector plug.
5. Using a jumper wire with an alligator clip at each end, connect one alligator clip to the negative post of battery no. 1 and the other alligator clip to the brown/white wire terminal socket that was removed from the six-pin connector plug.
6. Install the wedgelock in the six-pin connector housing and reconnect the six-pin connector plug. Place the Tow/Run switch in the RUN position and the battery light should illuminate. If the light does not illuminate, replace the battery warning light assembly.

## COMMUNICATION DISPLAY MODULE (CDM)

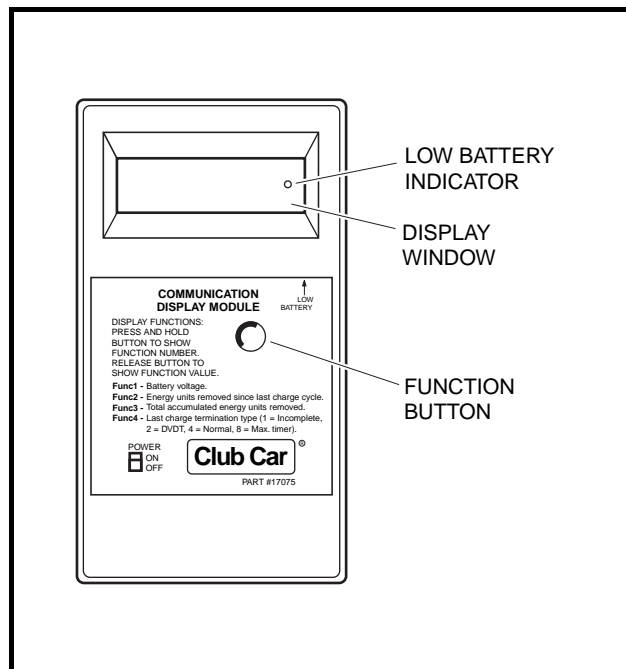


Figure 11-21 CDM

The CDM can be used to retrieve from the onboard computer four important items of information that can be useful in troubleshooting the IQ System vehicle. To access one of these items, the item's corresponding Function Code must be selected on the CDM. This is done by pressing the Function Button until the desired function code is displayed in the window. **See Figure 11-21, Page 11-41 for CDM features.** Releasing the button when the desired code is displayed will display the data. Function codes and corresponding data are as follows:

- **F1 – Battery voltage:**

This displays the battery pack's current state of charge. A reading of less than 48 volts indicates that the batteries need to be charged. If a reading of less than 48 volts is obtained immediately after a charge cycle, there may be a problem in the charge circuit.

- **F2 – Energy units removed since last charge cycle:**

If the display reads over 75 (the vehicle battery warning light should be illuminated), the vehicle batteries need to be recharged before being used again. This data can be used to make sure all vehicles in a fleet receive equal usage on a short-term basis.

- **F3 – Total accumulated energy units removed since initial vehicle start-up:**

This information is most useful in making sure that all vehicles in a fleet receive equal usage over long periods of time.

- **F4 – Last charge termination type (1 = incomplete, 2 = DVDT, 4 = normal, 8 = max. timer):**

A **1, 2, 4, or 8** will be displayed.

**1** – Indicates the last charge cycle was incomplete and the batteries were not fully charged. Batteries should be charged again at the earliest opportunity.

**2** – Indicates a back-up charge program was employed by the OBC to complete the charge cycle. A DVDT charge may be displayed the first few times a new set of batteries is charged, and the first time a set of batteries is charged after the batteries have been disconnected and reconnected. A problem may exist if persistent DVDT readings are obtained.

**4** – Indicates the last charge cycle was normal.

**8** – Indicates the charger ran for sixteen hours and shut itself off without completing the charge cycle. This means there may be a problem in the charge circuit.

The CDM also has a low battery indicator, which illuminates when CDM batteries are weak and need to be replaced. Weak batteries in the CDM may cause the CDM to register inaccurate information or no information.

## USING THE CDM TO RETRIEVE DATA FROM THE ONBOARD COMPUTER

1. Turn the CDM ON.
2. Position CDM on seat bottom so it is aligned directly with the battery warning light. Ensure CDM infrared LED receiver is pointed at battery warning light and there is a clear path between them. **See following NOTE.**

**NOTE:** *If, by positioning CDM on seat bottom, the CDM is unable to collect the data stream from the onboard computer, hold CDM approximately 6 inches (15.2 cm) from battery warning light.*

3. Wait approximately 30 seconds for a value to appear in the display window.
4. If a value does not appear in the display window after 30 seconds, try adjusting the aim of the CDM and repeating step 3 until a value appears. If there is still no reading, check for weak batteries in the CDM.
  - 4.1. Adjust aim of CDM.
  - 4.2. Drive vehicle a short distance to ensure OBC is not in powerdown mode.
  - 4.3. Check for weak batteries in CDM.
  - 4.4. If reading is still not obtained, go to the CDM Troubleshooting Guide on page 11-43.

Once a value has been obtained in the display window, the CDM may be removed from its receiving position and the data reviewed. The CDM will hold the values for F1, F2, F3, and F4 until the CDM is turned OFF or it receives another line of data from the same or another onboard computer. Use the following procedure to review the data stored in the CDM:

- The value currently displayed will be F1 (battery voltage).
- To view F2, press and hold the button on the CDM. When “Func 2” appears in the display window, release the button. The value for F2 will then be displayed.
- To view F3, press and hold the button on the CDM until “Func 3” appears in the display window. Release the button. The value for F3 will be displayed.
- To view F4, press and hold the button on the CDM until “Func 4” appears in the display window. Release the button. The value for F4 will be displayed.

**NOTE:** *The values of all four functions can be recalled by pressing and releasing the CDM button.*



## CDM TROUBLESHOOTING GUIDE

Use the following chart as a starting point for troubleshooting problems with communication between the CDM and onboard computer. Contact your Club Car representative for more comprehensive information.

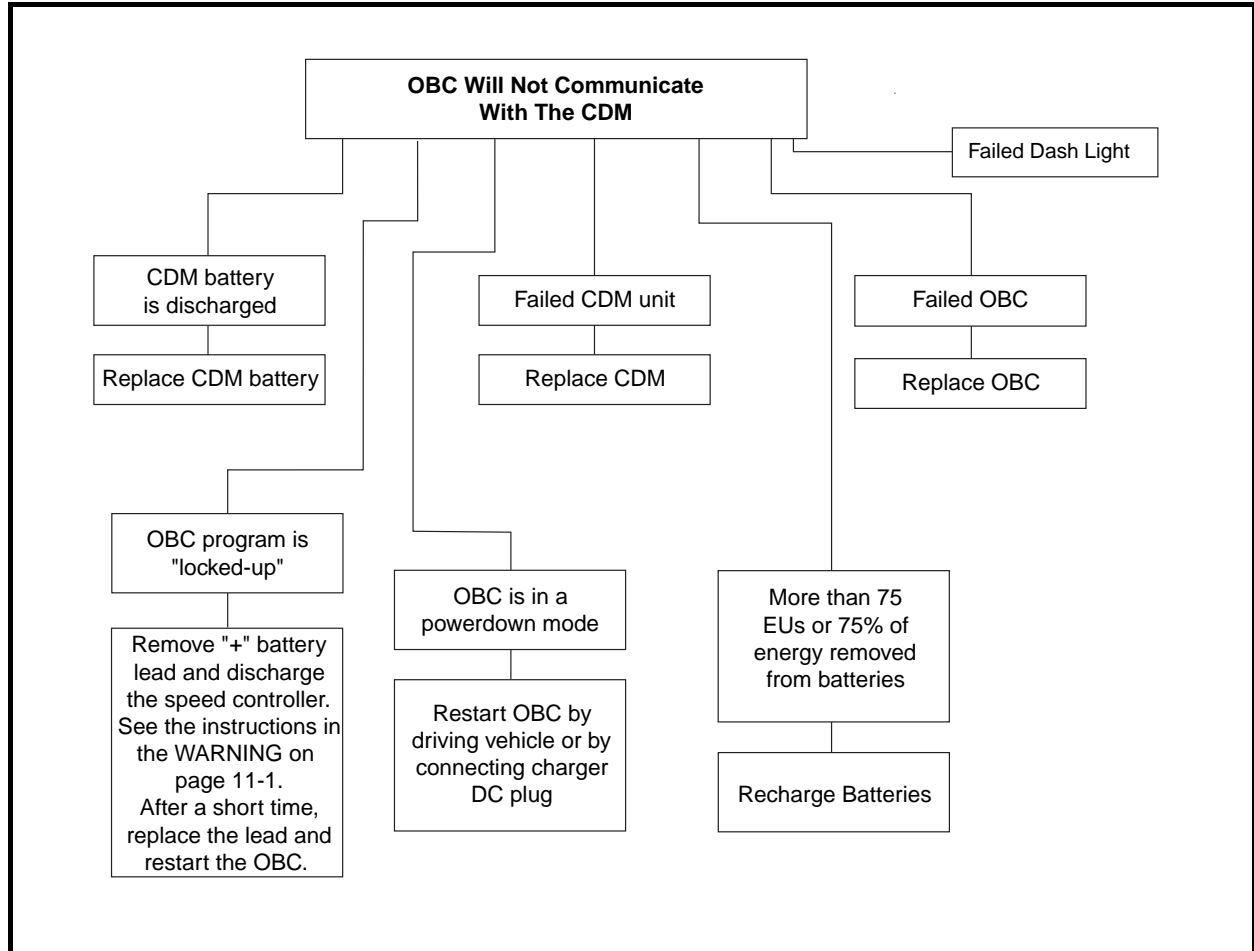


Figure 11-22 Flow Chart – CDM Troubleshooting Guide



## SECTION 12 – IQ DISPLAY MODULE (IQDM) AND IQDM-P DIAGNOSTICS

---

### **⚠ DANGER**

- See General Warning, Section 10, Page 10-1.

### **⚠ WARNING**

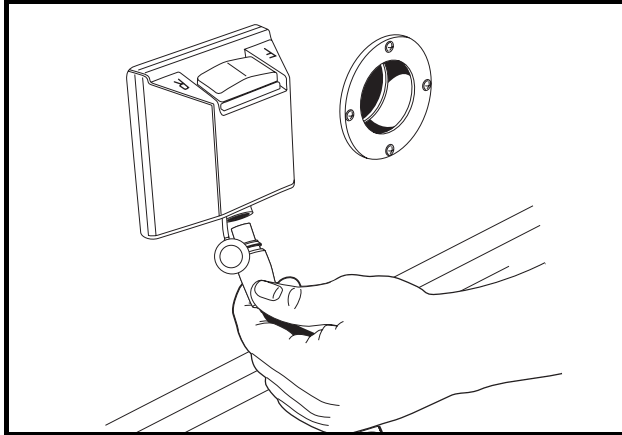
- See General Warning, Section 10, Page 10-1.

**NOTE:** For information specific to the IQDM-P programming features, See **Section 18 – IQ DISPLAY MODULE (IQDM-P) Programming.**

### PLUGGING THE HANDSET INTO THE VEHICLE

---

1. Connect one end of the cable to the jack located on the bottom of the handset.
2. Connect the cable adaptor to the IQDM cable.
3. Find the IQDM jack on the vehicle.
4. Remove the dust cap from the IQDM jack.
5. Align the keyed portion of the plug with the IQDM jack and connect the plug to the jack.



**Figure 12-1 Connector Under Forward/Reverse Switch**

## INTRODUCTORY DISPLAY

---

Immediately after the handset is connected to the vehicle, it begins loading the vehicle speed controller information. After a few seconds, the screen displays the following menu items:

- Program (IQDM-P)
- Monitor
- Faults
- Functions
- Information
- Programmer Setup

In the event that the handset does not display any information, or the screen is difficult to read, refer to the IQDM troubleshooting procedures. **See IQDM and IQDM-P Handset Troubleshooting on page 12-15.**

## MENU NAVIGATION

---

The NAVIGATION BUTTON is the four-arrow button located on the left side of the handset (**Figure 12-2, Page 12-3**). This button is used to navigate through and select menus. Pressing the up or down arrows allows the user to scroll through the menu items. When the box beside the desired menu is blinking, pressing the right arrow selects that menu item. Pressing the left arrow allows the user to go back one screen.

The CHANGE VALUE BUTTON is the button located on the right side of the handset (**Figure 12-2, Page 12-3**). This button allows the user to change values by pressing + or –.

The three yellow buttons labeled 1, 2 and 3 are BOOKMARK BUTTONS (**Figure 12-2, Page 12-3**). These buttons allow the user to bookmark up to three specific screens for rapid return to those screens. To bookmark a specific display screen, have the desired screen displayed and simply press and hold a bookmark button until the statement “bookmark set” is displayed. When it is necessary to go back to the bookmarked screen, rapidly press and release the appropriate bookmark button. **See following NOTE.**

**NOTE:** *When going to a bookmarked display screen, be sure to rapidly press and release the button. If the button is pressed and held for too long, the bookmark will be overridden with the current screen.*

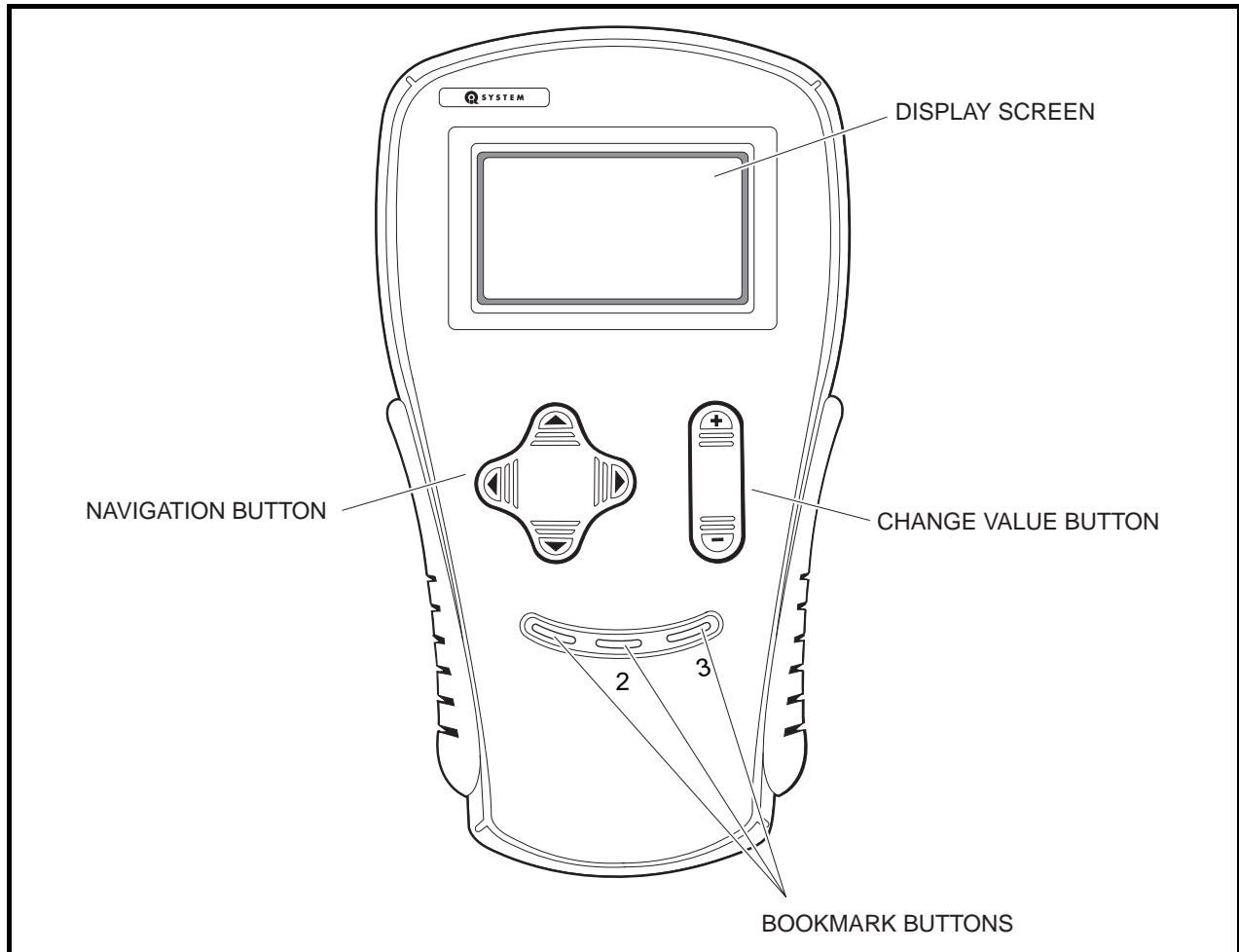


Figure 12-2 Handset Controls

The following menus are accessible on the IQDM handset:

### Program (IQDM-P only)

The *program* menu allows the user to view and change custom speed controller settings. **See Program Menu, Section 18, Page 18-2.**

### Monitor

The *monitor* menu displays values for certain parameters to facilitate speed controller troubleshooting. **See Monitor Menu on page 12-4.**

### Faults

The *faults* menu displays all faults recorded by the speed controller since the history was last cleared. Each fault is listed only once, even if the fault has occurred multiple times. **See Faults Menu on page 12-6.**

### Functions

The *functions* menu allows the user to transfer all current settings from the speed controller to the handset and from the handset to the speed controller. **See Functions Menu on page 12-10.**

## Information

The *information* menu displays the model number, serial number, manufacturer date and software version of the speed controller. **See Information, Section 12, Page 12-13.**

## Programmer Setup

The *programmer setup* menu allows the user to set the LCD contrast, display the fault history of the programmer as well as various other information pertaining to the handset such as model number, serial number, OEM information, etc. **See Programmer Setup, Section 12, Page 12-13.**

## MONITOR MENU

---

The *monitor* menu is accessed by using the up or down arrow to scroll to *monitor* and pressing the right arrow key to activate the menu. All information in the *monitor* menu is updated in real time, allowing the trained technician to troubleshoot the vehicle by monitoring the handset as the key switch is cycled, Forward/Reverse switch is activated, etc.

Since the *monitor* menu is updated while the vehicle is in operation, the trained technician has the ability to monitor the status of several components in conditions or locations where a problem with vehicle performance has been reported. **See following WARNING.**

### **WARNING**

---

- **The vehicle operator should not monitor the handset while the vehicle is in motion. A technician can monitor the handset while traveling as a passenger in the vehicle. Failure to heed this warning could result in severe personal injury or death.**

The following parameters can be monitored in real time with the handset from the *monitor* menu:

### **Throttle**

Indicates the position of the accelerator pedal from 0% (pedal not pressed) to 95 - 100% (pedal fully pressed). This item can be monitored when the key switch is in the ON or OFF position.

### **Batt Voltage**

Displays the current battery voltage at the speed controller.

### **Heatsink**

Displays the temperature (in degrees Celsius) of the speed controller heatsink. During normal operating conditions, the heatsink temperature should be below 85 °C ±5 °C (185 °F ±9 °F). **See following NOTE.**

**NOTE:** *Improper brake adjustment can sometimes cause the operating current to be higher than normal. This higher current increases the temperature of the speed controller heatsink.*

### **Arm Current**

Displays the motor armature current (in amperes).

### **Field Current**

Displays the motor field current (in amperes).

## Arm PWM

Displays motor armature PWM (pulse width modulation). The range of pulse width modulation is 0% to 100%. When the vehicle is operating at full speed, the pulse width modulation should be at 100%.

## Field PWM

Displays motor field PWM (pulse width modulation). The range of pulse width modulation is 0% to 100%. When the vehicle is in operation, the pulse width modulation will fluctuate in response to the terrain and throttle input.

## Speed Pulses

The *speed pulses* menu item displays the activity of the motor speed sensor. With the key switch in the OFF position, the Forward/Reverse switch in the NEUTRAL position, and the vehicle at rest, the handset should indicate that speed pulses are off. When the vehicle is gently pushed a short distance, the handset should indicate that speed pulses are on.

## Foot Input

Indicates the status of the MCO (motor controller output regulator) internal limit switch: on or off. When the accelerator pedal is unpressed, the handset should indicate that the limit switch is off. When the accelerator pedal is pressed and the key switch is in the ON position, the display should indicate that the limit switch is on.

## Forward Input

With the Forward/Reverse switch in the NEUTRAL or REVERSE position, the handset should indicate that the forward input is off. When the Forward/Reverse switch is placed in the FORWARD position, the handset should indicate that the forward input is on.

## Reverse Input

With the Forward/Reverse switch in the NEUTRAL or FORWARD position, the handset should indicate that the reverse input is off. When the Forward/Reverse switch is placed in the REVERSE position, the handset should indicate that the reverse input is on.

## Main Cont

Displays the current solenoid (main contactor) state. When the contactor is activated, the handset indicates that the solenoid is on. When the contactor is not activated, the handset indicates that the solenoid is off.

## Key Input

Displays the position of the key switch: OFF or ON.

## Password Tries (IQDM-P only)

A password is required to place the vehicle in "private speed mode" (speed setting 4). The speed controller will log unsuccessful and unauthorized attempts to place the speed controller in "private speed mode". If repeated attempts are unsuccessful, the speed controller will permanently lock out access to "private speed mode". In the event that "private speed mode" is locked out, the controller must be removed and shipped to Club Car before it can ever be placed in "private speed mode". **See Code A, Code B, and Code C, Section 18, Page 18-3.**

## 10.3 Transaxle

This menu is reserved for possible future use and has no application at this time.

## 20+ Speed

This menu is reserved for possible future use and has no application at this time.

## FAULTS MENU

---

The *faults* menu is accessed by using the up or down arrow to scroll to *faults* and pressing the right arrow key to activate the menu.

Faults displayed in the *faults* menu will aid the trained technician in troubleshooting the vehicle. Faults displayed often indicate which components in the electrical system need to be tested.

Since the *faults* menu is updated while the vehicle is in operation, the trained technician has the ability to monitor the occurrence of faults in conditions or locations where a problem with vehicle performance has been reported. **See following Warning.**

### **WARNING**

- **The vehicle operator should not monitor the handset while the vehicle is in motion. A technician can monitor the handset while traveling as a passenger in the vehicle. Failure to heed this warning could result in severe personal injury or death.**

## SYSTEM FAULTS

The *system faults* menu displays all of the faults detected by the speed controller since the last time the fault history has been cleared. The faults displayed in this menu may or may not be currently active. Once a fault has been detected, it is stored in the memory of the speed controller for display on the *fault history* menu. Each detected fault is listed only once, even if the fault has occurred multiple times.

## Causes of Faults

Some common causes of faults are:

- Loose, broken, or disconnected wires or connectors
- Failed components
- Improper adjustment or installation of electrical or mechanical components (examples: brake adjustment, improper MCOR installation)
- Improper wiring of electrical components

As shown above, there are many possible causes for faults to occur, and the speed controller has a programmed reaction to each fault that is based on the fault currently detected. The technician should be familiar with the detected faults and the controller's reactions to faults to ensure a proper diagnosis.

An example of a possible mis-diagnosis of a vehicle due to a fault: If the three-pin speed sensor wire has been disconnected, the speed controller will detect a *speed sensor* fault. When a *speed sensor* fault is detected, the controller responds to the fault by limiting the vehicle speed to 1/2 of its normal top speed. If the technician reaches the conclusion that the vehicle is running slowly because batteries are heavily discharged, he has made an improper diagnosis of the problem.

The vehicle speed controller should be checked for fault codes before any service is performed.

The speed controller, after detecting a fault, will respond in one or more of the following ways:

- A. Reduce vehicle speed to zero by reducing armature current
- B. Reduce vehicle speed to zero by reducing field current to zero
- C. Turn off the solenoid
- D. Cause the vehicle to run at half speed
- E. Gradually reduce the armature current limit
- F. Quickly reduce the armature current until speed sensor pulses occur



- G. Reduce field current and beep reverse buzzer at a fast rate

CONTROLLER FAULT	CONTROLLER RESPONSE
HW FAILSAFE	A, B, C
THROTTLE FAULT 1	A
SPEED SENSOR	D
MAIN WELDED	D
MAIN DRIVER ON	D
MAIN DRIVER OFF	A, C
MAIN CONT DNC	B
MAIN COIL FAULT	A
FIELD MISSING	A, B, C
HPD	A
PROC/WIRING	A
OVERVOLTAGE	A, B, G
LOW BATTERY	E
THERMAL CUTBACK	E
MOTOR STALL	F
MAIN DROPOUT	A, C
OPEN ARMATURE	A
MAX PASSWORD TRIES	(no action taken)
INCORRECT PASSWORD	(no action taken)

## Fault Recovery

When a fault is detected by the speed controller, the speed controller will attempt to recover from the fault and resume normal operation. In the case of an intermittent problem such as a loose wiring connection, the controller **may** be able to recover and operate normally for a while, but the problem should be repaired before placing the vehicle in service.

Depending on the type of fault, the controller will attempt to recover immediately after the condition clears or after the accelerator pedal has been cycled (released and pressed again).

CONTROLLER FAULT	CONTROLLER ATTEMPTS TO RECOVER
HW FAILSAFE	When key switch is cycled
THROTTLE FAULT 1	When condition clears
SPEED SENSOR	When condition clears
MAIN WELDED	When condition clears
MAIN DRIVER ON	When condition clears
MAIN DRIVER OFF	When accel. pedal is cycled

CONTROLLER FAULT	CONTROLLER ATTEMPTS TO RECOVER
MAIN CONT DNC	When accel. pedal is cycled
MAIN COIL FAULT	When accel. pedal is cycled
FIELD MISSING	When accel. pedal is cycled
HPD	When accel. pedal is cycled
PROC/WIRING	When condition clears
OVERVOLTAGE	When condition clears
LOW BATTERY VOLTAGE	When condition clears
THERMAL CUTBACK	When condition clears
MOTOR STALL	When condition clears
MAIN DROPOUT	When accel. pedal is cycled
OPEN ARMATURE	When condition clears and accel. pedal is cycled
MAX PASSWORD TRIES	When Tow/Run switch is cycled
INCORRECT PASSWORD	When Tow/Run switch is cycled

The following faults can be detected by the IQ System controller:

### HW Failsafe

The armature drive FET's (field effect transistors) regulate the armature current. If the speed controller detects a failure of the armature drive FET's or circuitry, a *hardware failsafe* fault is detected.

### Throttle Fault 1

If the MCOR (Motor Controller Output Regulator) voltage is less than 0.20 volts or greater than 4.80 volts, the controller detects a *throttle fault*.

### Speed sensor

If the speed controller does not detect pulses from the speed sensor while the controller outputs power (greater than 75% armature PWM) to the motor, a *speed sensor* fault is detected.

### Main Welded

If the speed controller detects that the solenoid contacts are welded closed, a *main welded* fault is detected.

### Main Driver On

If the FET that controls the closing of the solenoid contacts is found to be energized when it should not be, a *main driver on* fault is detected by the speed controller.

### Main Driver Off

If the FET that controls the closing of the solenoid is **not** energized when it should be, a *main driver off* fault is detected by the speed controller.

### Main Cont DNC

The *main cont dnc* (main contactor (solenoid) did not close) fault is detected when the speed controller has sent voltage to the solenoid activating coil but the solenoid contacts are not closed.

## Main Coil FAULT

If the speed controller determines that the solenoid is not closing as a result of a solenoid coil failure, a *main coil fault* is detected.

## Field Missing

If the speed controller is operating at a duty cycle of greater than 90% (almost full speed) and the field current is less than 3 amps, a *field missing* fault is detected by the speed controller.

## HPD

The *HPD* (High Pedal Detect) fault is detected if the accelerator pedal is already depressed when the key switch is turned to the ON position. This fault is also detected if the accelerator pedal is pressed when the selected direction is changed by pressing the Forward/Reverse switch. This fault, when not caused by the operator, can indicate that the pedal limit switch has failed closed.

## Proc/Wiring

This fault is detected if the Forward/Reverse switch is giving a signal to place the controller in forward and reverse at the same time. This rare fault can be caused by a failed Forward/Reverse switch or improper vehicle wiring.

## Overvoltage

If the speed controller detects that the battery voltage is too high (68.4 to 75.6 volts DC), the *overvoltage* fault is detected.

## Low Battery Voltage

If the battery voltage falls below 34 volts  $\pm 5\%$ , the *low battery voltage* fault is detected by the speed controller.

## Thermal Cutback

If the controller heatsink temperature is found to be in excess of  $85\text{ }^{\circ}\text{C} \pm 5\text{ }^{\circ}\text{C}$  ( $185\text{ }^{\circ}\text{F} \pm 9\text{ }^{\circ}\text{F}$ ) or below  $-25\text{ }^{\circ}\text{C} \pm 5\text{ }^{\circ}\text{C}$  ( $-13\text{ }^{\circ}\text{F} \pm 9\text{ }^{\circ}\text{F}$ ), the *thermal cutback* fault is detected.

## Motor Stall

If the motor current is high and there is no movement of the vehicle wheels for a short period of time, a *motor stall* is detected by the speed controller. This fault can be caused by an operator holding the vehicle on a hill by depressing the accelerator pedal instead of the brake pedal.

## Main Dropout

If the controller detects that the solenoid contacts have opened while the vehicle is in operation, a *main dropout* fault is detected.

## Open Armature

If the accelerator pedal is pressed 2/3 to the floor, the armature current is less than 20 amps, and there are no speed sensor pulses, an *open armature* fault is detected.

## Incorrect Password (IQDM-P only)

Each vehicle has a password in the form of a unique set of codes used to place the vehicle in "private speed mode". If a set of codes has been entered incorrectly, the *incorrect password* fault is declared. For additional information on codes, refer to Code A, Code B, and Code C. **See Code A, Code B, and Code C, Section 18, Page 18-3. See also Password Tries (IQDM-P only) on page 12-5.**

## Max Password Tries (IQDM-P only)

The *max password tries* fault is declared when the incorrect password fault has been declared several times. In the event that the *max password tries* fault is indicated, the speed controller must be removed and shipped

to Club Car before it can ever be placed in “private speed mode”. See **Code A, Code B, and Code C, Section 18, Page 18-3**. See also **Password Tries (IQDM-P only)** on page 12-5.

## Fault History

The *fault history* menu can be useful in determining the cause of a vehicle problem; however, the fault history alone should not be the factor that determines when a component is replaced. Some faults detected by the speed controller are not the result of a failed component, and are instead the result of vehicle operator error. If a fault appears in the *fault history* menu, the trained technician should attempt to determine when and where the fault has occurred. For example, if the *motor stall* fault is present in the fault history, the trained technician may be able to determine the location on the course where an operator has held the vehicle on a hill by using the accelerator pedal.

## Clearing Fault History

After a repair has been made, the fault history should be cleared. This will enable the trained technician to properly troubleshoot the vehicle in the future, in the event that another problem occurs. It is recommended that the fault history be cleared in order to avoid the replacement of a component that caused a fault in the past, but has been replaced and is now functioning correctly. For example, if the MCOR device was disconnected and the speed controller detected a fault code associated with the throttle, the fault history should be cleared so that any future problem is not diagnosed incorrectly as a throttle problem. See **Clear Fault History** on page 12-14.

## FUNCTIONS MENU

---

The *functions* menu is accessed by using the up or down arrow to scroll to *functions* and pressing the right arrow key to activate the menu.

## GET SETTINGS FROM CONTROLLER

This function transfers all of the speed controller settings (except for “private speed mode”) from the vehicle speed controller to the handset. This enables the trained technician to “clone” a speed controller. Once the speed controller settings have been transferred to the handset, the technician can then connect the handset to another vehicle and transfer the stored settings into the speed controller.

### Speed Controller Cloning – Transferring Settings from the Vehicle to the Handset

1. Locate a vehicle that has the desired speed controller settings.
2. Turn the key switch to the OFF position, place the Forward/Reverse handle in the NEUTRAL position, and lock the park brake.
3. Plug the handset into the vehicle.
  - 3.1. Connect one end of the cable to the jack located on the bottom of the handset.
  - 3.2. Connect the cable adaptor to the IQDM cable.
  - 3.3. Remove the dust cap from the IQDM jack.
  - 3.4. Align the keyed portion of the plug with the IQDM jack and connect the plug to the jack (**Figure 12-3** or **Figure 12-4**).
4. Scroll to the *functions* menu and select.
5. Select *settings*.
6. Select *get settings from controller*.
7. Press + on the change value button to confirm the operation.

8. The handset will display an “executing...” message for the next few seconds while the controller settings are being stored in the handset’s memory (**Figure 12-3**).
9. When the handset is finished recording the speed controller settings, a confirmation message is displayed (**Figure 12-4**).
10. With the controller settings stored in the memory of the handset, the handset can be used to transfer all of the desired speed controller settings to any IQ System vehicle or group of IQ System vehicles. **See Speed Controller Cloning – Transferring Settings from the Handset to the Vehicle on page 12-11.**

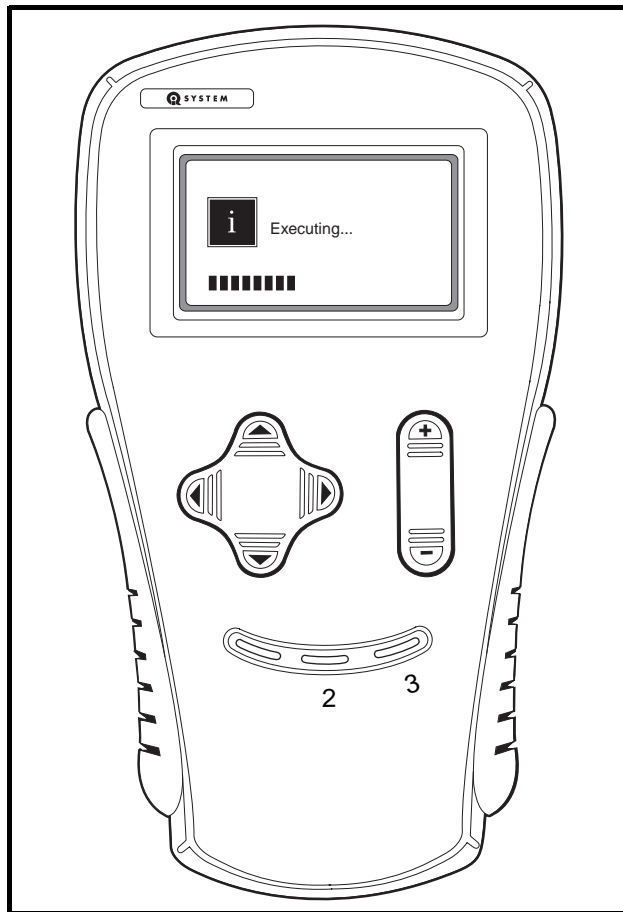


Figure 12-3 Handset Executing

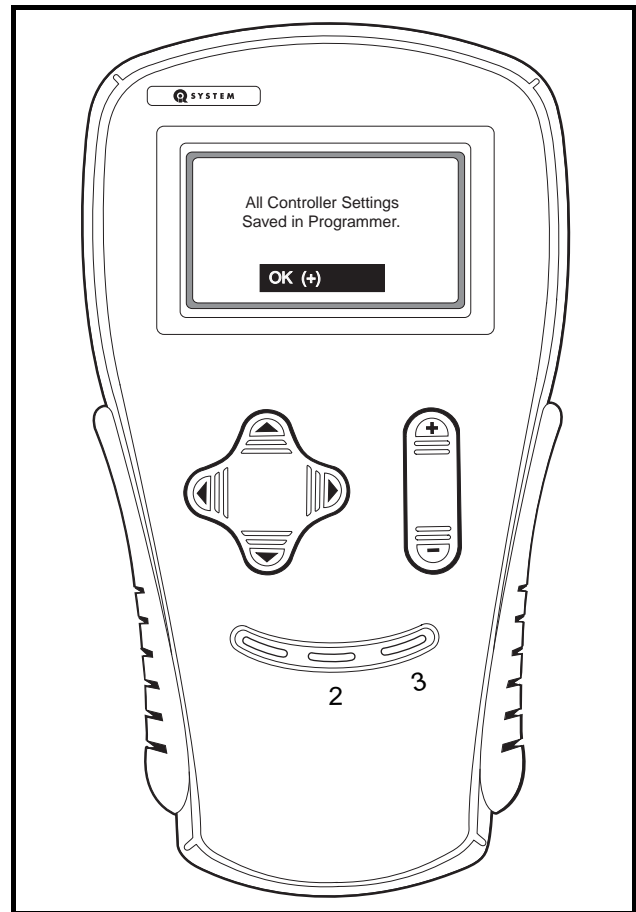


Figure 12-4 Confirmation Message

## WRITE SETTINGS TO CONTROLLER

This function transfers all of the speed controller settings (except for “private speed mode”) from the handset to the vehicle speed controller. This enables the trained technician to “clone” a speed controller. Once the speed controller settings have been transferred to the handset, the technician can then connect the handset to another vehicle and transfer the stored settings into the speed controller.

### Speed Controller Cloning – Transferring Settings from the Handset to the Vehicle

1. Perform this procedure with a handset that has the desired speed controller settings. **See Speed Controller Cloning – Transferring Settings from the Vehicle to the Handset on page 12-10.**
2. Locate a vehicle that does **not** have the desired speed controller settings.

3. Turn the key switch to the OFF position, place the Forward/Reverse handle in the NEUTRAL position, and lock the park brake.
4. Plug the handset into the vehicle.
  - 4.1. Connect one end of the cable to the jack located on the bottom of the handset.
  - 4.2. Connect the cable adaptor to the IQDM cable.
  - 4.3. Remove the dust cap from the IQDM jack.
  - 4.4. Align the keyed portion of the plug with the IQDM jack and connect the plug to the jack (**Figure 12-3** or **Figure 12-4**).
5. Scroll to the *functions* menu and select.
6. Select *settings*.
7. Select *write settings to controller*.
8. Press + on the change value button to confirm the operation.
9. The handset will display an “executing...” message for the next few seconds while the controller settings are being stored in the handset’s memory (**Figure 12-3**).
10. When the handset is finished transferring the speed controller settings, a confirmation message is displayed (**Figure 12-5**).
11. Repeat this procedure for additional vehicles that need to be programmed with the same handset settings.

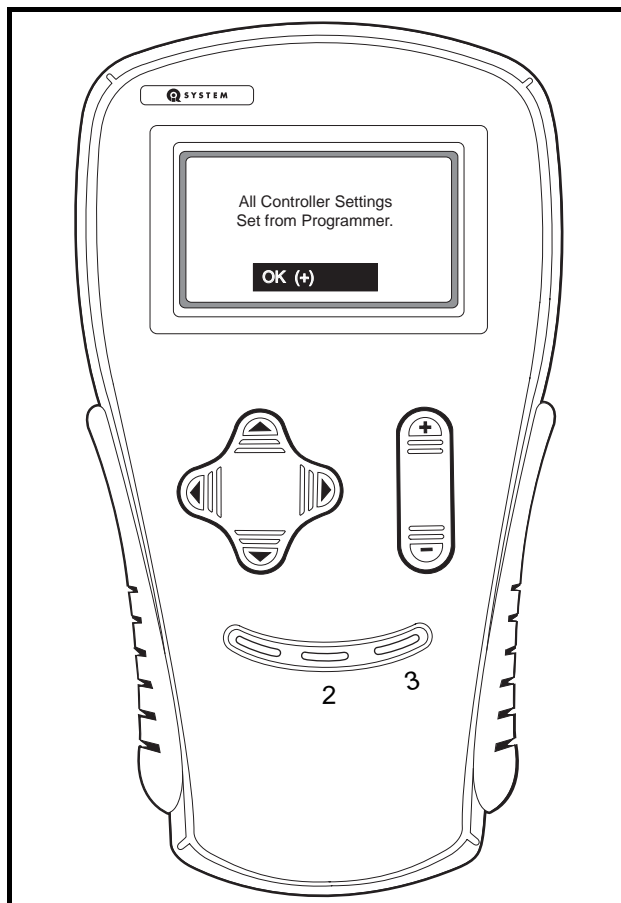


Figure 12-5 Confirmation Message

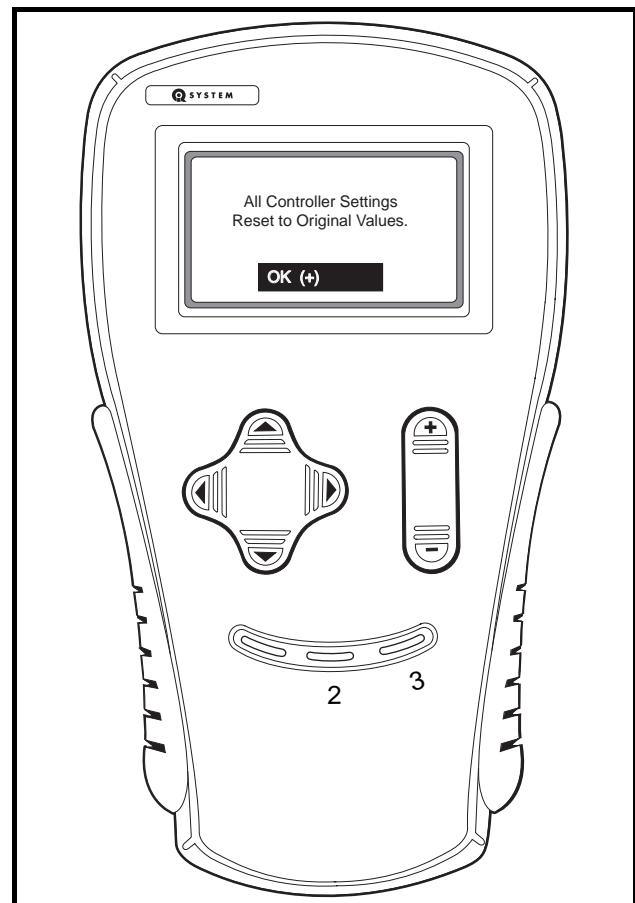


Figure 12-6 Confirmation Message

## RESET ALL SETTINGS

In the event that a mistake was made and one or more changes should not have been made with the handset, the speed controller settings can be reverted to the original settings from the beginning of the session (when the handset was plugged into the vehicle). This function is similar to the “undo” command on a PC and will work correctly only when the handset has **not** been unplugged and power to the speed controller has **not** been interrupted.

### Resetting All Settings

1. During an active session when the settings need to be returned to the original values (the values that were active at the beginning of the session), scroll to the *functions* menu and select.
2. Select *settings*.
3. Select *reset all settings*.
4. Press + on the change value button to confirm the operation.
5. The handset will display an “executing...” message for the next few seconds while the controller settings are being stored in the handset’s memory (**Figure 12-3**).
6. When the handset is finished resetting the speed controller settings, a confirmation message is displayed (**Figure 12-6**).

## INFORMATION

---

The *information* menu is accessed by using the up or down arrow to scroll to *information* and pressing the right arrow key to activate the menu.

This menu selection displays information pertaining to the speed controller. The information provided from this menu selection includes:

### Model Number

Displays the model number of the speed controller.

### Serial Number

Displays the serial number of the speed controller.

### MFG Date

Displays the date the speed controller was manufactured.

### Software Version

Displays the speed controller software version.

## PROGRAMMER SETUP

---

The *programmer setup* menu selection allows the user to set the LCD display contrast, records the fault history of the handset, and displays information pertaining to the handset.

## PROGRAM

This menu allows the user to adjust the contrast on the display screen. After selecting the *LCD-Contrast* menu, use the change value buttons to adjust the contrast for the best readability.

## FAULTS

This menu selection displays faults that have been detected within the handset. This *faults* menu does not pertain to any faults detected in the speed controller.

The following faults can be detected within the handset:

CODE NUMBER	TEXT DISPLAYED
14	Communication error with controller
15	Error in handset
16	Handset does not support this function
17	Serial port overrun error
18	Security lockout on program menu

## Fault History

This menu displays any faults that have been detected within the handset itself.

## Clear Fault History

The *clear fault history* function will erase the history of faults that are stored in the handset.

## INFORMATION

This menu selection displays information pertaining to the handset. The information provided in this menu selection includes model number, serial number, the date the handset was manufactured, the handset software version, etc.



## IQDM AND IQDM-P HANDSET TROUBLESHOOTING

In the event that the handset does not function as described in this manual, the following troubleshooting guide should be studied and the referenced test procedures should be performed to troubleshoot the handset.

<b>TROUBLESHOOTING GUIDE</b>		
<b>SYMPTOM</b>	<b>POSSIBLE CAUSES</b>	<b>CORRECTIVE ACTION</b>
<b>Handset display screen is blank</b>	Handset cord and/or adaptor is disconnected	<b>See Plugging the Handset into the Vehicle on page 1.</b>
	Vehicle batteries – loose terminals or corrosion	<b>See Section 14 – Batteries.</b>
	Vehicle batteries – improperly wired	<b>See Section 14 – Batteries.</b>
	Vehicle batteries – batteries failed	<b>See Section 14 – Batteries.</b>
	Vehicle batteries – batteries not fully charged	<b>See Section 14 – Batteries.</b>
	Handset cord has failed	Test Procedure 1 – Handset Cord on page 12-16
	Handset cord adaptor has failed	Test Procedure 2 – Handset Cord Adaptor on page 12-17
	IQDM jack (on vehicle F&R switch) has failed	Test Procedure 3 – IQDM Jacks on page 12-17
	Contrast Setting is too light	<b>See Program on page 12-14.</b>
	Onboard computer is in power-down mode	Drive the vehicle for a short distance and reconnect the handset to the vehicle.
	Onboard computer malfunction	<b>See Section 11 – Electrical System and Testing.</b>
	Loose vehicle wire harness connections	Test Procedure 3 – IQDM Jacks on page 12-17
	Speed controller malfunction	<b>See Section 11 – Electrical System and Testing.</b>
	Handset has failed	Replace handset
<b>Display screen shows jumbled or undecipherable characters</b>	Speed controller malfunction	<b>See Section 11 – Electrical System and Testing.</b>
	Handset malfunction	Disconnect the IQDM cord from the vehicle. Wait a few seconds and reconnect the handset to the vehicle
	Loose connection at IQDM jack	Test Procedure 3 – IQDM Jacks on page 12-17
	Intermittent handset cord failure	Test Procedure 1 – Handset Cord on page 12-16
	Intermittent handset cord adaptor failure	Test Procedure 2 – Handset Cord Adaptor on page 12-17
	Loose vehicle wire harness connections	Test Procedure 3 – IQDM Jacks on page 12-17
<b>Troubleshooting Guide continued on next page...</b>		

## TROUBLESHOOTING GUIDE

SYMPTOM	POSSIBLE CAUSES	CORRECTIVE ACTION
Handset is “locked-up” – buttons do not respond	Handset malfunction	Disconnect the IQDM cord from the vehicle. Wait a few seconds and reconnect the handset to the vehicle
	Vehicle batteries – loose terminals or corrosion	<b>See Section 14 – Batteries.</b>
	Vehicle batteries – improperly wired	<b>See Section 14 – Batteries.</b>
	Vehicle batteries – batteries failed	<b>See Section 14 – Batteries.</b>
	Vehicle batteries – batteries not fully charged	<b>See Section 14 – Batteries.</b>
	Speed controller malfunction	<b>See Section 11 – Electrical System and Testing.</b>

## TEST PROCEDURES

The following test procedures enable the technician to test the IQDM and IQDM-P handsets and the components of the IQ System vehicle that are related to the proper operation of the handset.

### **⚠ WARNING**

- If wires are removed or replaced, make sure wiring and wire harness is properly routed and secured. Failure to properly route and secure wiring could result in vehicle malfunction, property damage, personal injury, or death.

## INDEX OF TEST PROCEDURES

1. Handset Cord
2. Handset Cord Adaptor
3. IQDM Jacks

## TEST PROCEDURE 1 – HANDSET CORD

**See General Warning, Section 10, Page 10-1.**

1. Using a multimeter set for 200 ohms, place the red (+) probe into one of the terminals on the end of the cord with the square plug.
2. Place the black (–) probe on each of the pins, one at a time, on the plug on the other end of the cord.
3. The multimeter should indicate continuity on only one pin. If any other reading is obtained, the cord must be replaced.
4. Repeat the procedure three more times, each time with the red (+) probe inserted into a different terminal on the end of the cord with the square plug.

## TEST PROCEDURE 2 – HANDSET CORD ADAPTOR

### See General Warning, Section 10, Page 10-1.

The procedure for testing the handset cord adaptor is similar to the cord test.

1. Using a multimeter set for 200 ohms, place the red (+) probe into one of the terminals on the end of the adaptor with the square plug.
2. Place the black (–) probe on each of the pins, one at a time, on the other plug of the adaptor.
3. The multimeter should indicate continuity on only one pin. If any other reading is obtained, the adaptor must be replaced.
4. Repeat the procedure three more times, each time with the red (+) probe inserted into a different terminal on the end of the adaptor with the square plug.

## TEST PROCEDURE 3 – IQDM JACKS

Inspect the IQDM jacks for damage or corrosion.

### Test Procedure 3A – IQDM JACKS (LOCATED ON F&R SWITCH AND ON THE SPEED CONTROLLER)

#### See General Warning, Section 10, Page 10-1.

1. Turn the key switch to the OFF position, place the Forward/Reverse handle in the NEUTRAL position, and lock the park brake.
2. Place the Tow/Run switch in the TOW position, disconnect the batteries, negative (–) cable first, and wait 90 seconds for the speed controller capacitors to discharge. **See WARNING on page 10-1.**
3. Check the IQDM jack at the Forward/Reverse switch case.
  - 3.1. Remove the three self-tapping screws that hold the F&R rocker switch case (2) to the body (Figure 12-7, Page 12-17).

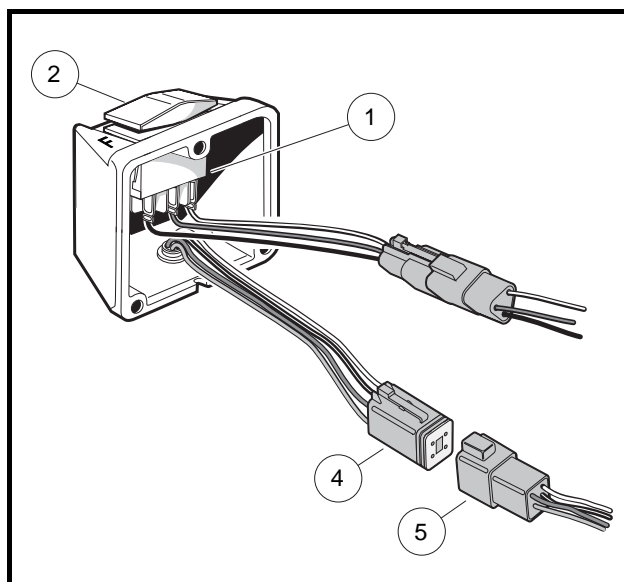


Figure 12-7 Forward/Reverse Rocker Switch With IQDM Jack

- 3.2. Disconnect the four-pin connectors (4 and 5) and visually inspect the contacts for damage and corrosion. Inspect the IQDM jack, located on the bottom of the switch case (2). Repair and replace parts as necessary.
- 3.3. If no problem is found, connect the four-pin connectors and install the F&R switch case.
- 3.4. Install the three self-tapping screws that hold the F&R rocker switch case (2) to the body. Tighten to 20 in-lb (2.2 N·m).
4. Check the IQDM jack on the speed controller.
  - 4.1. Remove the two screws securing the rear body access panel and remove the access panel.
  - 4.2. Remove the two screws (5) securing the controller cover (1) to the component mounting plate (**Figure 12-8**).
  - 4.3. Disconnect the square four-pin connector (3) from the speed controller.
  - 4.4. Connect the handset cord to the handset.
  - 4.5. Connect the other end of the handset cord (without the adapter) (4) to the four-pin connector of the speed controller (2) (**Figure 12-8**).
  - 4.6. Connect the vehicle batteries, positive (+) cable first.
  - 4.7. If the handset functions when connected directly to the speed controller, the adapter plug or vehicle wire harness should be thoroughly tested. **See Test Procedure 2 – Handset Cord Adaptor on page 12-17. See also See Section 11 – Electrical System and Testing.**

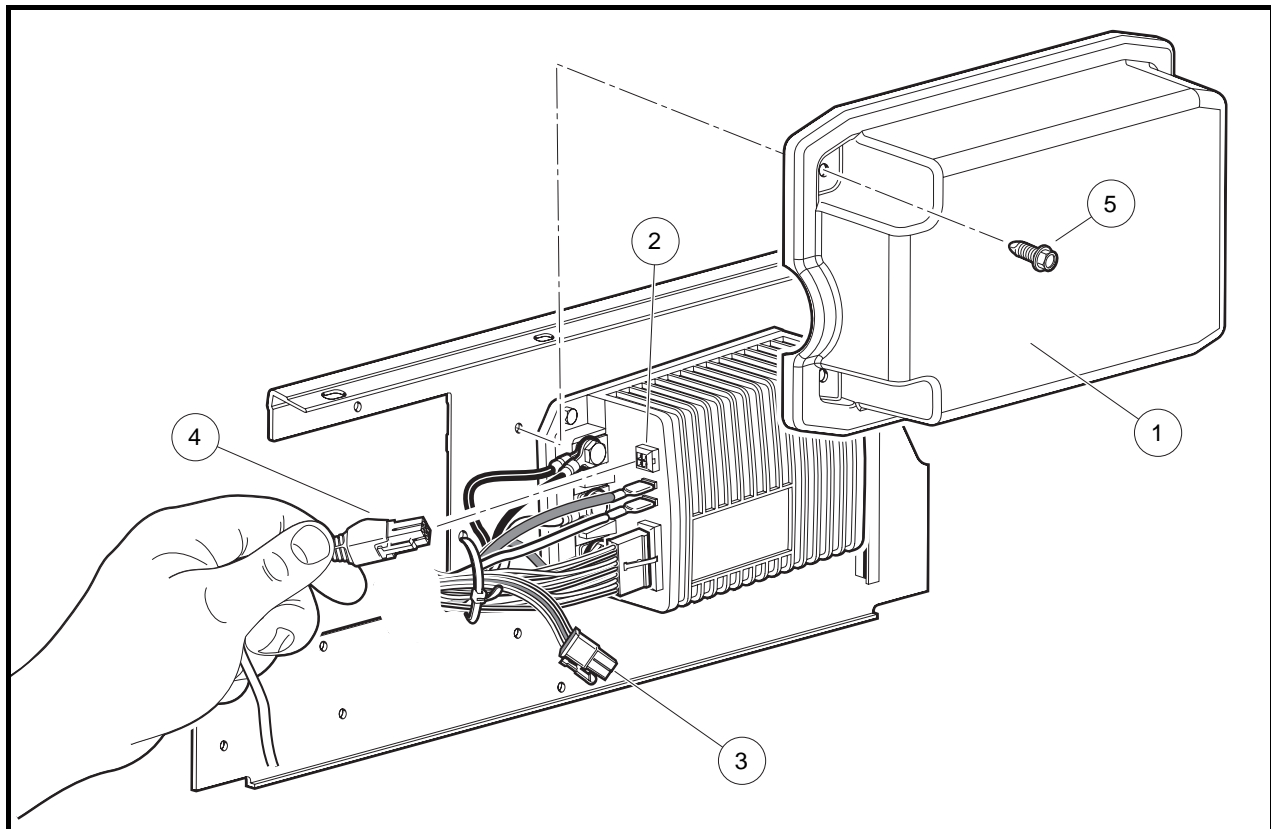


Figure 12-8 IQ System Component Mounting Plate

## SECTION 13 – ELECTRICAL COMPONENTS

### **⚠ DANGER**

- See General Warning, Section 10, Page 10-1.

### **⚠ WARNING**

- See General Warning, Section 10, Page 10-1.

## KEY SWITCH

See General Warning, Section 10, Page 10-1.

### Testing the Key Switch

See Test Procedure 8, Section 11, Page 11-23.

### Key Switch Removal

1. Disconnect the battery cables as instructed. **See WARNING "To avoid unintentionally starting..." in General Warning, Section 10, Page 10-1.**
2. Remove the center dash panel (**Figure 13-1, Page 13-1**).
  - 2.1. Remove the plastic cap (1) covering the mounting screw (2) on each side of the center dash panel (3) (**Figure 13-1, Page 13-1**).
  - 2.2. Loosen, but do not remove, the screw (2) on each side of the center dash panel (3).
  - 2.3. Insert screwdriver at the top center of the dash between dash and cowl brace. Gently pry center dash out slightly from under edge of cowl brace.

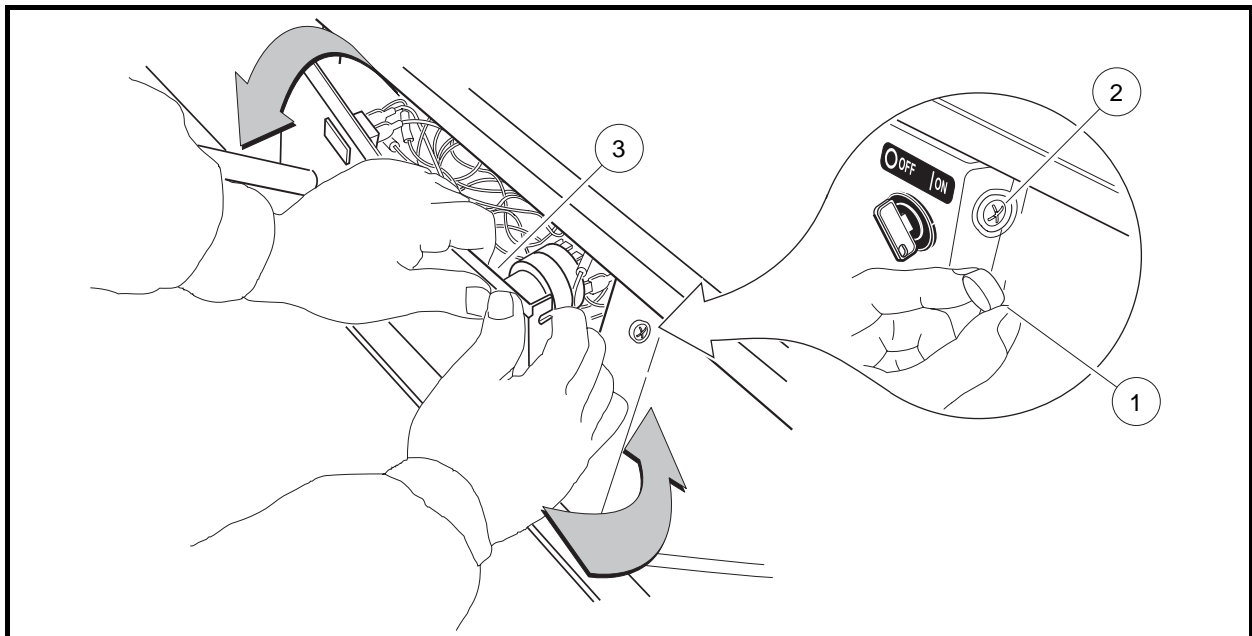


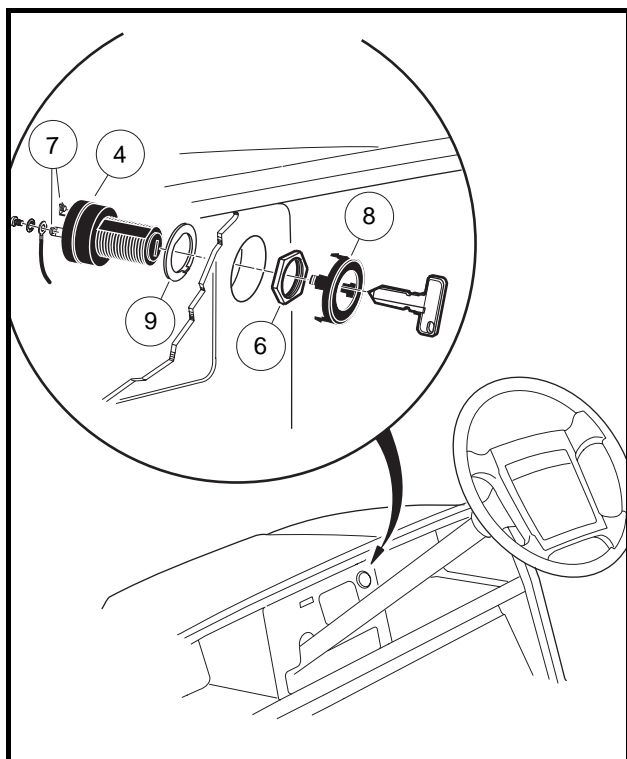
Figure 13-1 Dash Removal

**Key Switch Removal, Continued:**

- 2.4. Pull center dash out approximately 1 inch (2.5 cm) from the frame and then bend the top right corner of the center dash inward while pulling the top of the panel out and down.

**NOTE:** Bending the top right corner of the center dash inward during removal will prevent the terminals (7) on the back of the key switch from touching the metal frame around the dash (**Figure 13-2, Page 13-2**).

3. Slide center dash panel up steering column by snapping top out and then rotating the panel out and up.
4. Disconnect the wires from the key switch. Do not allow wires to touch.
5. From the back of the dash panel, push down on the retaining tabs surrounding the key switch (4) and remove the key switch cap (8). Hold the key switch and remove the switch retaining nut (6) from the outside of the dash panel (**Figure 13-2, Page 13-2**).



**Figure 13-2 Key Switch**

**Key Switch Installation**

1. Position the key switch and flat washer (9) in the center dash, then install and tighten the switch retaining nut (6) to 40 in-lb (4.5 N·m). Install key switch cap (8) in center dash (**Figure 13-2, Page 13-2**).
2. Using the wiring diagram, connect the wires to the key switch terminals and tighten the terminal screws to 7 in-lb (0.8 N·m). **See Wiring Diagram, Section 11, Page 11-10.** Coat the terminals with Battery Terminal Protector Spray (CCI P/N 1014305).
3. Install center dash by reversing removal procedure. Make sure key switch terminals (7) do not touch frame and that the center dash panel is properly seated and snapped into place (**Figure 13-2, Page 13-2**).

4. Place the Tow/Run switch in the TOW position and connect the battery cables, positive (+) cable first. Tighten battery terminals to 110 in-lb (12.4 N·m) and coat terminals with Battery Terminal Protector Spray (CCI P/N 1014305) to minimize corrosion.

---

## FORWARD/REVERSE ROCKER SWITCH

---

**See General Warning, Section 10, Page 10-1.**

### Testing the Forward/Reverse Rocker Switch

**See Test Procedure 15, Section 11, Page 11-38.**

### Forward/Reverse Rocker Switch Removal

1. Disconnect the battery cables as instructed. **See WARNING "To avoid unintentionally starting..." in General Warning, Section 10, Page 10-1.**
1. Remove three self-tapping screws (3) that hold Forward/Reverse rocker switch case (2) to body (**Figure 13-3, Page 13-4**).
2. Remove the 18-gauge brown, orange, and blue wires from the rocker switch.
3. Press the locking tabs (11) on each end of switch and push switch out of case.

### Forward/Reverse Rocker Switch Installation

1. Press the locking tabs (11) on each end of the rocker switch and push switch into case (**Figure 13-3, Page 13-4**).
2. Connect the 18-gauge brown, orange, and blue wires to the rocker switch exactly as shown in the wiring diagram. **See Wiring Diagram, Section 11, Page 11-10.**
3. Install the three self-tapping screws (3) that hold the Forward/Reverse rocker switch case (2) to the body. Tighten to 20 in-lb (2.3 N·m).
4. Place the Tow/Run switch in the TOW position and connect the battery cables, positive (+) cable first. Tighten battery terminals to 110 in-lb (12.4 N·m) and coat terminals with Battery Terminal Protector Spray (CCI P/N 1014305) to minimize corrosion.
5. Place the Tow/Run switch in the RUN position.
6. Inspect the vehicle for proper operation.
  - Make sure that the vehicle operates in the forward direction when the Forward/Reverse switch is in the FORWARD position.
  - Make sure that the vehicle operates in the reverse direction when the Forward/Reverse switch is in the REVERSE position. The reverse buzzer will sound as a warning when the Forward/Reverse switch is in REVERSE.
  - Make sure that the vehicle does not operate when the Forward/Reverse switch is in the NEUTRAL position.

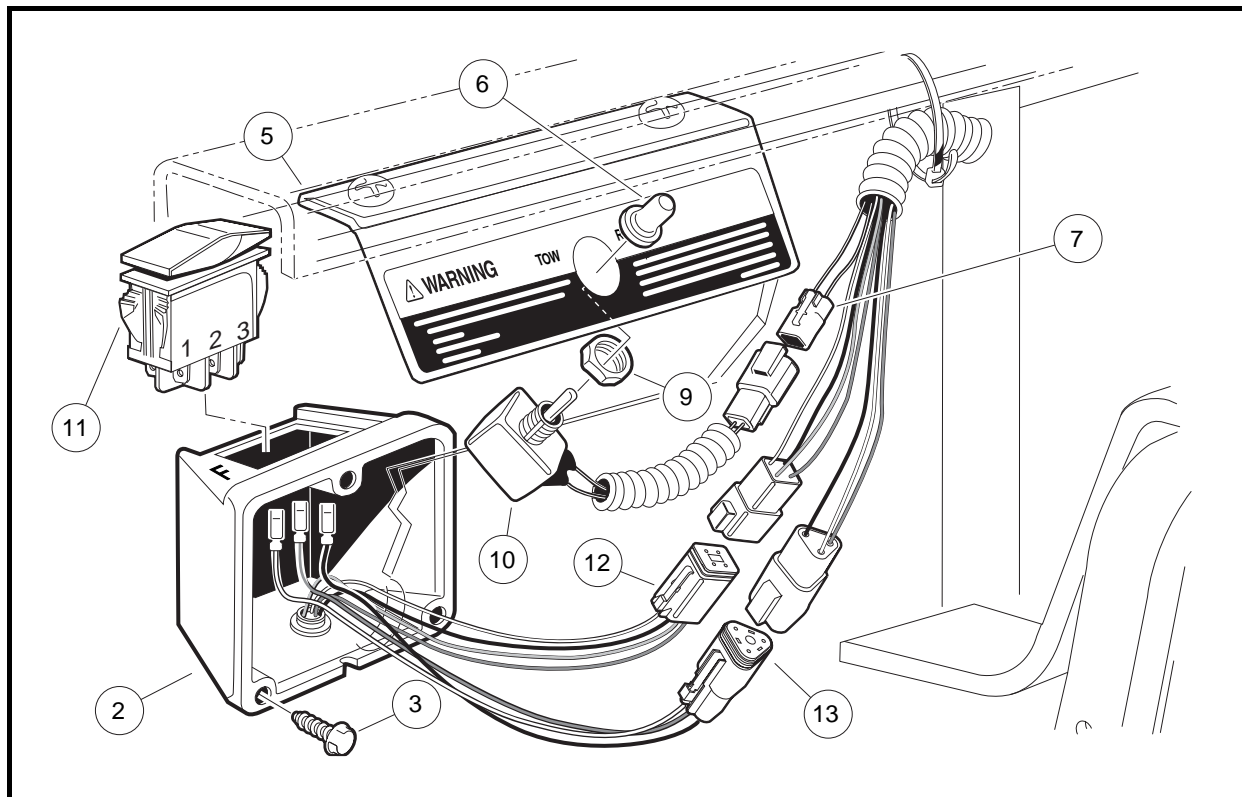


Figure 13-3 Tow/Run Switch and Forward/Reverse Rocker Switch

## TOW/RUN SWITCH

See General Warning, Section 10, Page 10-1.

### Testing the Tow/Run Switch

See Test Procedure 6, Section 11, Page 11-22.

### Tow/Run Switch Removal

1. Disconnect the battery cables as instructed. **See WARNING "To avoid unintentionally starting..." in General Warning, Section 10, Page 10-1.**
2. Remove Tow/Run switch boot/hex nut (6) (**Figure 13-3, Page 13-4**).
3. Remove Tow/Run switch (10) and nut (9) from bracket (5).
4. Disconnect the two-pin connector (7) and remove switch.

### Tow/Run Switch Installation

1. Installation is reverse of removal. Make sure groove on switch is aligned with tang on bracket. Tighten Tow/Run switch boot/hex nut (6) to 16 in-lb (1.8 N-m) (**Figure 13-3, Page 13-4**).
2. Place the Tow/Run switch in the TOW position and connect the battery cables, positive (+) cable first. Tighten battery terminals to 110 in-lb (12.4 N-m) and coat terminals with Battery Terminal Protector Spray (CCI P/N 1014305) to minimize corrosion.



## MOTOR CONTROLLER OUTPUT REGULATOR (MCOR)

See General Warning, Section 10, Page 10-1.

### Testing the MCOR

See Section 11, Test Procedure 4, Page 11-20 and Test Procedure 8, Page 11-23.

### MCOR Removal

1. Disconnect the battery cables as instructed. **See WARNING "To avoid unintentionally starting..." in General Warning, Section 10, Page 10-1.**
2. Place chocks at rear wheels and lift the front of the vehicle with a chain hoist or floor jack. Place jack stands under the round tube crossmember of the frame to support vehicle.
3. Disconnect the two-pin and three-pin connectors (1) from the MCOR (2) (**Figure 13-4, Page 13-5**).
4. Remove the hex-head screws (3) connecting the MCOR to the frame I-beam.
5. Remove the MCOR from vehicle.
6. Push the drive bar (4) into the hole in the I-beam to disengage it from the accelerator pivot rod (5).

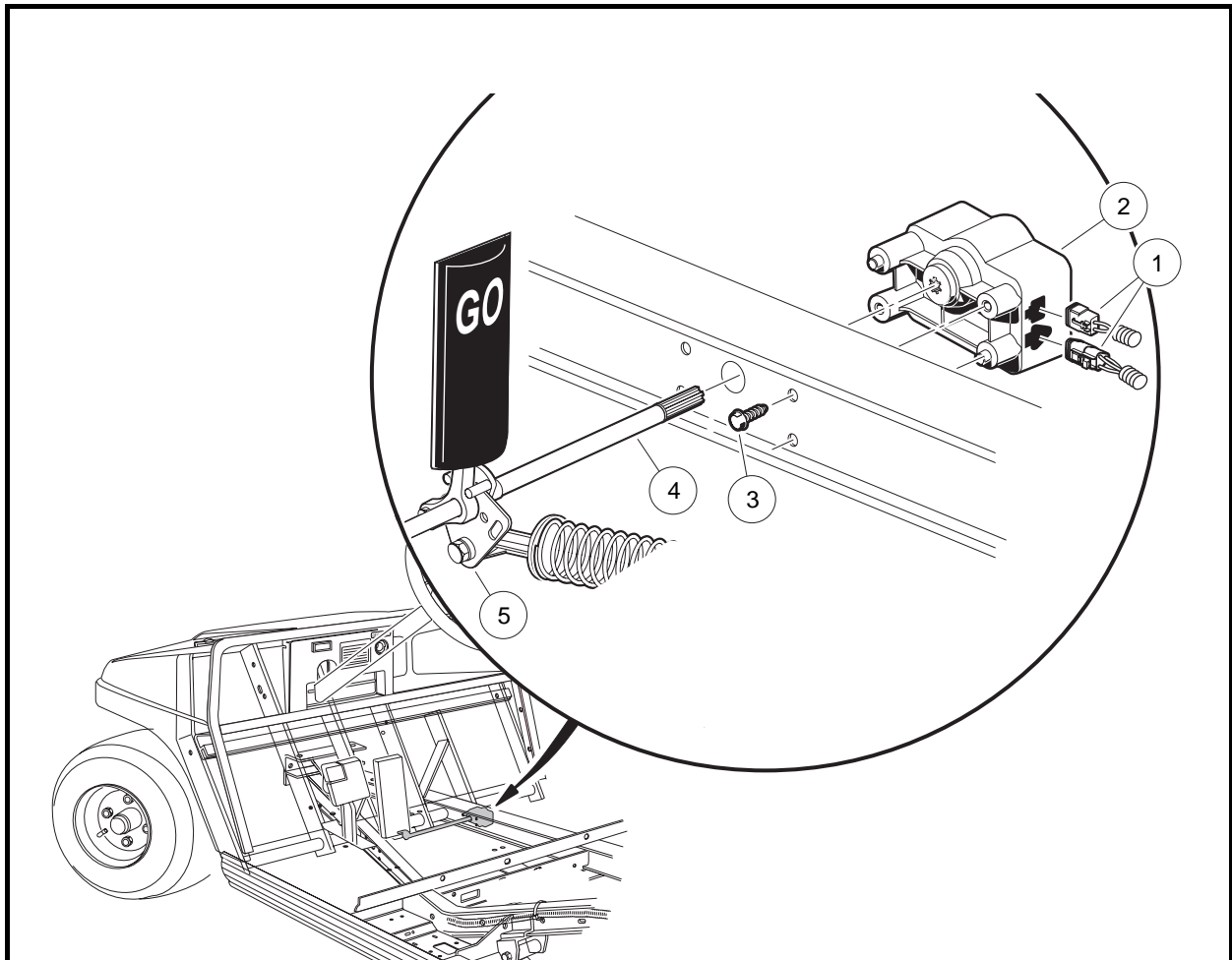


Figure 13-4 Motor Controller Output Regulator (MCOR) Mounting

## MCOR Installation

1. Insert the splined end of the drive bar (4) through the hole in the passenger-side frame I-beam as shown (**Figure 13-4, Page 13-5**).
2. Position the opposite end of the drive bar so that the accelerator pedal sits between the two pins.
3. Place the MCOR (2) onto the splined end of the drive bar (**Figure 13-4, Page 13-5**). See following **NOTE**.

**NOTE:** The MCOR is keyed to ensure correct positioning on the drive bar.

4. Insert the alignment pins on the MCOR into the holes in the I-beam as shown.
5. Secure the MCOR to the frame I-beam with two hex-head screws (3). Tighten screws to 23 in-lb (2.6 N·m).
6. Connect the two-pin and three-pin connectors (1) from the wire harness to the MCOR.
7. Place the Tow/Run switch in the TOW position and connect the battery cables, positive (+) cable first. Tighten battery terminals to 110 in-lb (12.4 N·m) and coat terminals with Battery Terminal Protector Spray (CCI P/N 1014305) to minimize corrosion.

## REVERSE BUZZER

---

See **General Warning, Section 10, Page 10-1**.

### Testing the Reverse Buzzer

See **Test Procedure 16, Section 11, Page 11-39**.

### Reverse Buzzer Removal

1. Disconnect the battery cables as instructed. See **WARNING "To avoid unintentionally starting..." in General Warning, Section 10, Page 10-1**.
2. Remove center dash. See **step 2 of Key Switch Removal on page 13-1**.
3. Disconnect the 18-gauge red and orange/white wires from reverse buzzer.
4. Remove the two screws from the reverse buzzer. Remove the reverse buzzer from the center dash panel.

### Reverse Buzzer Installation

1. Install the reverse buzzer in the reverse order of removal. Tighten screws to 4 in-lb (0.45 N·m).
2. Place the Tow/Run switch in the TOW position and connect the battery cables, positive (+) cable first. Tighten battery terminals to 110 in-lb (12.4 N·m) and coat terminals with Battery Terminal Protector Spray (CCI P/N 1014305) to minimize corrosion.

## SOLENOID

---

See **General Warning, Section 10, Page 10-1**.

The solenoid is located on the driver side of the electrical component mounting plate.

### Testing the Solenoid

See **Section 11, Test Procedure 3, Page 11-18 and Test Procedure 14, Page 11-37**.

## Solenoid Removal

1. Disconnect the battery cables as instructed. **See WARNING "To avoid unintentionally starting..." in General Warning, Section 10, Page 10-1.**
2. Remove the rear body access panel.
3. Disconnect all wires from the solenoid (3) (**Figure 13-5, Page 13-7**).
4. Loosen, but do not remove, the two screws (12) that hold the solenoid (3) to the component mounting plate.
5. Lift the solenoid (3) up and off of the component mounting plate.

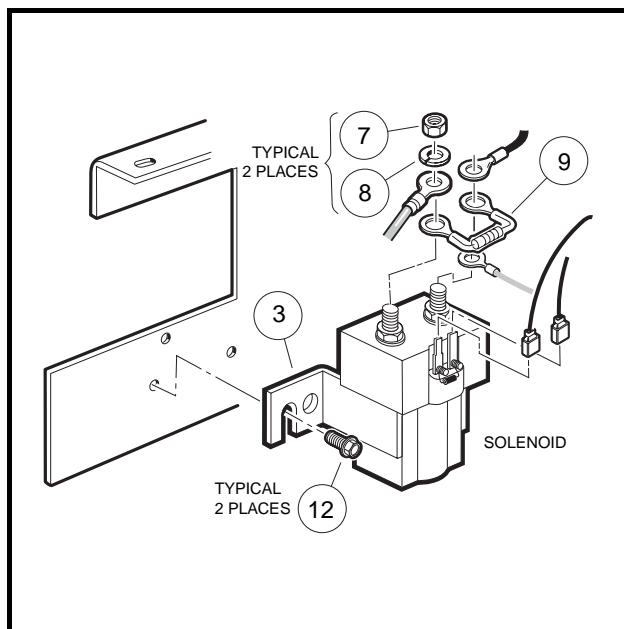


Figure 13-5 Solenoid

## Solenoid Installation

1. Mount solenoid (3) onto component mounting plate with screws (12) (**Figure 13-5, Page 13-7**).
2. Tighten screws (12) to 60 in-lb (6.8 N·m).
3. Using the wiring diagram, install the wires, resistor (9), washers (8), and nuts (7) onto the large mounting posts. Tighten nuts to 77 in-lb (8.7 N·m). **See Wiring Diagram, Section 11, Page 11-10.**
4. Install the blue/white and light blue wires onto the small terminals of the solenoid (**Figure 13-5, Page 13-7**).
5. Install rear body access panel.
6. Place the Tow/Run switch in the TOW position and connect the battery cables, positive (+) cable first. Tighten battery terminals to 110 in-lb (12.4 N·m) and coat terminals with Battery Terminal Protector Spray (CCI P/N 1014305) to minimize corrosion.

## ONBOARD COMPUTER (OBC)

See General Warning, Section 10, Page 10-1.

### Testing the Onboard Computer

See Section 11, Test Procedure 2, Page 11-17, Test Procedure 10, Page 11-35, and Test Procedure 11, Page 11-35.

### Onboard Computer Removal

1. Disconnect the battery cables as instructed. See **WARNING "To avoid unintentionally starting..."** in **General Warning, Section 10, Page 10-1**.
2. Remove rear body access panel and unplug the six-pin connector (16) at the OBC (**Figure 13-6, Page 13-8**).

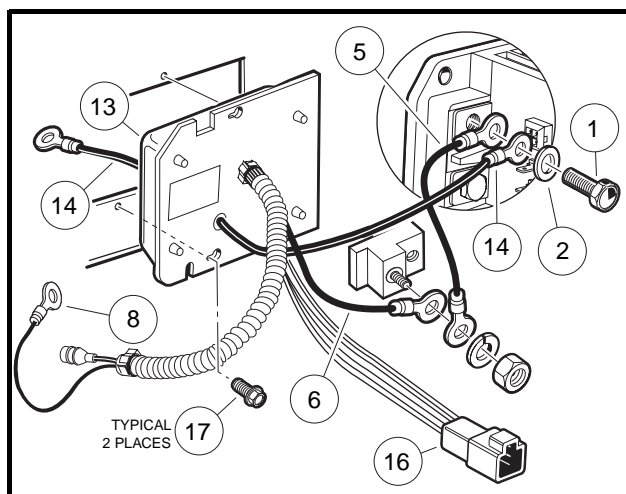


Figure 13-6 Onboard Computer

3. Remove the two screws (5) from the speed controller cover (1) and remove the cover (**Figure 13-7, Page 13-9**).
4. Remove the wire tie (3) securing the speed controller wires to the mounting plate.
5. Remove black 6-gauge wire (14) and black 10-gauge wire (5) from the speed controller B- terminal (**Figure 13-6, Page 13-8**).
6. Remove the black 10-gauge wire (6) from the accessory mounting terminal.
7. Disconnect the gray wire fuse holder at the charger receptacle.
8. Disconnect the black 10-gauge wire (8) at the charger receptacle.
9. Cut the wire tie that secures the OBC wire harness to the I-beam.
10. Loosen, but do not remove, the two self-tapping screws (17) holding OBC to component mounting plate.
11. Slide OBC towards outside of vehicle and align heads of self-tapping screws (17) with the two holes in the OBC face plate. Pull OBC towards rear of vehicle and remove from component mounting plate.

### Onboard Computer Installation

1. Disconnect the battery cables as instructed. See **WARNING "To avoid unintentionally starting..."** in **General Warning, Section 10, Page 10-1**.

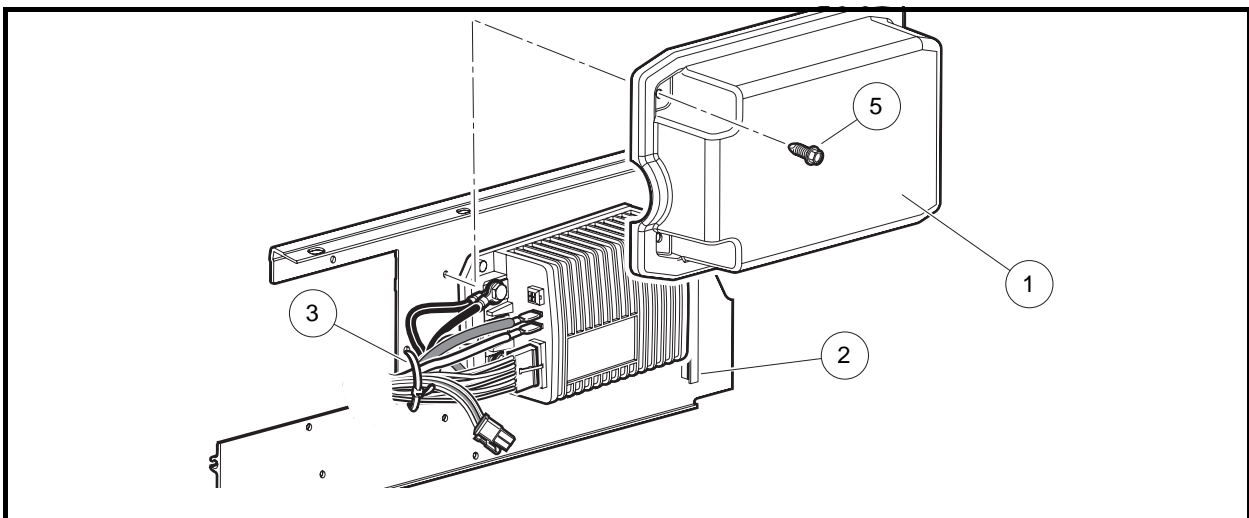
2. Remove the rear body access panel.
3. Install the OBC onto the component mounting plate by aligning the two holes on the OBC face plate with two holes on component mounting plate. Slide OBC towards inside of vehicle and align heads of self-tapping screws (17) with smaller part of two holes in OBC face plate (**Figure 13-6, Page 13-8**). Tighten screws to 60 in-lb (6.7 N-m). **See following NOTE.**

**NOTE:** The aluminum plate on the OBC should face toward the rear of the vehicle. The white potting material side of the OBC should face toward the front of the vehicle.

4. Attach wire tie so the OBC wire harness is secured to the I-beam.
5. Connect the black 10-gauge wire (8) to the charger receptacle (**Figure 13-6, Page 13-8**). Tighten to 23 in-lb (2.6 N-m).
6. Connect the gray wire fuse holder to the charger receptacle.
7. Connect the black 10-gauge wire (6) to the accessory mounting terminal. Install the nut on the accessory terminal and tighten to 9 ft-lb (12.2 N-m).
8. Connect the black 6-gauge wire (14) and black 10-gauge wire (5) to the speed controller B- terminal with the washer (2) and bolt (1) and tighten to 9 ft-lb (12.2 N-m) (**Figure 13-6, Page 13-8**).
9. Plug the six-pin connector (16) from the OBC into the vehicle wire harness.
10. Install a wire tie (3) to tightly secure the speed controller wires to the component mounting plate (**Figure 13-7, Page 13-9**).
11. Place the edge of the speed controller cover (1) into the slot (2). Press the controller cover onto the component mounting plate over the speed controller and install the two screws (5) (**Figure 13-7, Page 13-9**). Tighten the screws (5) to 60 in-lb (6.8 N-m). **See following NOTE.**

**NOTE:** Make sure that the speed controller cover gasket forms a tight seal between the cover and the component mounting plate.

12. Install rear body access panel.
13. Place the Tow/Run switch in the TOW position and connect the battery cables, positive (+) cable first. Tighten battery terminals to 110 in-lb (12.4 N-m) and coat terminals with Battery Terminal Protector Spray (CCI P/N 1014305) to minimize corrosion.



**Figure 13-7 Speed Controller Cover**

## SOLID STATE SPEED CONTROLLER

See General Warning, Section 10, Page 10-1.

### Testing the Solid State Speed Controller

See Test Procedure 5, Section 11, Page 11-21.

### Speed Controller Removal

1. Disconnect the battery cables as instructed. See **WARNING "To avoid unintentionally starting..."** in **General Warning, Section 10, Page 10-1.**
2. Remove the rear body access panel.
3. Remove the two screws (5) from the speed controller cover (1) and remove the cover (**Figure 13-7, Page 13-9**).
4. Disconnect all wires and multi-pin connectors from the speed controller (**Figure 13-8, Page 13-10**).
5. Remove the three self-tapping screws (17) that hold the controller (6) to the component mounting plate and remove the controller from the vehicle.

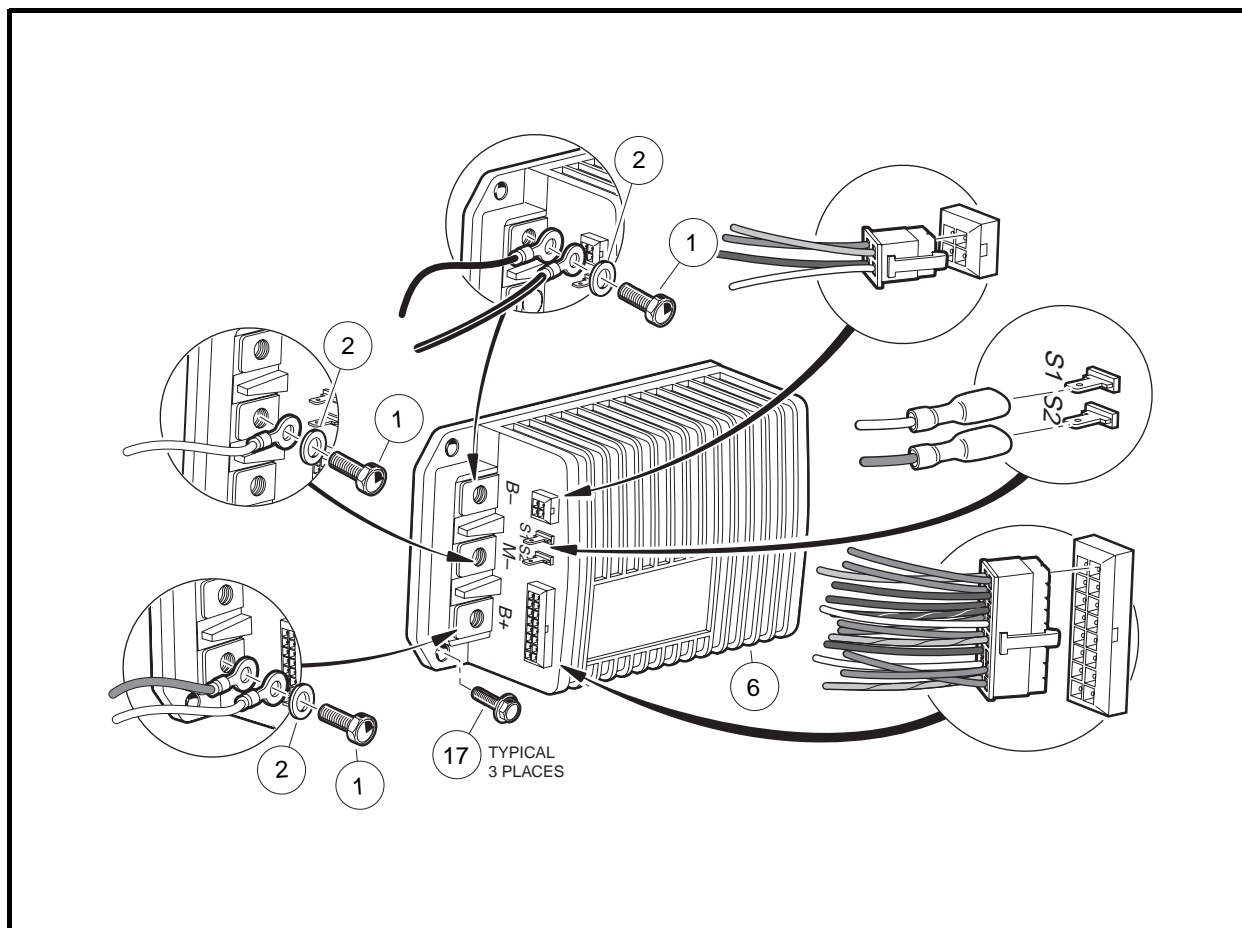


Figure 13-8 Speed Controller

## Speed Controller Installation

1. Install the three self-tapping screws (17) that hold the controller (6) to the component mounting plate and tighten to 60 in-lb (6.8 N-m) (**Figure 13-8, Page 13-10**).
2. Using the wiring diagram, install the multi-pin connectors and all wires as illustrated. **See Wiring Diagram, Section 11, Page 11-10**. Tighten bolts (1) to 9 ft-lb (12.2 N-m) (**Figure 13-8, Page 13-10**).
3. Place the edge of the speed controller cover (1) into the slot (2). Press the controller cover onto the component mounting plate over the speed controller and install the two screws (5) (**Figure 13-7, Page 13-9**). Tighten the screws (5) to 60 in-lb (6.8 N-m). **See following NOTE**.

**NOTE:** Make sure that the speed controller cover gasket forms a tight seal between the cover and the component mounting plate.

4. Install rear body access panel.
5. Place the Tow/Run switch in the TOW position and connect the battery cables, positive (+) cable first. Tighten battery terminals to 110 in-lb (12.4 N-m) and coat terminals with Battery Terminal Protector Spray (CCI P/N 1014305) to minimize corrosion.
6. Place the Tow/Run switch in the RUN position.
7. Inspect the vehicle for proper operation.
  - Make sure that the vehicle operates in the forward direction when the Forward/Reverse switch is in the FORWARD position.
  - Make sure that the vehicle operates in the reverse direction when the Forward/Reverse switch is in the REVERSE position. The reverse buzzer will sound as a warning when the Forward/Reverse switch is in REVERSE.
  - Make sure that the vehicle does not operate when the Forward/Reverse switch is in the NEUTRAL position.

## CHARGER RECEPTACLE

**See General Warning, Section 10, Page 10-1.**

The charger cord, plug, and receptacle are wear items and should be inspected daily. Visually inspect them for cracks, loose connections, and frayed wiring; they must be replaced when worn or damaged. If charger plug or receptacle show signs of corrosion or the plug is difficult to insert or remove, the receptacle contacts and plug terminals should be cleaned with a good electrical contact cleaner or lightly sprayed with WD-40® brand spray lubricant. The plug should then be inserted and removed several times to ensure ease of insertion, ease of removal, and good electrical contact.

### Testing the Charger Receptacle

**See Test Procedure 12, Section 11, Page 11-35.**

**See also the appropriate battery charger maintenance and service manual.**

### Charger Receptacle Inspection

Inspect the receptacle for cracks, loose connections and frayed wiring.

**NOTE:** Disassembly of the charger receptacle, for the purpose of removal or installation, is not recommended.

## Charger Receptacle Removal

1. Disconnect the battery cables as instructed. **See WARNING "To avoid unintentionally starting..." in General Warning, Section 10, Page 10-1.**
2. Remove the 10-gauge red wire (4) from the positive post of battery no. 1 (**Figure 13-9, Page 13-12**).
3. Remove black 10-gauge OBC wire (5) from charger receptacle.
4. Disconnect the gray wire (9) from the receptacle at the yellow fuse holder.
5. Remove the four screws (1) that secure the charger receptacle bezel (7) to the receptacle backing plate (8) and to the vehicle body.
6. Move the receptacle assembly toward the front of the vehicle and tilt receptacle upwards in order for the receptacle to pass through the hole in the vehicle body.

## Charger Receptacle Installation

1. Insert the 10-gauge red wire (4) and the 18-gauge gray wire (3) through the hole in the vehicle body and the receptacle backing plate (**Figure 13-9, Page 13-12**).
2. Insert receptacle into vehicle body.
3. Install the four screws (1) that secure the receptacle to the vehicle body and receptacle backing plate (8). Tighten screws to 16 in-lb (1.8 N·m).
4. Connect 18-gauge gray wire (9) to yellow fuse holder. Make sure fuse (11) is installed in fuse holder.
5. Connect the 10-gauge black wire (5) to the receptacle fuse link (6) on the charger receptacle (**Figure 13-9, Page 13-12**). Tighten to 23 in-lb (2.6 N·m).
6. Connect the 10-gauge red wire (4) to the positive post of battery no. 1.
7. Place the Tow/Run switch in the TOW position and connect the battery cables, positive (+) cable first. Tighten battery terminals to 110 in-lb (12.4 N·m) and coat terminals with Battery Terminal Protector Spray (CCI P/N 1014305) to minimize corrosion.

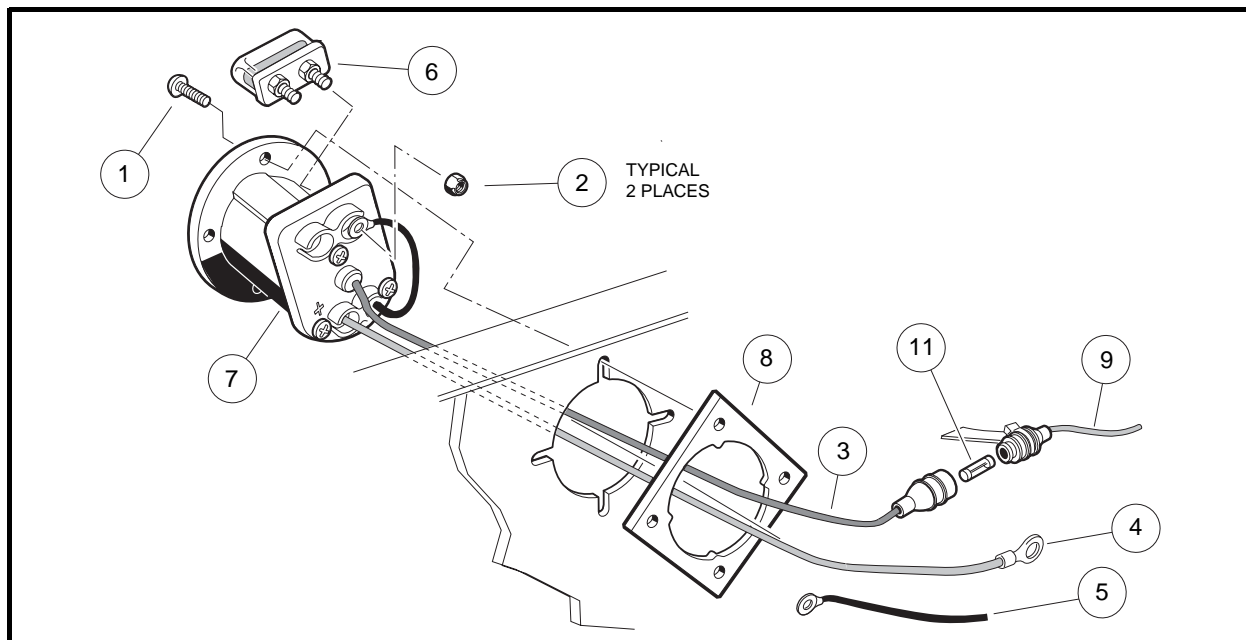


Figure 13-9 Charger Receptacle



## RECEPTACLE FUSE LINK

The fuse link on the 48-volt Club Car electric vehicle should not blow under normal operating conditions; however, if the fuse link has blown, the vehicle will not charge and the fuse must be replaced. The fuse link (6) is mounted on top of the charger receptacle in the battery compartment (**Figure 13-9, Page 13-12**).

### Receptacle Fuse Link Removal

1. Remove the fuse link (6) from the charger receptacle (7) by removing the two nuts and washers used to secure the 10-gauge black wire from the computer (5) and the 10-gauge black wire to the receptacle (**Figure 13-9, Page 13-12**).
2. Remove the fuse link (6) from the charger receptacle.

### Receptacle Fuse Link Installation

1. Insert the two fuse link mounting posts into the mounting holes in the charger receptacle.
2. Place the two 10-gauge black wires in their original positions on the fuse link mounting posts. Tighten to 23 in-lb (2.6 N·m).
3. Install nuts (2) on fuse link mounting posts and tighten to 23 in-lb (2.6 N·m) (**Figure 13-9, Page 13-12**).

## BATTERY WARNING LIGHT

---

See General Warning, Section 10, Page 10-1.

### Testing the Battery Warning Light

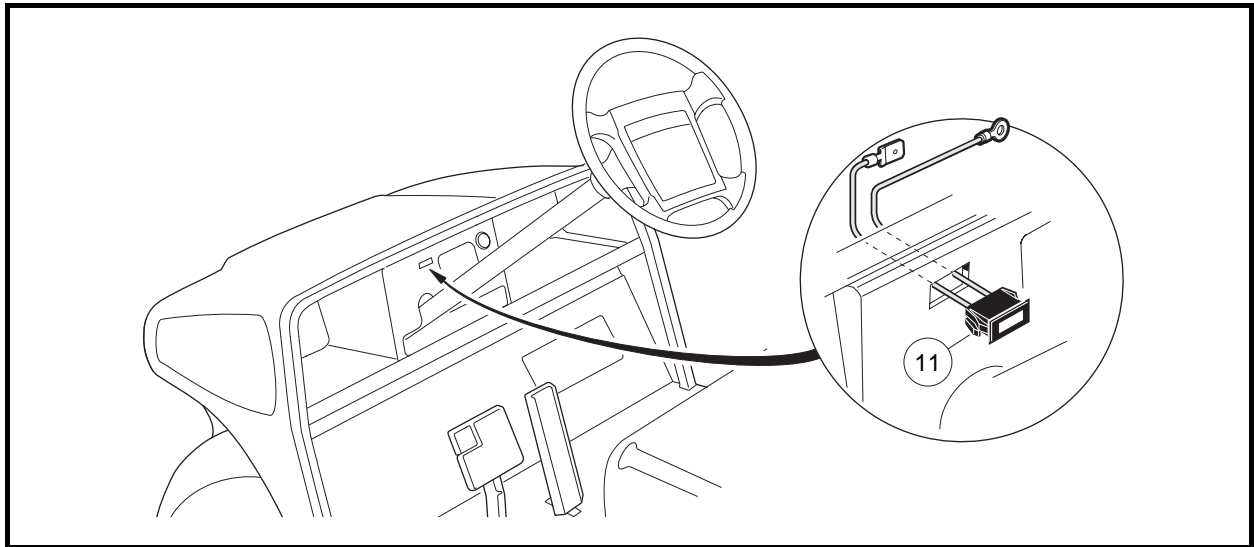
See Test Procedure 18, Section 11, Page 11-40.

### Battery Warning Light Removal

1. Disconnect the battery cables as instructed. See **WARNING "To avoid unintentionally starting..."** in **General Warning, Section 10, Page 10-1**.
2. Remove center dash. See **step 2 of Key Switch Removal on page 13-1**.
3. Disconnect the brown wire at the quick disconnect terminal and remove the orange/white wire from the key switch.
4. Press the two retaining tabs (11) and remove the light from the center dash (**Figure 13-10, Page 13-14**).

### Battery Warning Light Installation

1. Install in reverse order of removal.
2. Place the Tow/Run switch in the TOW position and connect the battery cables, positive (+) cable first. Tighten battery terminals to 110 in-lb (12.4 N·m) and coat terminals with Battery Terminal Protector Spray (CCI P/N 1014305) to minimize corrosion.

**Battery Warning Light, Continued:****Figure 13-10 Battery Warning Light**

## SECTION 14 – BATTERIES

---

### **⚠ DANGER**

- See General Warning, Section 10, Page 10-1.

### **⚠ WARNING**

- See General Warning, Section 10, Page 10-1.

## GENERAL INFORMATION

---

The batteries supplied with an electric Club Car vehicle are different from those supplied with an automobile. The outward appearance of these two batteries is similar, but the operating characteristics are very different. The Club Car electric vehicle battery is a deep-cycle battery, and the automotive battery is a “starting, lighting and ignition” (SLI) battery. They should never be substituted for one another.

An automotive battery has to deliver high-cranking currents of 300-400 amperes at a sufficient voltage for several seconds and maintain an accessory load of 10-25 amperes in stop-and-go driving. The energy removed from an automotive battery is immediately replaced by the alternator or generator. As a result, the automotive battery operates at 90 to 100% of full charge at all times.

The batteries supplied with an electric vehicle must supply 100% of the energy required to operate the vehicle. These batteries therefore, receive a deep discharge down to 30% to 40% of their full charge capacity. Then they must be recharged, hence the name “deep cycle.” The average amperage draw is considered to be 56 amps on a 48 volt vehicle, although it varies greatly depending on the vehicle and how it is operated. Deep-cycle batteries are specifically designed to handle this type of service.

The rechargeable lead-acid battery turns chemical energy into electrical energy and vice versa. The main active elements within a battery are the positive plates, the negative plates and the electrolyte (sulfuric acid). Another very important element (but inactive) is the separator. The separator does exactly what its name implies – it separates the material of the positive and negative plates and prevents them from touching each other, which would create electrical short circuits. The separator is porous enough to allow charged ions to pass between the positive and negative plates, but not allow the two materials to contact each other.

Whenever two unlike metals are immersed in an acid solution, an electric current is generated. In a deep-cycle battery, the negative plates contain lead (Pb) and the positive plates contain lead dioxide (PbO<sub>2</sub>). These plates are immersed in a sulfuric acid solution (H<sub>2</sub>SO<sub>4</sub>) (**Figure 14-1, Page 14-2**).

During discharge, the chemical reaction inside the battery causes the sulfate (SO<sub>4</sub>) to break away from the H<sub>2</sub> (**Figure 14-2, Page 14-2**).

The sulfate (SO<sub>4</sub>) combines with the lead (Pb) on both plates, forming lead sulfate (PbSO<sub>4</sub>). Oxygen (O<sub>2</sub>) from the positive plates combines with hydrogen (H) from the electrolyte to form water (H<sub>2</sub>O) (**Figure 14-3, Page 14-2**).

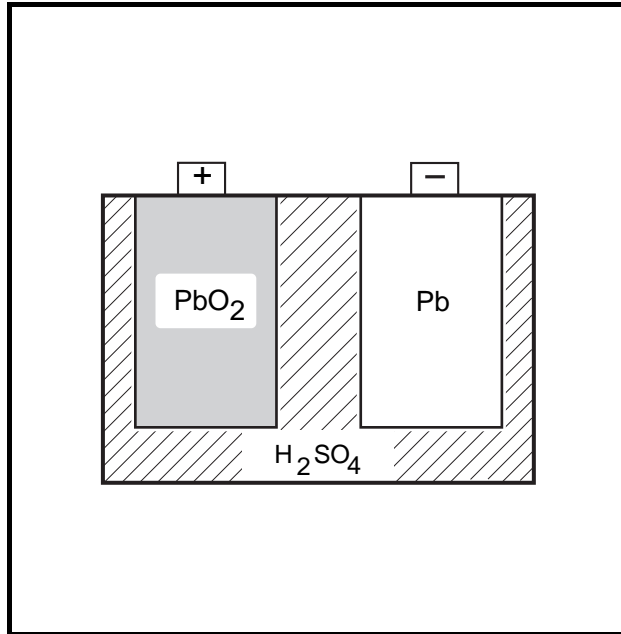


Figure 14-1 Charged Battery

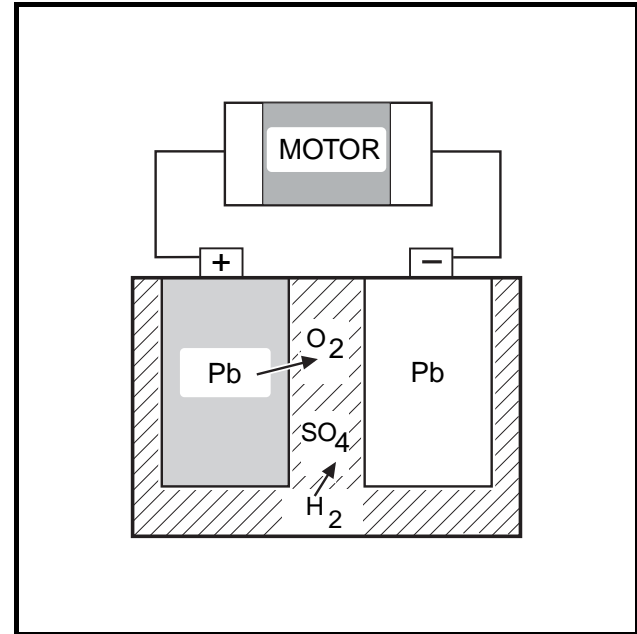


Figure 14-2 Discharging Battery

The result is two similar metals, lead sulfate ( $\text{PbSO}_4$ ) immersed in water ( $\text{H}_2\text{O}$ ). This will not generate electricity because the battery is completely discharged.

When a discharged battery is connected to a charger, the process is reversed. The sulfate ( $\text{SO}_4$ ) is forced from the plates back into the electrolyte to make sulfuric acid ( $\text{H}_2\text{SO}_4$ ). The oxygen returns to the positive plate to make lead dioxide ( $\text{PbO}_2$ ) (**Figure 14-4, Page 14-2**).

The result is a charged battery that is again capable of generating electricity (**Figure 14-1, Page 14-2**).

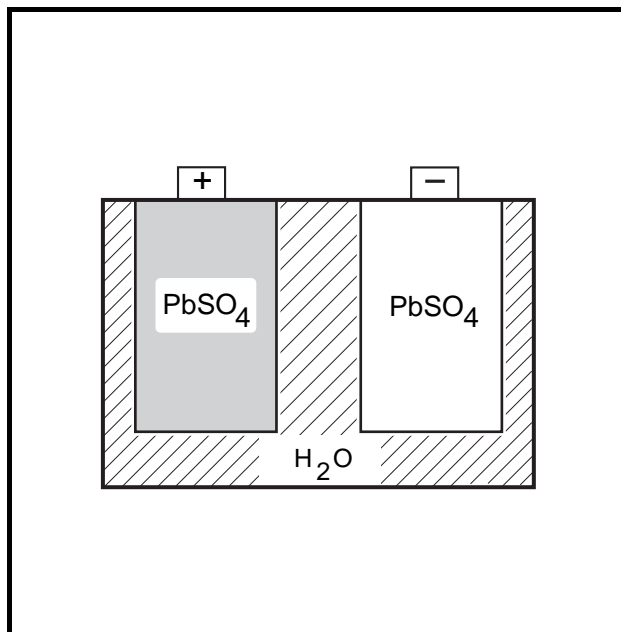


Figure 14-3 Discharged Battery

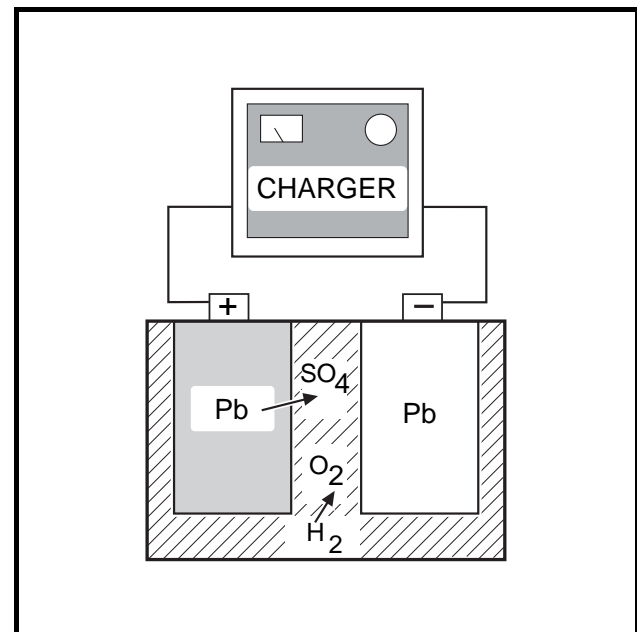


Figure 14-4 Charging Battery

## COMMON MISCONCEPTIONS ABOUT BATTERIES

The chart below describes some of the more common misconceptions that are associated with deep-cycle vehicle batteries and battery care.

PROBLEM	MISCONCEPTION	REALITY
Deep-discharge	"This vehicle is running slowly, but we can run it until it stops."	Avoid deep discharge of batteries whenever possible. <b>See Deep-Discharge on page 14-7.</b>
Early excessive discharging	"These are new batteries. They can run all day."	New batteries do not reach their full capacity until they have been used and recharged 20 to 50 times. <b>See Early Excessive Discharging on page 14-7.</b>
Mineral content	"Tap water will do for our batteries."	Your tap water might be OK, but have it checked first. <b>See Mineral Content on page 14-6.</b>
Self-discharge	"Dirt and corrosion on the battery won't hurt anything."	Dirt and corrosion might provide a path for current to flow and allow the batteries to self-discharge. <b>See Self-Discharge on page 14-5.</b>
Over watering	"Batteries can be filled to the level indicator at night, so it won't have to be done in the morning."	Under most circumstances, water should be added after charging. <b>See Electrolyte Level on page 14-5.</b>
Under watering	"Checking the water takes too much time; it can be checked once a month."	Insufficient watering can ruin batteries. Water level should be checked weekly. <b>See Electrolyte Level on page 14-5.</b>
Vibration damage	"You should tighten battery hold-downs as tight as you can."	Battery hold-downs should be tightened to specification. Hold-downs that are too tight or too loose can cause battery damage. <b>See Vibration Damage on page 14-6.</b>

## BATTERY REPLACEMENT

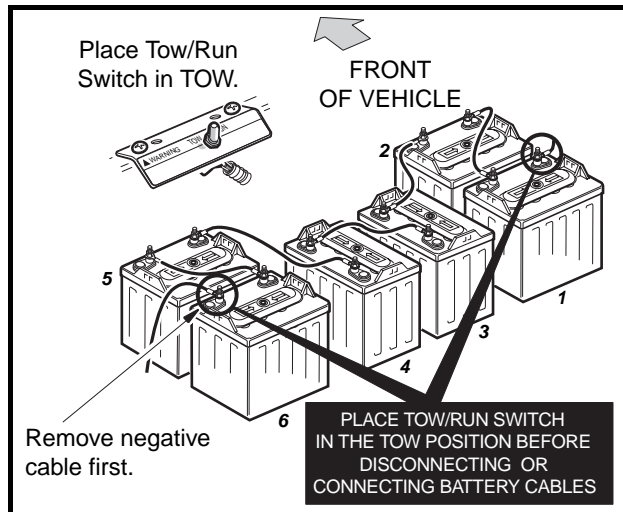
See General Warning, Section 10, Page 10-1.

### **⚠ WARNING**

- To prevent electrolyte leakage from the battery vents, batteries must be kept in an upright position. Tipping a battery beyond a 45° angle in any direction can allow a small amount of electrolyte to leak out the vent hole. Do not exceed this 45° angle when lifting, carrying, or installing batteries. Battery acid can cause severe personal injury to skin or eyes, and can damage clothing.
1. Before removing batteries, note the orientation of the batteries and the connecting wires. Disconnect the battery cables as instructed. **See WARNING "To avoid unintentionally starting..." in General Warning, Section 10, Page 10-1.** Remove remaining wires and batteries. **See Wiring Diagram, Section 11, Page 11-10.**
  2. Visually inspect the new batteries for any damage that may have occurred in transit.

**Battery Replacement, Continued:**

3. If the battery cables are to be reused, inspect them for broken or frayed wires, damaged terminals, or worn insulation. Remove any corrosion on the connectors. A solution of baking soda and water (1 cup (237 mL) baking soda per 1 gallon (3.8 L) of water) does an excellent job of neutralizing and removing the corrosion. Be careful not to allow the baking soda solution to enter the battery.



**Figure 14-5 IQ System Battery Configuration**

4. Check and clean the battery rack and hold-downs. The nuts and bolts on the hold-downs may corrode. It is therefore advised they be cleaned periodically and replaced as necessary.
5. Install batteries in the proper orientation (**Figure 14-5, Page 14-4**). Install battery hold-downs. The hold-downs should be tight enough so batteries do not move while vehicle is in motion, but not so tight as to crack or buckle battery case. Tighten to 40 in-lb (4.5 N·m), alternating between hold-down bolts.
6. Install wires in proper sequence (**Figure 14-5, Page 14-4**). Install black wire to negative post of battery no. 6 last. Make sure all connections are tight. Tighten to 110 in-lb (12.4 N·m). Coat all terminals with Battery Terminal Protector Spray (CCI P/N 1014305) to minimize future corrosion.
7. Give the batteries a full charge prior to operation. This ensures all the batteries are fully charged and the cells are equalized prior to use.

## BATTERY CARE

See General Warning, Section 10, Page 10-1.

## PREVENTIVE MAINTENANCE

To keep batteries in sound operating condition, follow these steps on a regular basis.

1. Any corrosion build-up on or around batteries should be removed immediately. Terminal connections should be clean and tight. Any frayed or worn wires should be replaced. After all cables have been connected, coat all terminals with Battery Terminal Protector Spray (CCI P/N 1014305) to help prevent future corrosion.

2. Batteries should be clean and free of corrosion. Wash tops and terminals of batteries with a solution of baking soda and water (1 cup (237 mL) baking soda per 1 gallon (3.8 L) of water). Rinse solution off batteries. Do not allow this solution to enter the batteries. Be sure terminals are tight. Let the terminals dry and then coat them with Battery Terminal Protector Spray (CCI P/N 1014305). **See Self-Discharge on page 14-5.**
3. Maintain proper electrolyte level. **See Electrolyte Level on page 14-5.**
4. Batteries should be properly charged every day they are used. Check the batteries periodically to see that they are in a full state of charge. **See Battery Charging on page 14-6.**
5. Keep hold-downs tight. **See Vibration Damage on page 14-6.**

## SELF-DISCHARGE

Contaminants on dirty batteries can provide a path for a small current draw that can slowly discharge batteries, thus wasting valuable energy. To prevent self-discharge, batteries should always be kept clean.

Hot weather also has an effect on a battery's self-discharge rate. The higher the temperature, the quicker a set of batteries will discharge. In hotter climates, batteries should be checked more often. When storing batteries, keep in a cool place. **See Battery Storage on page 14-14.**

## ELECTROLYTE LEVEL

### **⚠ CAUTION**

- Do not allow battery acid from battery caps or hydrometer to drip onto the front or rear body of the vehicle. Battery acid will cause permanent damage. Wash immediately.

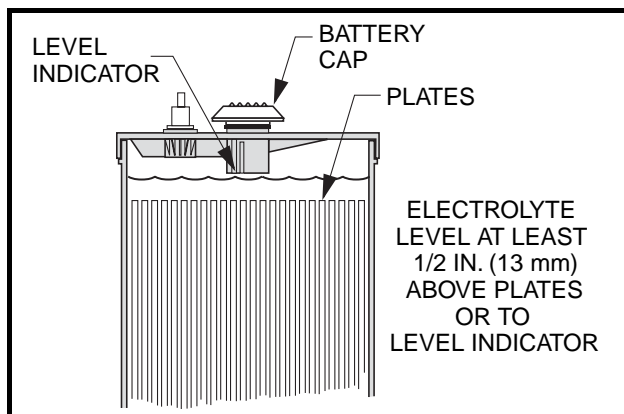


Figure 14-6 Battery Electrolyte Level

Add water only after charging unless the electrolyte is below the level of the plates. If the electrolyte level is below the level of the plates, add just enough water to cover the plates and then charge the batteries. After charging, fill with water to the level indicator. Filling a battery to the level indicator before charging will result in overfilling because the electrolyte level will rise during charging and some of the electrolyte may bubble out of the cap. This reduces the battery's capacity and corrodes the metal parts around it.

**Electrolyte Level, Continued:**

The electrolyte level should be checked weekly to be sure electrolyte is at its proper level (**Figure 14-6, Page 14-5**). Never allow the electrolyte level to fall below the tops of the plates because this will cause the exposed part of the plate to become permanently inactive. For best results, use a battery watering gun to add water to batteries. Check the electrolyte level more frequently in hot weather or when batteries are old.

**MINERAL CONTENT**

For the longest battery life, use distilled water in batteries. However, if tap water is to be used, be sure the mineral contents are below these levels:

IMPURITY	ALLOWABLE CONTENT (PARTS PER MILLION)
Suspended matter	Trace
Total solids	100.0
Calcium and Magnesium Oxides	40.0
Iron	5.0
Ammonia	8.0
Organic matter	50.0
Nitrates	10.0
Nitrites	5.0
Chloride	5.0

**VIBRATION DAMAGE**

The battery hold-downs should always be tight enough to keep the battery from bouncing. Battery life may be severely shortened if the battery hold-downs are too loose. Battery hold-downs should be tightened to 40 in-lb (4.5 N-m). Excessive vibration causes the plates to shed prematurely and shortens the life of the battery. It may also cause acid to leak out of the vent caps and corrosion to build up on surrounding metal parts. The acid which is lost reduces the capacity of the battery and cannot be replaced. Battery hold-downs should NOT be so tight as to crack or buckle the battery case. This may cause leaks which would dry out a cell or cause internal short circuits. **See Battery Replacement on page 14-3.**

**BATTERY CHARGING****See General Warning, Section 10, Page 10-1.**

The charger supplied with the Club Car electric vehicle resolves the most common problems associated with battery charging. Undercharging and overcharging are prevented provided the charger is allowed to shut off by itself. Also, all cells are automatically given an equalization charge at low current, which prolongs battery life. Batteries should never be left in a discharged state, as this too affects the internal components and can reduce the capacity of the battery. The batteries should be charged every day they are used. However, the batteries should not be charged if they have not been used.



## CHARGER SHUTS OFF AFTER 16 HOURS

This may be due to 1) new batteries, 2) hard use, or 3) cold temperatures. A catch-up charge may be necessary when these conditions are present. On those days when all or some of the vehicles do not get used, check the batteries for state of charge. Any battery with a specific gravity lower than 1.250 will need a catch-up charge. If the problem continues after a catch-up charge has been performed, check the battery charger. **See Section 15 – Battery Charger.**

## DEEP-DISCHARGE

Never discharge batteries to the point the vehicle will no longer operate. This will considerably shorten the cycle life of the batteries, and may permanently damage the batteries. It is possible the batteries will not accept a charge if they are completely discharged. The deeper the discharge, the harder it is on the batteries. For this reason, it is recommended that Club Car electric vehicle batteries be charged after each use (provided the charge cycle will not be interrupted and the charger will be allowed to shut off automatically). Placing the batteries on charge after each use reduces the depth of discharge and prolongs battery life.

## EARLY EXCESSIVE DISCHARGING

When vehicle batteries are new, they do not reach their full capacity until they have been used and recharged 20 to 50 times. If they are excessively discharged early in their life, their effective service life will be shortened. It is advisable to limit the use of any vehicle with new batteries for at least the first four weeks and then gradually increase their range.

## INCOMING AC SERVICE

Make sure the incoming AC line service is sufficient. If circuit breakers are tripping, fuses blow during the night or the charger does not give the required starting rate when sound batteries are put on charge, an AC line problem exists. The electrical service to the vehicle storage facility should be sufficient to deliver adequate voltage and current to each charger with all the chargers turned on. If not, consult your local power company or electrical contractor. **See Section 15 – Battery Charger.**

## FLEET ROTATION

Rotate vehicle usage. It is very hard on batteries if the last vehicles in at night are the first ones out in the morning. Spread the workload evenly, giving all vehicles the same amount of use. This will keep your fleet in balance and will not overwork certain sets of batteries.

**NOTE:** *When vehicles are being rotated, the Club Car CDM (Communication Display Module) can be a very helpful service tool. Monitoring the value of function 3 with the CDM simplifies vehicle usage scheduling. See Communication Display Module (CDM), Section 11, Page 11-41.*

## NUMBERING VEHICLES AND CHARGERS

Return the vehicles to the same charger each night if possible. If the vehicles are put in a storage facility at random and a vehicle dies while in use and testing shows the batteries are sound, then the problem is most likely with the charger. However, finding the problem charger may prove to be quite time consuming. Numbering the vehicles and the chargers and returning each vehicle to its designated charger each night can significantly reduce the amount of time spent troubleshooting a problem.

# BATTERY TROUBLESHOOTING CHART

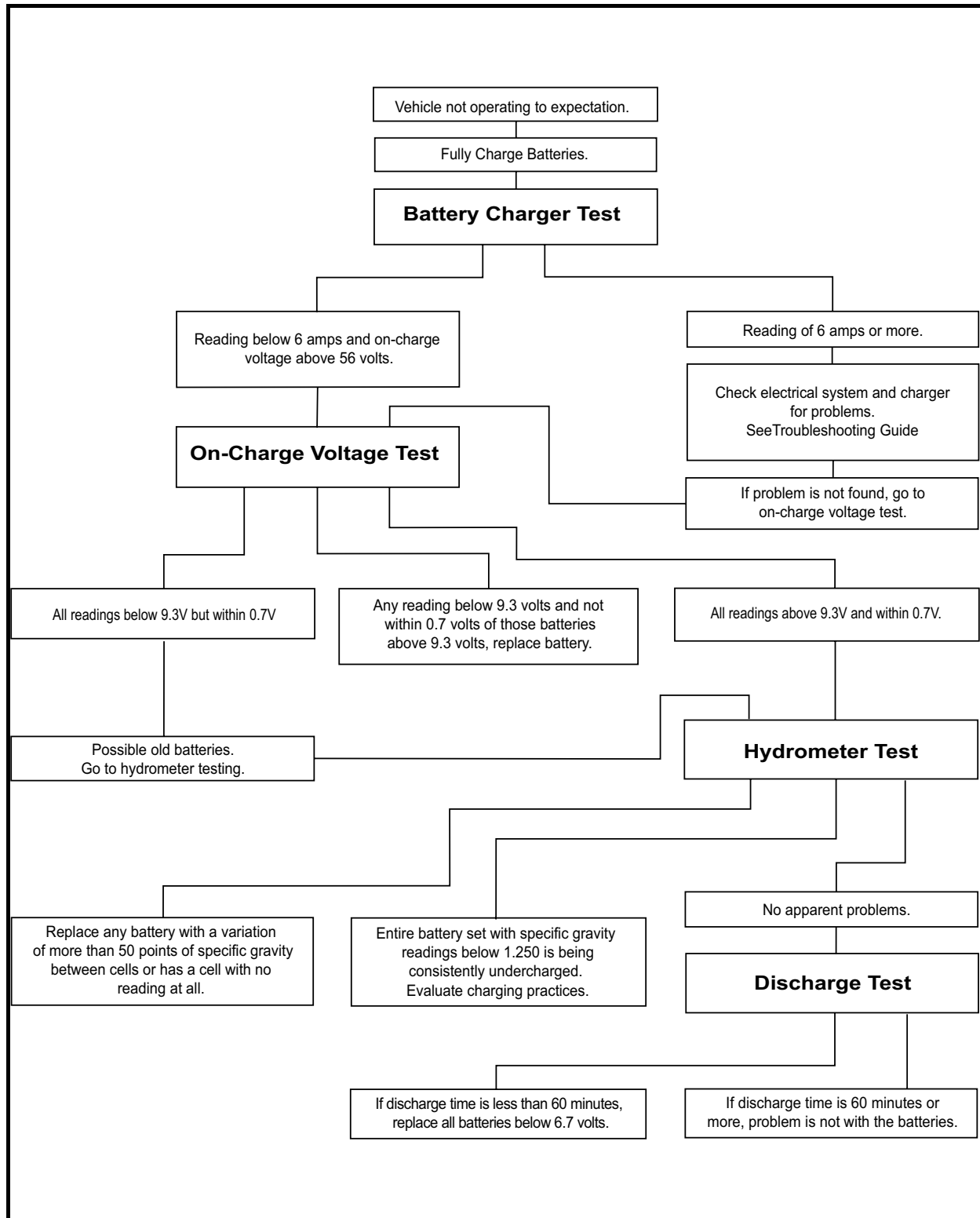


Figure 14-7 Battery Troubleshooting Chart

## BATTERY TESTING

---

### See General Warning, Section 10, Page 10-1.

Four tests have been developed to help diagnose problems with batteries that have not performed as expected. Because each test becomes progressively more detailed and time-consuming, begin with the first test and follow through with the other tests until the problem has been identified as outlined in the Battery Troubleshooting Chart (**Figure 14-7, Page 14-8**).

### BATTERY CHARGER TEST

The easiest way to monitor the condition of a vehicle's batteries is simply to observe the reading on the battery charger ammeter at the end of the charge cycle. After a full charge, disconnect the charger DC plug, wait 20 to 30 seconds and reconnect the charger DC plug. The ammeter needle will jump to 15 amps or more and then taper to below 6 amps within 10 to 20 minutes, indicating sound, fully charged batteries.

Continued poor performance may indicate a problem in the vehicle electrical system, brakes or battery charger. If the problem is not found in the vehicle or charging system, proceed to the on-charge voltage test. Batteries that remain at 8 amps or higher should be tested further using the on-charge voltage test.

### ON-CHARGE VOLTAGE TEST

When the batteries are fully charged, disconnect the charger DC plug. Wait 20 to 30 seconds and reconnect the DC plug to restart the charger. After 5 minutes, use a multimeter to check and record the voltage of the battery set as well as the individual batteries. Set the multimeter to 200 volts DC. Place the red (+) probe on the positive (+) post of battery no. 1 and the black (-) probe on the negative (-) post of battery no. 6 (**Figure 14-5, Page 14-4**). Record reading. Then set multimeter to 20 volts DC and place the red (+) probe on the positive (+) post and the black (-) probe at the negative (-) post of each battery. Record the readings.

The on-charge voltage for the set should be between 56.0 volts and 63.0 volts depending on the age and state of charge of the batteries being tested. If individual batteries read above 9.3 volts and are within 0.7 volts of each other, go to the hydrometer test. If any battery reads below 9.3 volts and not within 0.7 volts of those batteries above 9.3 volts, replace battery. If readings are below 9.3 volts but within 0.7 volts of each other, the batteries are old. Old batteries may have enough capacity left to last several more months. Go to hydrometer test. **See Battery Troubleshooting Chart on page 14-8 and the examples on the following pages.**

### HYDROMETER TEST

A hydrometer measures the specific gravity of the battery's electrolyte. The higher the specific gravity, the higher the state of charge of the batteries. A fully charged battery should read between 1.250 and 1.280 at 80 °F (26.7 °C). Never add acid to batteries to obtain a higher specific gravity.

#### Performing the Hydrometer Test

1. Be sure batteries have sufficient electrolyte to cover plates by approximately 1/2 inch (13 mm) and are fully charged prior to beginning test. If water must be added, recharge the batteries before performing the hydrometer test.
2. Remove the vent cap. Using a battery thermometer (CCI P/N 1011767), record electrolyte temperature of the no. 2 cell.
3. Squeeze the rubber bulb of the hydrometer and insert into the cell. Slowly release the bulb, drawing electrolyte up into the glass tube of the hydrometer.
4. When the float rises off the bottom, adjust the electrolyte level so that the float rides free of the bottom but does not strike the top of the glass tube. Remove the hydrometer from the cell and release the pressure from the bulb.

**Performing the Hydrometer Test, Continued:**

5. Hold the hydrometer vertically, ensuring that the float is not touching the sides of the barrel. Hold the hydrometer at eye level and read the scale at the level of electrolyte (**Figure 14-8, Page 14-10**).
6. Record the reading and return the electrolyte to the cell from which it was taken. Replace vent cap.
7. Repeat steps 2 through 6 on all cells.

**Hydrometer Calibration**

Most hydrometers are calibrated to read correctly at 80 °F (26.7 °C). The readings obtained as described above must be corrected for temperature. For each 10 °F (5.6 °C) above 80 °F (26.7 °C), add .004 to the reading. For each 10 °F (5.6 °C) below 80 °F (26.7 °C), subtract .004 from the reading.

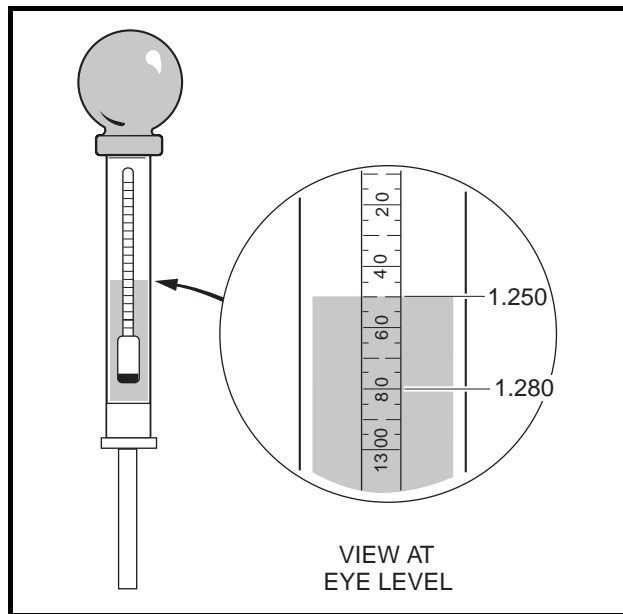


Figure 14-8 Hydrometer

**Interpreting the Results of the Hydrometer Test**

The approximate state of charge can be determined from the following table:

SPECIFIC GRAVITY (TEMPERATURE CORRECTED)	APPROXIMATE STATE OF CHARGE
1.250-1.280	100%
1.220-1.240	75%
1.190-1.210	50%
1.160-1.180	25%

If the difference between the cells is .020 or more, the low cell should be suspected. It may require a catch-up charge or it may be a weak cell. When the variations between cells reach .050 or more, the battery with the low cell should be replaced.

VEHICLE NO.	BATTERY NO.	ELECTROLYTE TEMPERATURE	CORRECTION FACTOR	CORRECTED SPECIFIC GRAVITY				REQUIRED ACTION
				CELL 1	CELL 2	CELL 3	CELL 4	
12	1	20 °F (-6.6 °C)	-.024	1.275 -.024 = 1.251	1.280 -.024 = 1.256	1.280 -.024 = 1.256	1.280 -.024 = 1.256	Sound Battery - Fully Charged
35	6	90 °F (32.2 °C)	+.004	1.155 +.004 = 1.159	1.165 +.004 = 1.169	1.160 +.004 = 1.164	1.165 -.004 = 1.169	Discharged Battery - Recharge
54	3	50 °F (10 °C)	-.012	1.260 -.012 = 1.248	1.200 -.012 = 1.188	1.270 -.012 = 1.258	1.270 -.012 = 1.258	Bad no. 2 Cell
69	5	80 °F (26.7 °C)	.000	1.250 - 0 = 1.250	1.255 - 0 = 1.255	1.230 - 0 = 1.230	1.250 - 0 = 1.250	Weak no. 3 Cell - Catch-up Charge
38	2	100 °F (37.8 °C)	+.008	1.200 +.008 = 1.208	1.180 +.008 = 1.188	1.170 +.008 = 1.178	1.180 +.008 = 1.188	Discharged Battery - Recharge and Recheck
22	4	80 °F (26.7 °C)	.000	1.240 - 0 = 1.240	1.245 - 0 = 1.245	Float does not rise	1.250 - 0 = 1.250	no.3 Cell Dead - Replace Bat- tery

### DISCHARGE TEST

If the previous tests have failed to identify the problem, conduct a discharge test. The discharge test comes closest to simulating actual vehicle operating conditions by continuously drawing current from the batteries until voltage drops to 42.0 volts.

The discharge test is the hardest test on the batteries and the most time-consuming to perform. Use the battery discharge tester (CCI P/N 101831901).

### Performing the Discharge Test

1. Be sure the batteries are fully charged and that the electrolyte level is correct in all cells.
2. Connect the tester leads to the positive (+) post of battery no.1 and negative (-) post of battery no. 6 (Figure 14-9, Page 14-11).

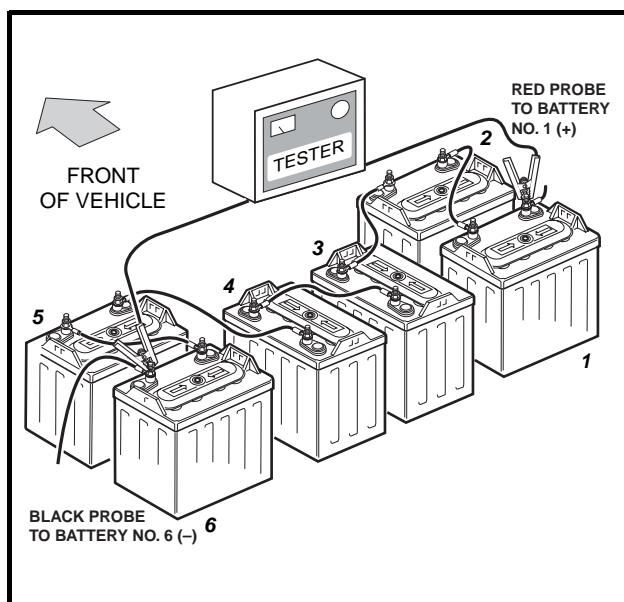


Figure 14-9 Battery Discharge Test

**Performing the Discharge Test, Continued:**

3. Check and record the electrolyte temperature of the battery packs. Check cell no. 2 (second cell from positive post) in each battery.
4. Reset discharge machine and turn the tester ON.
5. When the batteries have been discharging for approximately 60 minutes, set the discharge machine to function 3 and check battery set voltage. Check voltage every 10 minutes throughout the rest of the test. As soon as the battery set voltage reaches .5 volts above the shut-off point (42.0 volts), use a multimeter to measure individual battery voltages. Measure and record the voltage of each battery to the nearest .01 volt.

**NOTE:** The tester will shut off automatically when shut-off voltage is reached.

**Interpreting Discharge Test Results**

1. If discharge time is 60 minutes or higher, the problem is not with the batteries.
2. If discharge times are low (less than 60 minutes), replace batteries below 6.7 volts.

BATTERY VOLTAGES						BATTERY CONDITION
1	2	3	4	5	6	
7.00 V	7.00 V	7.00 V	7.00 V	7.00 V	7.00 V	Excellent
7.07 V	7.07 V	7.22 V	6.50 V	7.07 V	7.07 V	Battery no. 4 is near end of useful life
7.20 V	7.20 V	6.67 V	7.33 V	6.27 V	7.33 V	Battery nos. 3 and 5 are near end of useful life

3. In general, battery sets that discharge in less than 60 minutes at 78 °F (25.6 °C) on the discharge test will typically not hold a charge for an entire work shift. However, discharge time is dependent on the electrolyte temperature. The table shown gives the discharge times, at various temperatures, of a set of batteries that delivers 62 minutes at 80 °F (26.7 °C).

ELECTROLYTE TEMPERATURE	DISCHARGE TIME TO SHUT-OFF POINT	ELECTROLYTE TEMPERATURE	DISCHARGE TIME TO SHUT-OFF POINT
40-49 °F (4-9 °C)	40 Minutes	85-89 °F (29-32 °C)	64 Minutes
50-59 °F (10-15 °C)	45 Minutes	89-99 °F (32-37 °C)	66 Minutes
60-64 °F (16-18 °C)	50 Minutes	100-109 °F (38-43 °C)	68 Minutes
65-69 °F (18-21 °C)	54 Minutes	110-119 °F (43-48 °C)	70 Minutes
70-74 °F (21-23 °C)	57 Minutes	120-129 °F (49-54 °C)	72 Minutes
75-79 °F (24-26 °C)	60 Minutes	130-150 °F (54-66 °C)	74 Minutes
80-84 °F (27-29 °C)	62 Minutes	*****	*****

## BATTERY TROUBLESHOOTING EXAMPLES

The following information represents a few examples of troubleshooting battery problems.

### Example 1

Vehicle no. 68 was suspected of having a bad battery due to its performance. As a result, the battery charger test was performed. After a full charge, the battery charger ammeter read 8.0 amps. Next, the on-charge voltage test was performed and the following results were recorded:

BATTERY NO.	1	2	3	4	5	6
On-Charge Voltage	10.15 V	10.60 V	9.80* V	10.16 V	10.56 V	10.61 V

\*Battery no. 3 appears suspect. Battery nos. 1 and 4 are also suspect. Next, a hydrometer test should be conducted on all batteries.

### Hydrometer test results:

CELL NUMBER	BATTERY NUMBER					
	1	2	3	4	5	6
Cell 1 (Positive Post)	1.200*	1.265	1.300	1.250	1.280	1.260
Cell 2	1.285	1.275	1.290	1.270	1.295	1.265
Cell 3	1.265	1.270	1.275	1.265	1.280	1.275
Cell 4 (Negative Post)	1.275	1.270	1.285	1.265	1.275	1.275

\*After the hydrometer test, it appears that battery no. 1 is the problem. Next, the discharge test was performed.

### Discharge test results:

BATTERY NO.	1	2	3	4	5	6
Discharge Voltage	5.44* V	7.33 V	7.73 V	7.15 V	7.43 V	7.41 V

\*After a discharge test which lasted 45 minutes, battery no. 1 is clearly shown to be the problem. Battery no. 4 should be watched a little more closely but appears to be okay. Battery no. 1 should be replaced with a battery that has about the same age and usage as the other batteries in the set.

### Example 2

Vehicle no. 70 was also suspected of having a bad battery due to its performance. The battery charger test showed 7.0 amps after a full charge. After confirming there were no problems with the electrical system, charger or brakes, the on-charge voltage was recorded as follows:

BATTERY NO.	1	2	3	4	5	6
On-Charge Voltage	10.48 V	9.77* V	10.53 V	10.57 V	10.55 V	10.33 V

\*Battery no. 2 was immediately suspected as the problem. After checking battery no. 2 with a hydrometer, it was discovered that the negative post cell was completely dead. Battery no. 2 should be replaced with a battery that has the same age and usage as the other batteries in the set.

## BATTERY STORAGE

---

### See General Warning, Section 10, Page 10-1.

When storing batteries during the off-season or when maintaining a replacement stock, follow these guidelines:

1. Keep the batteries clean and free of corrosion. **See Battery Care on page 14-4.**
2. Batteries that are in vehicles for winter storage should be left disconnected in the vehicles if the batteries are not going to be connected to a charger.
3. Fully charge the batteries prior to storage.
4. Store in a cool area. The colder the area in which the batteries are stored, the less the batteries will self-discharge. Batteries stored at 0 °F (−17.8 °C) will discharge very little over a four-month period. Batteries stored at 80 °F (26.7 °C) will have to be recharged every few weeks.
5. 48-volt Club Car electric vehicles and compatible battery chargers are designed to be left connected, with AC power to the charger ON, during off-season storage. The storage charge feature will automatically charge the batteries as needed throughout the storage period.

## CHARGING A BATTERY PACK THAT HAS LOW VOLTAGE

---

See the appropriate battery charger maintenance and service manual.



## SECTION 15 – BATTERY CHARGER

---

Refer to the appropriate battery charger maintenance and service manual.



# SECTION 16 – MOTOR

---

## **⚠ DANGER**

- See General Warning, Section 10, Page 10-1.

## **⚠ WARNING**

- See General Warning, Section 10, Page 10-1.

## GENERAL INFORMATION

---

The IQ System vehicle is equipped with a 48-volt DC, shunt-wound, reversible traction motor. The shunt-wound motor is designed for use on the IQ System vehicle only. Club Car recommends that motors requiring major repair be sent to a qualified motor repair shop; however, there are many relatively simple tasks that can be performed by a technician with general knowledge and experience in electric motor repair.

## EXTERNAL MOTOR TESTING

---

Using a multimeter or continuity tester, the following tests can be performed without disassembling the motor.

***NOTE:** Tag the motor wires for identification before disconnecting.*

## TEST PROCEDURE 1 – INTERNAL SHORT CIRCUITS

See General Warning, Section 10, Page 10-1.

1. Disconnect the battery cables as instructed. See **WARNING "To avoid unintentionally starting..." in General Warning, Section 10, Page 10-1.**
2. Using two wrenches to prevent posts from turning, disconnect wires from terminals on motor.
3. Using a multimeter set to 200 ohms, place black (–) probe on motor housing. Scratch through paint to ensure a good connection. Place red (+) probe on A1, A2, F1, and F2 terminals respectively (**Figure 16-1, Page 16-2**). Multimeter should indicate no continuity. If readings are incorrect, motor will need to be removed from the vehicle and repaired by a qualified technician. See **Motor Removal on page 16-3.**
  - 3.1. An incorrect reading from the A1 or A2 terminal indicates three possible problems: a grounded A1 or A2 terminal, a grounded wire in the brush area, or a grounded armature/commutator. An incorrect reading for the F1 or F2 terminal indicates a possible grounded F1 or F2 terminal or field coil.

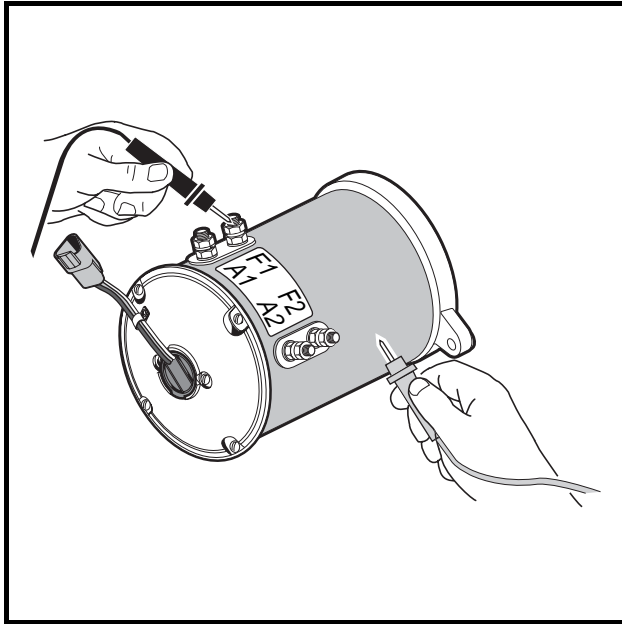
**External Motor Testing, Continued:**

Figure 16-1 Motor Short Circuit Test

**TEST PROCEDURE 2 – ARMATURE CIRCUIT OPEN****See General Warning, Section 10, Page 10-1.**

1. Disconnect the battery cables as instructed. **See WARNING "To avoid unintentionally starting..." in General Warning, Section 10, Page 10-1.**
2. Using two wrenches to prevent the posts from turning, disconnect wires from the A1 and A2 terminals on the motor. Using a multimeter set to 200 ohms, place the red (+) probe on the A1 terminal and black (-) probe on the A2 terminal. The multimeter should indicate continuity. If the reading is incorrect, a possible open or poor contact in a brush assembly and/or open armature windings may be the cause. The motor will need to be removed from the vehicle and repaired by a qualified technician. **See Motor Removal on page 16-3.**

**TEST PROCEDURE 3 – FIELD CIRCUIT OPEN****See General Warning, Section 10, Page 10-1.**

1. Disconnect the battery cables as instructed. **See WARNING "To avoid unintentionally starting..." in General Warning, Section 10, Page 10-1.**
2. Using two wrenches to prevent post from turning, disconnect wires from the motor F1 and F2 terminals. Using a multimeter set to 200 ohms, place the red (+) probe on the F1 terminal and the black (-) probe on the F2 terminal. The multimeter should indicate continuity. If the reading is incorrect, a possible open field coil or bad connections at the terminals may be the cause. The motor will need to be removed from the vehicle and repaired by a qualified technician. **See Motor Removal on page 16-3.**

## MOTOR

See General Warning, Section 10, Page 10-1.

### Motor Removal

1. Disconnect the battery cables as instructed. See **WARNING "To avoid unintentionally starting..."** in **General Warning, Section 10, Page 10-1.**
2. Using two wrenches to prevent posts from turning, disconnect wires from terminals on motor. Label the wires to ensure proper reconnection.
3. Slightly loosen all the lug nuts on both rear wheels.
4. Place floor jack under transaxle and raise rear of vehicle (**Figure 16-2, Page 16-3**) then place jack stands under frame crossmember between the spring mount and the side stringer, just forward of each rear wheel. Lower the vehicle to let the jack stands support the vehicle (**Figure 16-3, Page 16-3**). See following **WARNING**.

### **⚠** WARNING

- **Lift only one end of the vehicle at a time. Use a suitable lifting device (chain hoist or hydraulic floor jack) with 1000 lb. (454 kg) minimum lifting capacity. Do not use lifting device to hold vehicle in raised position. Use approved jack stands of proper weight capacity to support the vehicle and chock the wheels that remain on the floor. When not performing a test or service procedure that requires movement of the wheels, lock the brakes.**

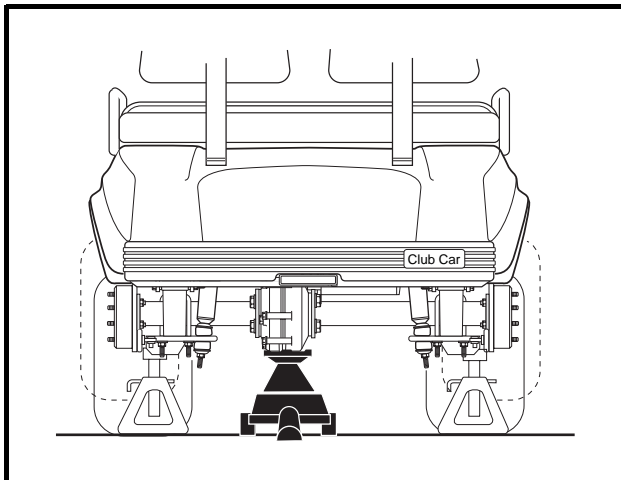


Figure 16-2 Lift Vehicle with Floor Jack

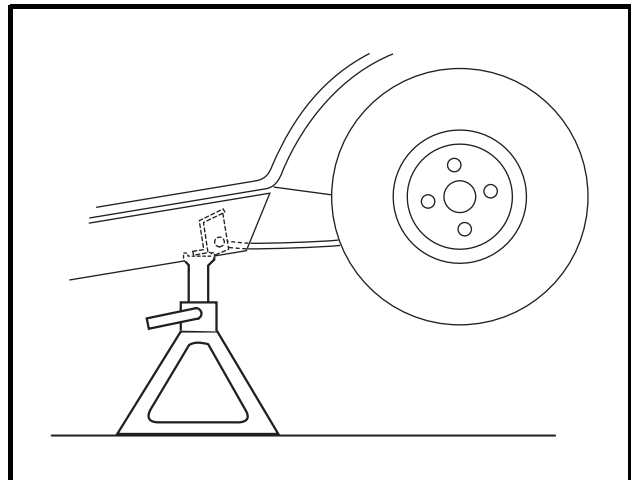
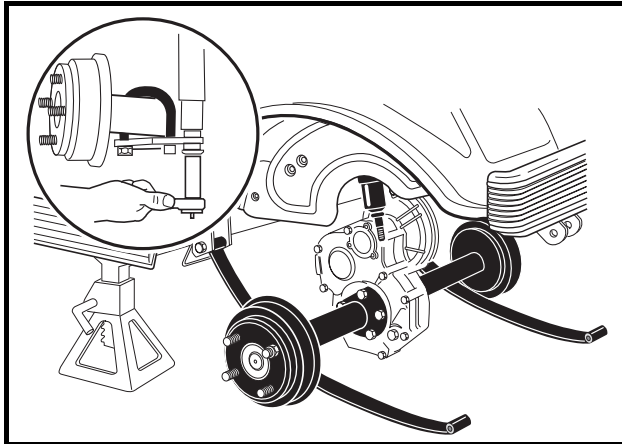


Figure 16-3 Vehicle Supported on Jack Stands

5. Remove both rear wheels.
6. Remove the nut, cup washer, and bushing from the bottom side of the shock absorber. Compress the shock absorber (pushing upwards) to move it out of the way.
7. Remove the nuts and bolts mounting the rear leaf springs to the shackles.

**Motor Removal, Continued:**

- To gain easier access to the motor, lower the transaxle as low as it will go. If more room is needed, remove the jack from beneath the transaxle and allow the springs to rest on the floor (**Figure 16-4, Page 16-4**).



**Figure 16-4 Lower Axle**

- Remove the four bolts that mount the motor to the transaxle (**Figure 16-19, Page 16-15**). See following **CAUTION**.

**⚠ CAUTION**

- Do not position fingers under motor when sliding motor off of the input shaft in step 9. Fingers may get pinched when motor disengages.

- Carefully slide the motor away from the transaxle until the motor spline disengages the input shaft and remove the motor from the vehicle.

**Motor Disassembly**

- Before beginning disassembly, place match marks on the motor end shield and stator shell, then place the motor in a vice with wooden blocks as shown (**Figure 16-5, Page 16-5**).
- Remove the four bolts (8) securing the end shield (10) to the stator shell (2).
- Remove the two screws (9) attaching the end shield to the bearing retainer.
- Slide the armature (17) out of the opposite end of the stator shell (2).
- Remove two screws (11) attaching brush rigging (12) to the stator shell (2) (**Figure 16-10, Page 16-8**).
- Mark the brush terminal posts (A1 and A2) (13) to identify their positions in the stator shell, then remove the nuts (6) and flat washers (5) (**Figure 16-10, Page 16-8**). From the outside, push the posts through the stator shell wall into the interior of the stator shell.
- Carefully remove the brush rigging and the terminal posts from the stator shell.
- To remove brush springs (14) from the rigging, lift the spring extensions out and over the brush mounts and then slide the springs off their mounting tabs (**Figure 16-6, Page 16-5**).

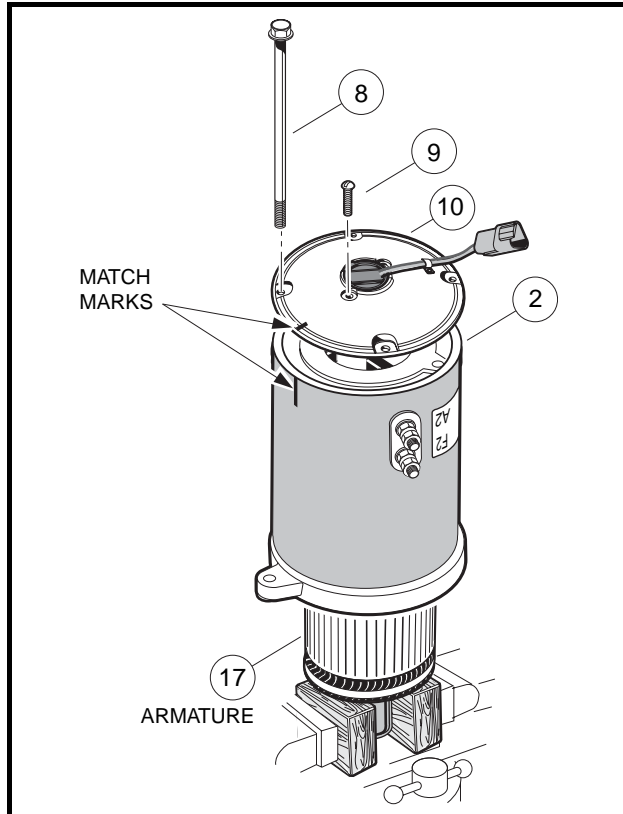


Figure 16-5 Motor Disassembly

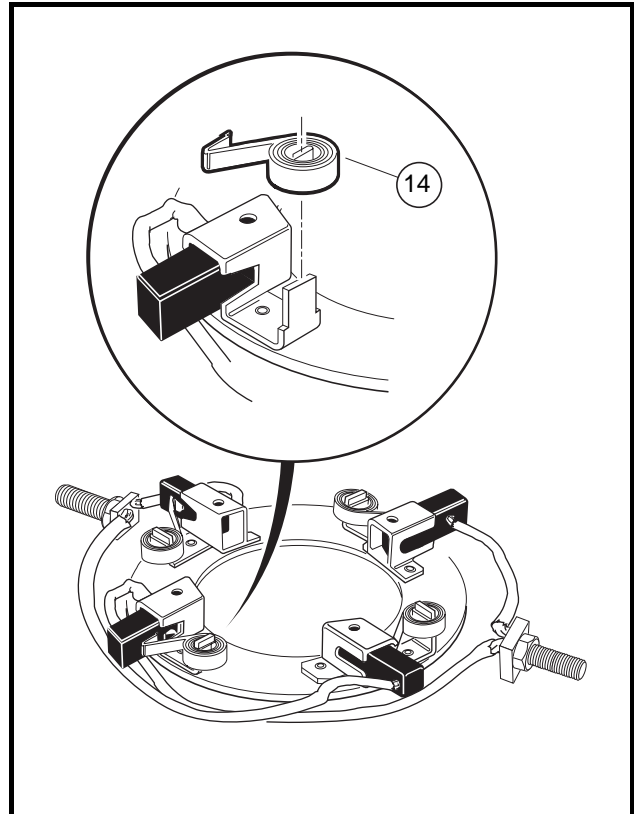


Figure 16-6 Brush Spring Removal

## MOTOR COMPONENT TESTING AND INSPECTION

See General Warning, Section 10, Page 10-1.

### ARMATURE

#### Visual Inspection

Disassemble the motor and carefully inspect the armature for the following characteristics:

- Burned, charred or cracked insulation
- Improperly cured varnish
- Thrown solder
- Flared armature windings
- Damaged armature core laminations
- Worn, burned or glazed commutators
- Dirty or oily commutators
- Raised commutator bars
- Worn armature bearing or shaft

### Visual Inspection, Continued:

A dirty or oily commutator should be cleaned and wiped dry. Abnormalities identified during the inspection can help determine original cause of failure. Slight roughness of the commutator can be polished smooth with 400 grit or finer sandpaper. **See following CAUTION and NOTE.**

#### **⚠ CAUTION**

- Do not use emery cloth to polish the commutator. Particles of emery are conductive and may short-circuit the commutator bars. Do not use oil or lubricants on the commutator or brushes.

**NOTE:** Oil on the commutator may indicate a faulty transaxle input shaft oil seal.

### Armature Ground Test

#### **⚠ CAUTION**

- Do not submerge the armature in solvent.

**NOTE:** Before testing the armature, wipe it clean with a clean cloth. Remove any carbon dust and metal particles from between the commutator bars.

1. With a multimeter set to 200 ohms, place one probe on the commutator and the other on the armature core. The multimeter should indicate no continuity (**Figure 16-7, Page 16-6**). If the reading is incorrect, replace the armature.

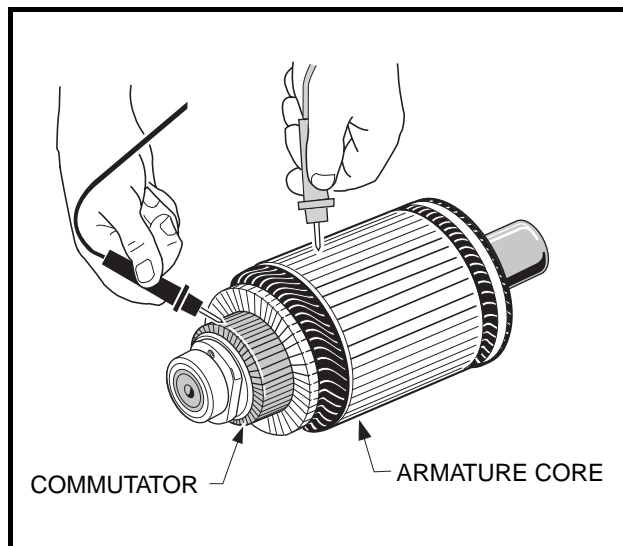


Figure 16-7 Armature Test

### FIELD WINDINGS INSPECTION

Burned or scorched insulation on the field windings indicates the motor has overheated due to overloads or grounded or shorted coil windings. If the insulation on the field windings is scorched, replace the motor or the stator shell assembly.



## MOTOR COMPONENTS

1. Inspect the insulators (4 and 7) for cracks or other damage (**Figure 16-10, Page 16-8**).
2. Inspect the brushes (13) for damage or excessive wear. Replace brushes if required. **See following NOTE.**
3. Inspect the brush springs (14) (**Figure 16-10, Page 16-8**). Replace springs that are discolored from heat (light gold or blue tinted). Replace springs which apply a force of less than 16 oz. (**Figure 16-8, Page 16-7**).

### **⚠ CAUTION**

- **When checking brush spring tension, do not over-extend the spring. Using excessive force will damage the spring.**

**NOTE:** When installing new brushes, remove and replace brushes one at a time. This method ensures the terminals and brushes will be properly positioned in the rigging. Refer to Motor Assembly for brush installation. **See Motor Assembly on page 16-10.**

*When replacing brushes, replace all four brushes. Never replace only two.*

*Install the brushes in the same rigging 180° apart from each other.*

## BEARING INSPECTION

1. Using a clean cloth, wipe the carbon dust off of the bearing. Inspect the bearing by spinning it by hand and checking for both axial (A) and radial (B) play (**Figure 16-9, Page 16-7**).
2. Replace the bearing if it is noisy, does not spin smoothly, or has excessive play. Check the bearing and replace if rusted, worn, cracked, or if there is an abnormal color change in the metal of the bearing. Do not remove the bearing from the armature shaft unless it is to be replaced.

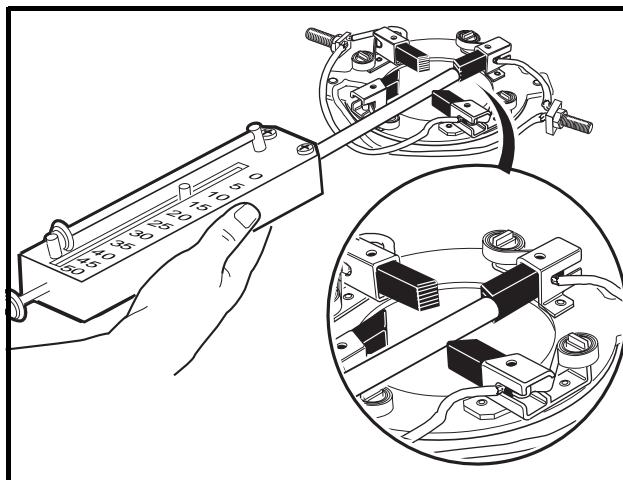


Figure 16-8 Brush Spring Tension Test

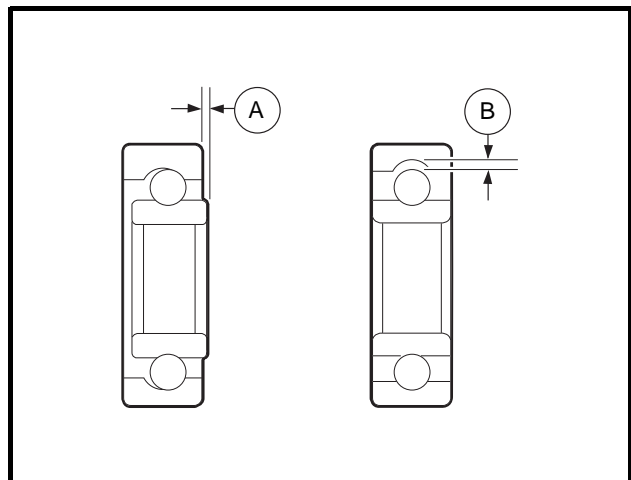


Figure 16-9 Inspect Bearing

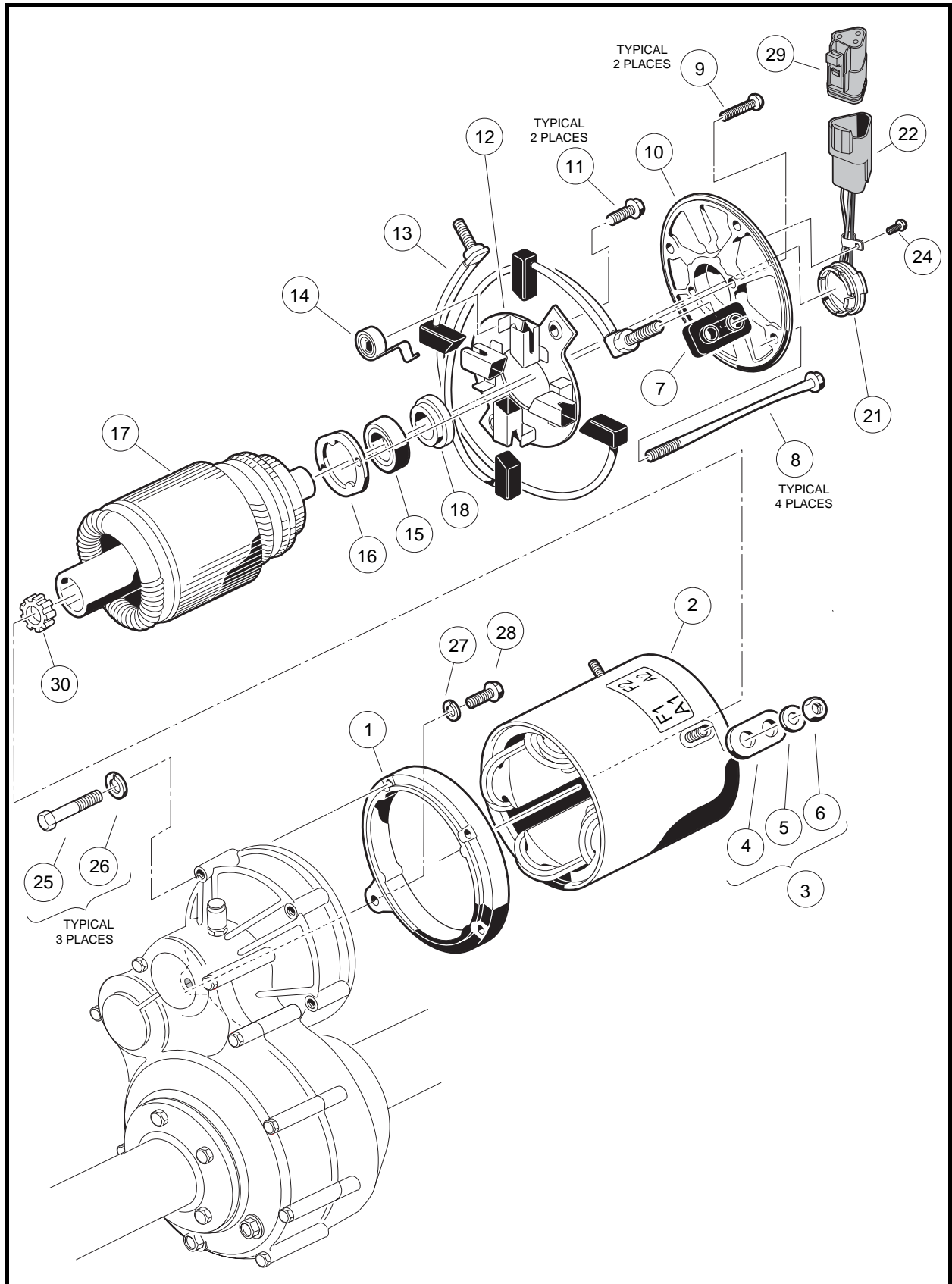


Figure 16-10 Motor

## BEARING REMOVAL

1. Place the wedge attachment tool (CCI P/N 1012812) between the bearing (15) and the armature (17) (**Figure 16-10, Page 16-8**). Make sure the wedge attachment tool is supporting the inner race of the bearing. If a press is not available, secure a bearing puller (CCI P/N 1012811) to the bearing and pull the bearing off of the end of the armature shaft. Support the shaft so it will not drop when the bearing is removed (**Figure 16-11, Page 16-11**). Discard the bearing and speed sensor magnet. **See following NOTE.**

**NOTE:** The speed sensor magnet will be pressed off by the bearing when the bearing is removed.

## BEARING INSTALLATION

1. Press a new bearing (15) onto the armature (**Figure 16-10, Page 16-8**). Use an arbor press that exerts pressure on the inner race only. **See following NOTE.**

**NOTE:** Make sure the bearing retainer (16) is positioned on the armature shaft before the bearing is pressed onto the armature (**Figure 16-10, Page 16-8**).

*An arbor with an outside diameter of less than 5/8 inch (16 mm) should be used to press the bearing onto the armature.*

2. Install the speed sensor magnet. **See Speed Sensor Magnet Installation on page 16-9.**

## SPEED SENSOR MAGNET INSPECTION

Inspect the speed sensor magnet (18) for rust, wear, and cracks (**Figure 16-10, Page 16-8**). Replace the magnet if necessary.

## SPEED SENSOR MAGNET REMOVAL

1. To remove the speed sensor magnet (18), remove the motor bearing (**Figure 16-10, Page 16-8**). **See Bearing Removal on page 16-9.**

## SPEED SENSOR MAGNET INSTALLATION

1. Using a solid bearing driver with a diameter of no less than 1 inch (2.54 cm), press the motor speed sensor magnet (18) onto the shaft until the magnet hub is flush with the armature shaft.

## RECONDITIONING THE MOTOR

---

**See General Warning, Section 10, Page 10-1.**

Motor reconditioning must be performed by a qualified motor repair technician. The use of proper tools and procedures is absolutely essential for successful motor reconditioning.

## Motor Specifications

Any rework must be performed by a qualified technician. Motor service specifications are listed in the following table.

ITEM	SERVICE LIMIT
Commutator diameter (minimum)	2.265 in. (66.675 mm)
Commutator concentric with armature shaft within	0.001 in. (0.0254 mm)
Limit depth of cut when machining commutator	0.005 in. (0.127 mm)
Bar to bar runout should not exceed	0.002 in. (0.00508 mm)
If undercut of segment insulator is less than .016 inch (0.406 mm), it should be undercut to	0.031 in. (0.8 mm)
Machined face of commutator	8-16 microinches (203.2-406.4 nm)
Field coil resistance (IQ System, 3.20 hp)	1.61 ohms

## MOTOR ASSEMBLY

See General Warning, Section 10, Page 10-1.

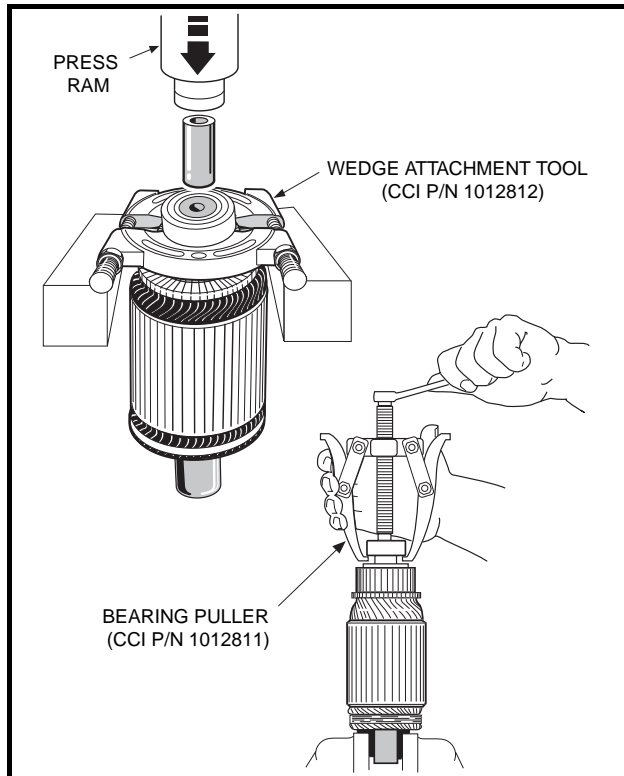
1. If the bearing has been removed, replace the bearing. See **Bearing Installation on page 16-9.**
2. Install the brushes. See **following NOTE.**

**NOTE:** When installing new brushes, remove and replace brushes one at a time. This method ensures the terminals and brushes will be properly positioned in the rigging. Refer to Motor Assembly for brush installation. See **Motor Assembly on page 16-10.**

*When replacing brushes, replace all four brushes. Never replace only two.*

*Install the brushes in the same rigging 180° apart from each other.*

- 2.1. With brush rigging facing down and held slightly above stator shell, insert the two terminal posts through insulators in stator shell wall at the A1 and A2 positions. Insert brush holder screws through the holes in the brush rigging and into the threaded holes in the mounting bracket (**Figure 16-12, Page 16-12**). Tighten the screws to 20 in-lb (2.3 N·m).
- 2.2. One at a time, push brush spring extensions back from brushes and slide the brushes back until they are completely retracted into their mounting slots. Then position the brush springs against the sides of the brushes so that spring pressure will hold them in the retracted position (**Figure 16-6, Page 16-5**).



**Figure 16-11 Bearing Removal**

- 2.3. Slide the armature, bearing end first, into the stator shell. Make sure the brushes are held back while positioning the armature for proper commutator/brush contact. Release the brushes and place the springs outside the brushes so the brushes are being held against the commutator. **See following CAUTION.**

### **⚠ CAUTION**

- If the motor is being assembled with the armature standing on end as the commutator is positioned, make sure the brushes are held back. Do not allow the brushes to support the weight of the stator shell. The brushes can be easily damaged by this weight.

3. Install the end shield onto the stator shell.

- 3.1. Attach the end shield (10) to bearing retainer (16) by aligning the two holes in the bearing retainer with the two mating holes in the end shield and installing the screws (9) (**Figure 16-10, Page 16-8**). Tighten the screws to 17 in-lb (1.9 N·m). **See following NOTE.**

**NOTE:** Use a long screw with the same thread specifications as the mounting screws to maintain hole alignment while starting the first mounting screw (**Figure 16-13, Page 16-12**).

- 3.2. Align the match marks on the end shield and the stator shell, then install the four screws (8) (**Figure 16-10, Page 16-8**). Tighten the screws to 90 in-lb (10 N·m).

**NOTE:** Make sure the motor speed sensor wires located on the end shield are aligned between the terminals on the motor housing.

4. Make sure the armature turns freely. If it does not turn freely, disassemble the motor to find the problem. Make sure the bearing is properly seated in the end shield when assembling the motor.

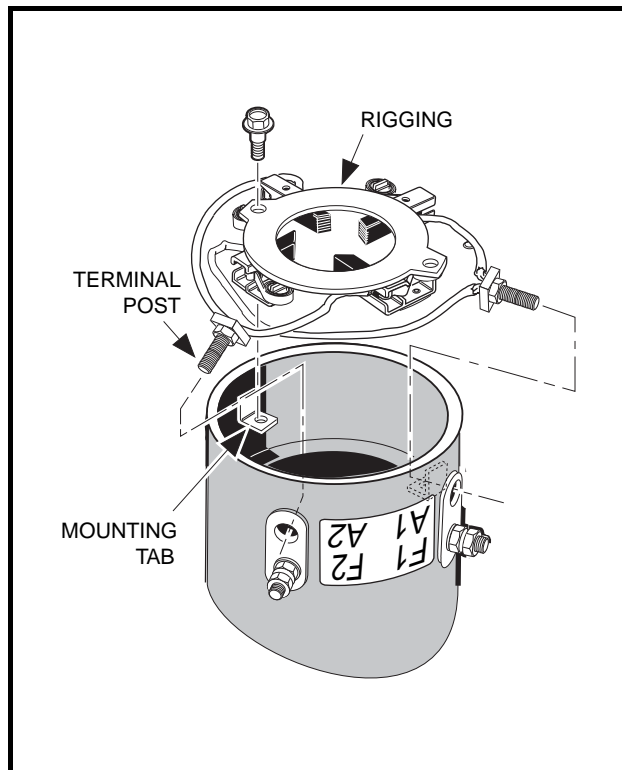
**Motor Assembly, Continued:**

Figure 16-12 Brush Installation

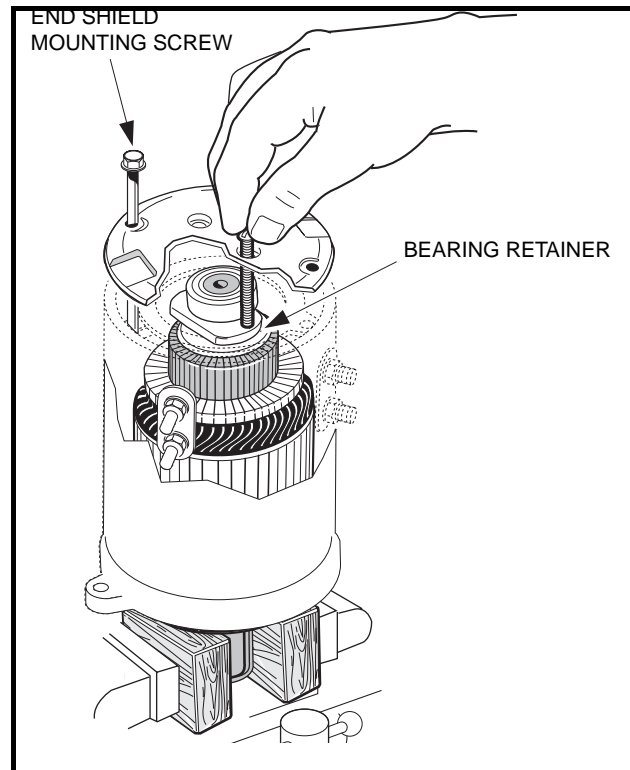


Figure 16-13 End Shield Installation

**MOTOR INSTALLATION****See General Warning, Section 10, Page 10-1.**

1. Clean the transaxle input shaft.
  - 1.1. Spray the input shaft thoroughly with CRC® Brakleen™ or equivalent brake cleaner degreaser.
  - 1.2. Wipe input shaft with a clean cloth.
  - 1.3. Inspect the grooves of the input shaft and remove any remaining debris.
  - 1.4. Repeat steps 1.1 through 1.3 until input shaft is clean.
2. Lubricate the transaxle input shaft.
  - 2.1. Squeeze approximately 1/2 inch (1.3 cm) of moly-teflon lubricant (CCI P/N 102265201) from tube onto a putty knife as shown (**Figure 16-14, Page 16-13**).
  - 2.2. Rotate wheels to rotate input shaft.
  - 2.3. Apply motor coupling grease evenly to the rotating input shaft starting at approximately 1/8 inch (3.1 mm) from the end of the shaft and working back toward the transaxle (away from the end of the shaft) (**Figure 16-15, Page 16-13**).
  - 2.4. The grease should be evenly distributed in the grooves to a width of approximately 3/8 inch (9.5 mm).
  - 2.5. Using a flat screwdriver, clean the grease out of one of the grooves to allow air to escape when the motor is pushed onto the input shaft.

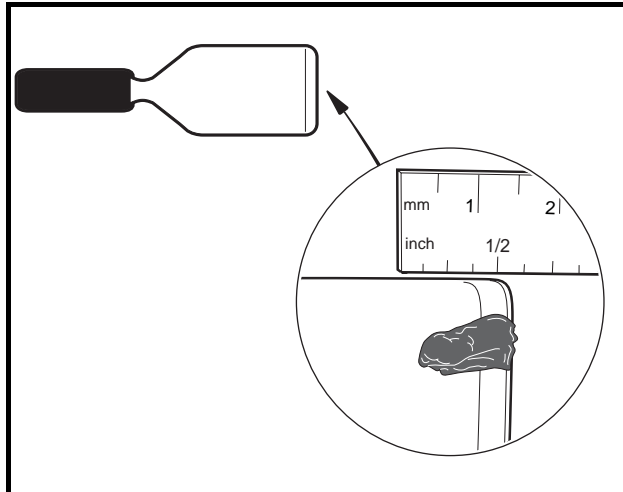


Figure 16-14 Grease on Putty Knife

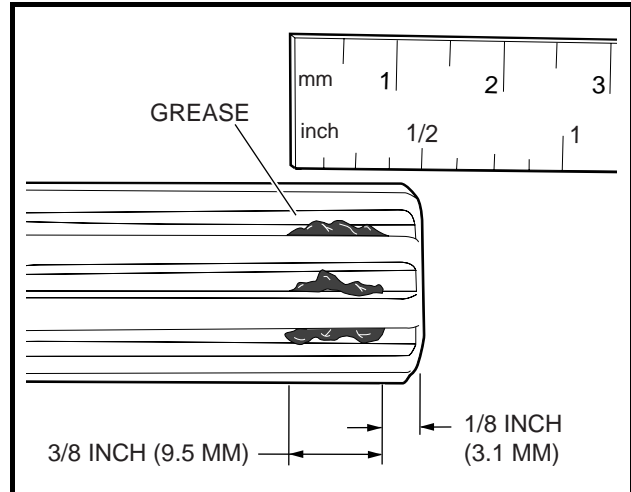


Figure 16-15 Application of grease to Input Shaft Grooves

- 2.6. Check the chamfer and end of the input shaft to ensure these areas are completely clean of grease as shown (Figure 16-16, Page 16-13).
3. Install the molded bumper.
  - 3.1. With the flat side toward the bottom of the coupling, install the molded bumper (30) into the motor coupling (Figure 16-10, Page 16-8). See following NOTE.

**NOTE:** The motor coupling must be new and free of grease and debris.

- 3.2. Ensure that the installed bumper is seated at the bottom of the coupling.
4. Install motor on transaxle.
  - 4.1. Slide the motor coupling onto the transaxle input shaft. See following NOTE.

**NOTE:** The coupling will push any excess grease on the input shaft along the shaft toward the transaxle.

When the motor is pushed onto the input shaft, the motor adapter ring (1) will not bottom out against the transaxle housing (Figure 16-10, Page 16-8). There will be approximately 1/16 inch (1.6 mm) gap between the motor adapter ring and transaxle housing as shown (Figure 16-17, Page 16-13).

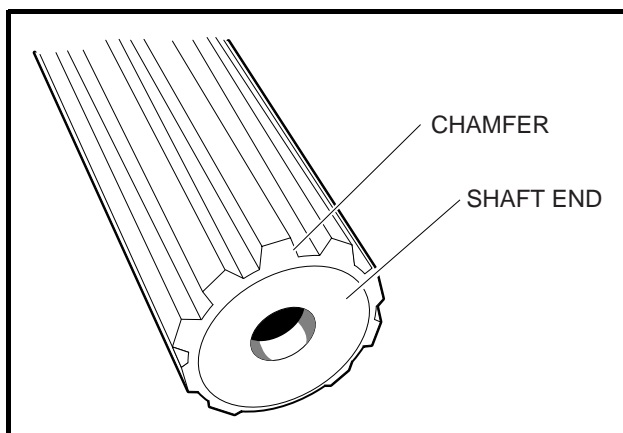


Figure 16-16 Clean Chamfer and Input Shaft End

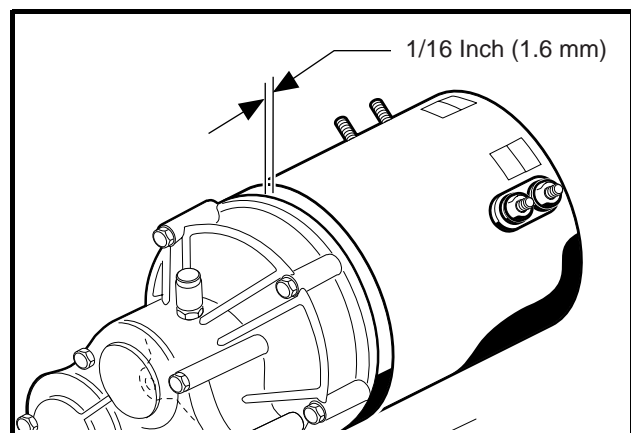


Figure 16-17 Gap at Motor and Transaxle

**Motor Installation, Continued:**

- 4.2. Loosely install four motor bolts and washers that secure the motor to the transaxle. Do not tighten.
- 4.3. Begin finger tightening the bolts in the sequence indicated (**Figure 16-19, Page 16-15**). Continue tightening by hand until the motor is seated in the transaxle housing. **See following CAUTION and NOTE.**

** CAUTION**

- **Make sure the motor is properly seated in the transaxle housing.**

**NOTE:** Failure to install and tighten the motor mounting bolts in the proper sequence and to the proper tightness may result in motor noise during operation.

- 4.4. Tighten the right bolt (1) to 65 in-lb (7.3 N·m).
- 4.5. Tighten the left bolt (2) to 65 in-lb (7.3 N·m).
- 4.6. Tighten the center bolt (3) to 65 in-lb (7.3 N·m) (**Figure 16-19, Page 16-15**).
- 4.7. Tighten the bolt (24) inserted through the tab to 155 in-lb (17.5 N·m) (**Figure 16-18, Page 16-15**).
- 4.8. Install the motor wires, making sure they are connected to the correct motor terminals and that the terminal orientation is correct. **See Wiring Diagram, Section 11, Page 11-10.** Tighten the terminal retaining nuts to 65 in-lb (7.3 N·m).
- 4.9. Secure the white, orange, green, and blue wires with a wire tie so that none of the motor wires will scrub the motor or transaxle when the vehicle is in operation.
- 4.10. Connect the three-pin speed sensor wire to the vehicle wire harness.
5. If using a chain hoist, lower the vehicle and guide the leaf springs into the shackles. If using a floor jack, raise the transaxle until the leaf springs can be guided into the shackles.
6. Insert the mounting bolts through the spring shackles and the bushings in the leaf spring eyes and install lock nuts. Tighten the bolts to 23 ft-lb (31 N·m). **See Section 9 – Rear Suspension in the appropriate maintenance and service manual.**
7. Install the shock absorbers. Tighten nut until rubber bushing expands to the diameter of the cup washer.
8. If removed, install wheels and finger tighten the lug nuts.
9. Lift vehicle and remove jack stands. Lower vehicle to the floor and tighten lug nuts, using a crisscross pattern, to 55 ft-lb (74.6 N·m).
10. Place the Tow/Run switch in the TOW position and connect the batteries, positive (+) cable first. Tighten battery terminals to 110 in-lb (12.4 N·m) and coat terminals with Battery Terminal Protector Spray (CCI P/N 1014305) to minimize corrosion.
11. Place the Tow/Run switch in the RUN position.
12. Inspect the vehicle for proper operation.
  - Make sure that the vehicle operates in the forward direction when the Forward/Reverse switch is in the FORWARD position.
  - Make sure that the vehicle operates in the reverse direction when the Forward/Reverse switch is in the REVERSE position. The reverse buzzer will sound as a warning when the Forward/Reverse switch is in REVERSE.
13. Make sure that the vehicle does not operate when the Forward/Reverse switch is in the NEUTRAL position.



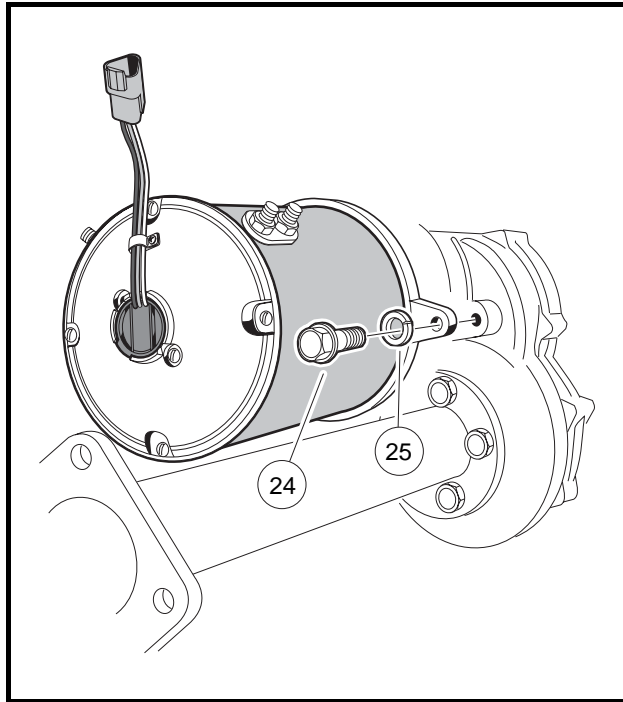


Figure 16-18 Motor Installation

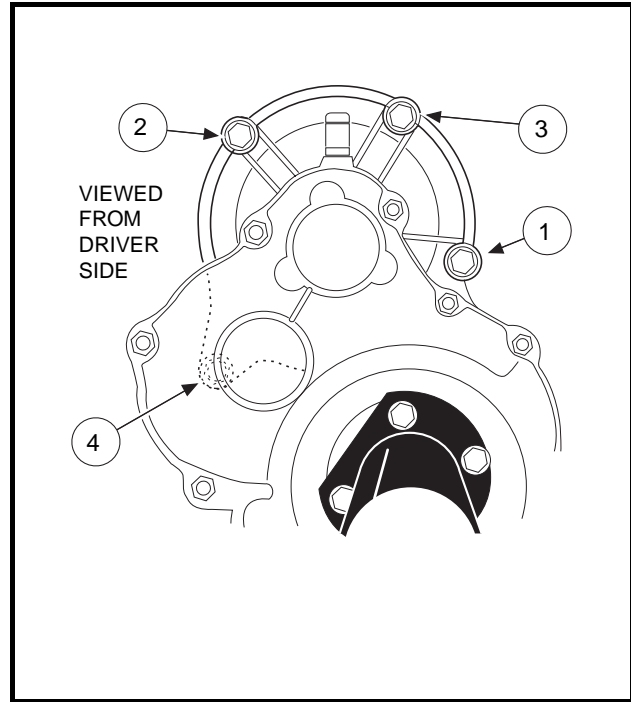


Figure 16-19 Motor Mount

## MOTOR SPEED SENSOR

See General Warning, Section 10, Page 10-1.

### Testing the Motor Speed Sensor

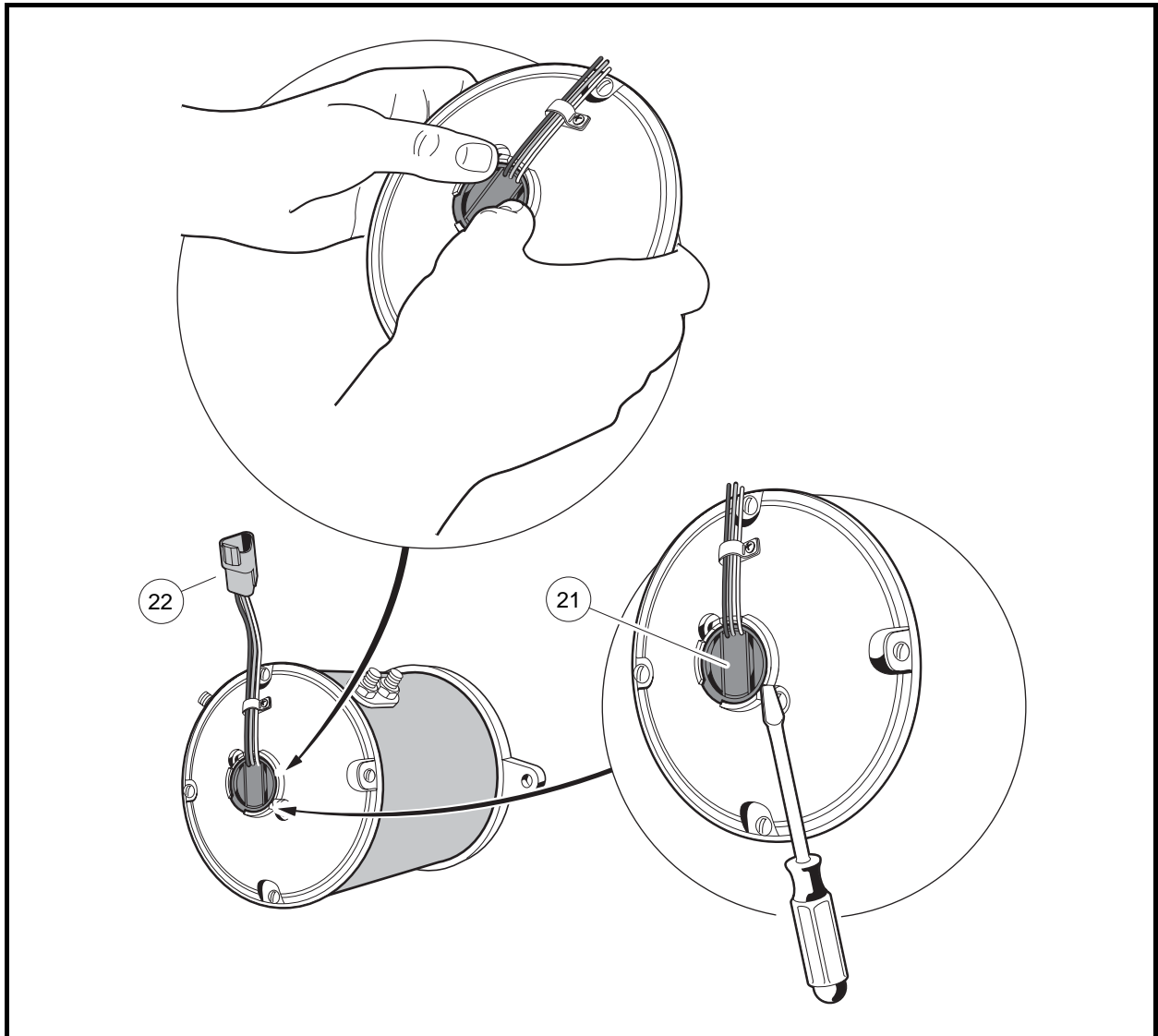
See Test Procedure 13, Section 11, Page 11-36.

### Motor Speed Sensor Removal

1. Disconnect the battery cables as instructed. **See WARNING "To avoid unintentionally starting..." in General Warning, Section 10, Page 10-1.**
2. Disconnect the three-pin connector (22) from the vehicle wire harness (**Figure 16-20, Page 16-16**).
3. Using a screwdriver, gently pry the motor speed sensor (21) from recessed area on the motor end shield.

### Motor Speed Sensor Installation

1. Position the motor speed sensor (21) as shown and firmly press the speed sensor into the motor end shield. Sensor should fit flush against the motor (**Figure 16-20, Page 16-16**).
2. Connect the three-pin connector (22) to the vehicle wire harness.
3. Place the Tow/Run switch in the TOW position and connect the batteries, positive (+) cable first. Tighten battery terminals to 110 in-lb (12.4 N·m) and coat terminals with Battery Terminal Protector Spray (CCI P/N 1014305) to minimize corrosion.

**Motor Speed Sensor Installation, Continued:****Figure 16-20 IQ Motor Speed Sensor**

## SECTION 17A – TRANSAXLE (TYPE G)

---

### **⚠ DANGER**

- See General Warning, Section 10, Page 10-1.

### **⚠ WARNING**

- See General Warning, Section 10, Page 10-1.

## TRANSAXLE IDENTIFICATION

---

Club Car electric vehicles utilize one of two types of transaxles. The different transaxles are identified by the orientation of the gear case bolt heads:

- The Type G transaxle has gear case bolt heads oriented toward the passenger side of the vehicle.
- The Type K transaxle has gear case bolt heads oriented toward the driver side of the vehicle.

Please note that parts used in these transaxles are not interchangeable with one another. Determine which transaxle vehicle is equipped with before proceeding with service.

*This section pertains to Type G transaxles only. For information and procedures on Type K transaxles, proceed to Section 17b – Transaxle (Type K).*

## LUBRICATION

---

**See General Warning, Section 10, Page 10-1.**

There are two plugs located on the lower half of the transaxle housing. The upper plug (21) (as viewed when the vehicle is on a level surface) is used as a lubricant level indicator (**Figure 17a-5, Page 17a-3**). When the vehicle is parked on a level surface, the lubricant level should be even with the bottom of the hole. The lower plug (22) is for draining the lubricant. When draining the lubricant, the upper plug should be removed so the lubricant will drain faster. Be sure the drain plug is reinstalled before filling.

**NOTE:** *Recycle or dispose of used oil or lubricant in accordance with local, state, and federal regulations.*

## AXLE BEARING AND SHAFT

---

**See General Warning, Section 10, Page 10-1.**

### AXLE SHAFT

#### Axle Shaft and Oil Seal Removal

1. Place chocks at the front wheels. Loosen lug nuts on rear wheels and lift the rear of the vehicle with a chain hoist or floor jack. Place jack stands under the axle tubes to support the vehicle.
2. Remove the rear wheel and brake drum. **See Section 6 – Wheel Brake Assemblies and Section 8 – Wheels and Tires in the appropriate maintenance and service manual.**

**Axle Shaft and Oil Seal Removal, Continued:**

3. Using 90° internal snap ring pliers, remove the internal retaining ring (6) from the axle tube (Figure 17a-5, Page 17a-3). See also Figure 17a-1, Page 17a-2.
4. Remove the axle, retaining ring, and bearing assembly by pulling the axle straight out of the housing.
5. If necessary, remove the axle oil seal and adapter ring.
  - 5.1. Use a bearing puller (CCI P/N 1016417) to remove the axle seal and adapter ring from the axle tube (Figure 17a-2, Page 17a-2). See following CAUTION and NOTE.

**⚠ CAUTION**

- Do not scar or damage the inside surfaces of the tube when removing the oil seal and adapter ring. A damaged tube might have to be replaced.

**NOTE:** Do not discard the adapter ring. If the adapter ring is lost or damaged, the axle tube will have to be replaced.

- 5.2. Use a press to separate the axle oil seal (15) from the adapter ring (39) (Figure 17a-3, Page 17a-2). Retain the adapter ring and discard the oil seal.
6. Inspect the axle shaft assembly to be sure the bearing and collar have not slipped and are still seated against the shoulder on the axle shaft.
7. Inspect bearing (5) (Figure 17a-5, Page 17a-3). If the bearing in a Type G transaxle is worn or damaged, the entire axle shaft assembly (1 or 2) must be replaced.

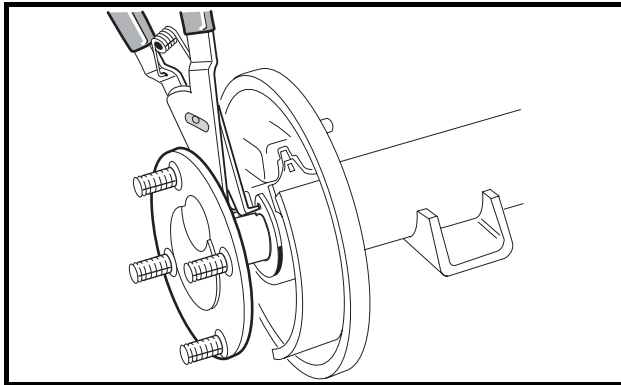


Figure 17a-1 Axle Tube

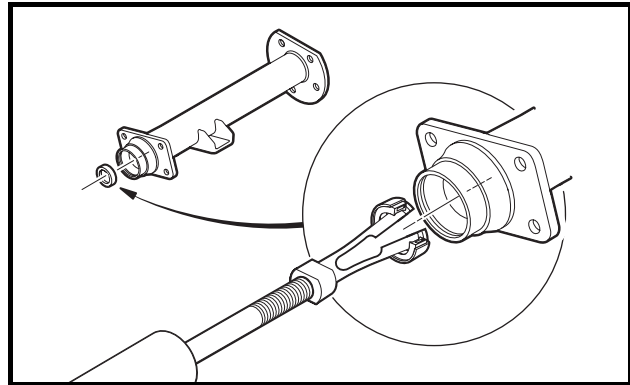


Figure 17a-2 Axle Seal and Adapter Ring Removal

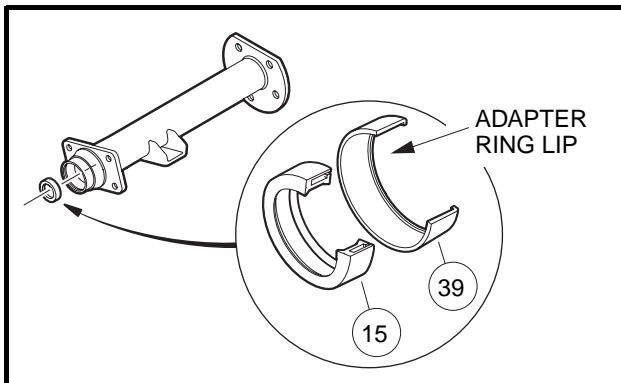


Figure 17a-3 Axle Seal and Adapter Ring

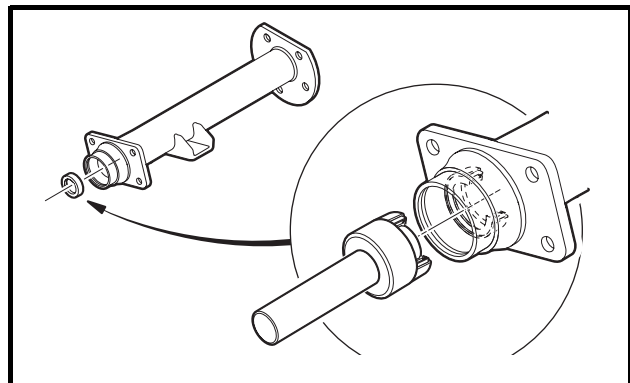


Figure 17a-4 Axle Seal and Adapter Ring Installation

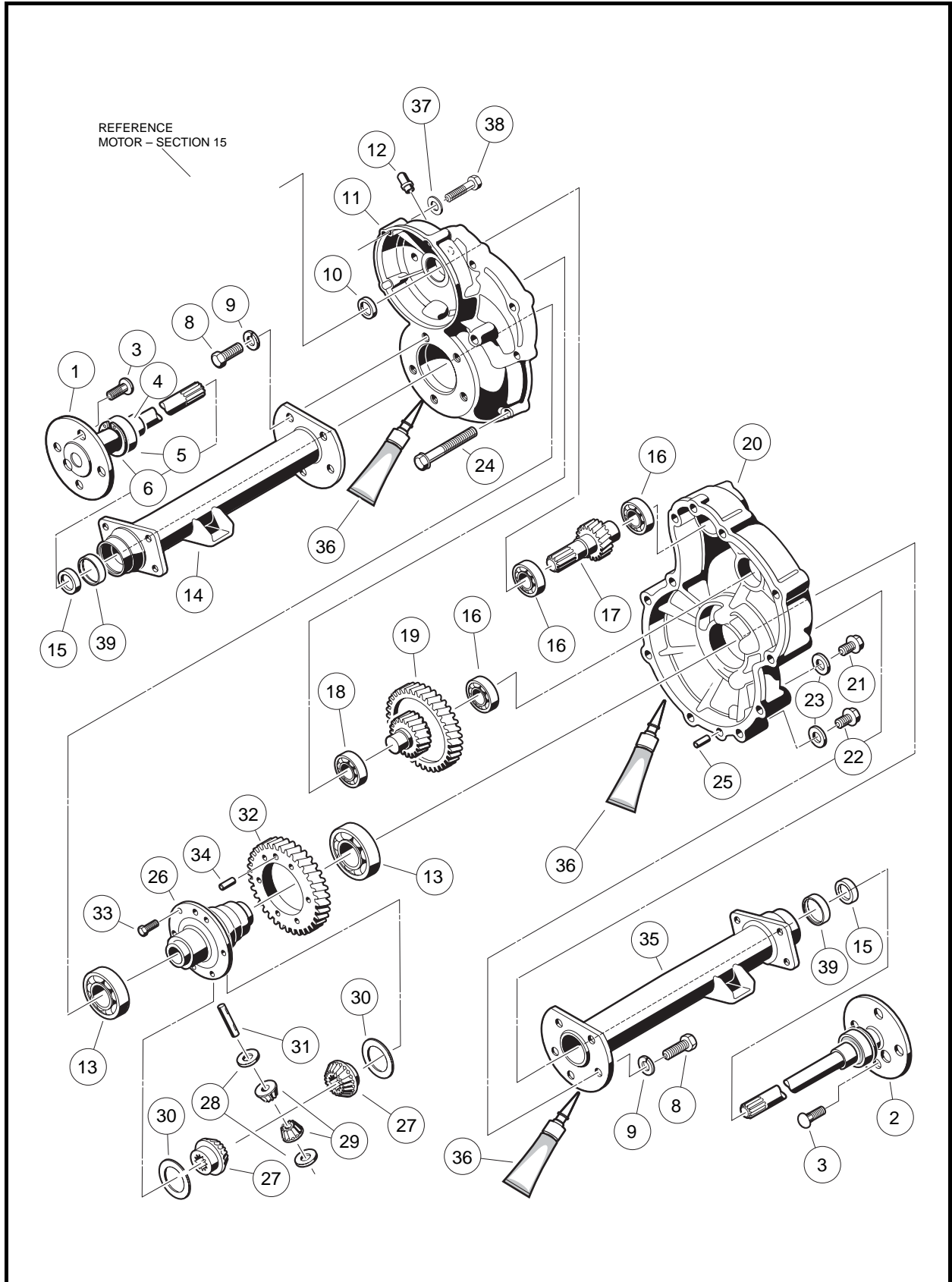


Figure 17a-5 Transaxle – Type G

## Axle Shaft and Oil Seal Installation

1. If previously removed, install a new oil seal.
  - 1.1. Clean seal seat in the adapter ring (39) (**Figure 17a-3, Page 17a-2**).
  - 1.2. Place a new seal (15) in the adapter ring with the seal lip facing toward the adapter ring lip (**Figure 17a-3, Page 17a-2**). Use an axle seal tool (CCI P/N 1014162) and mallet to tap it in until it seats firmly in position (**Figure 17a-3, Page 17a-2**). A hydraulic press may also be used with the axle seal tool.
  - 1.3. Clean adapter ring seat(s) in the axle tube (14 or 35) (**Figure 17a-5, Page 17a-3**).
  - 1.4. Apply Loctite<sup>®</sup> 603 to the outer diameter of the adapter ring.
  - 1.5. Place the oil seal and adapter ring assembly into the axle tube with the seal lip facing away from the bearing (**Figure 17a-4, Page 17a-2**). Use an axle seal tool (CCI P/N 1014162) and mallet to tap it in until it seats firmly in position.

### **⚠ CAUTION**

- **Clean any residual oil from the exposed end of the axle shaft and from the oil seal area prior to installing the axle shaft.**
2. Clean the shaft splines and then insert the shaft, splined end first, through the seal and into the axle tube. Be careful not to damage the seal. Then advance the shaft through the inner bearing and rotate it to align the shaft splines with the splined bore of the differential side gear (27) (**Figure 17a-5, Page 17a-3**). Continue advancing the shaft until the bearing seats against the axle tube shoulder.
  3. Use a pair of snap ring pliers to install the retaining ring (6) inside axle tube (**Figure 17a-5, Page 17a-3**).

**NOTE:** *If the retaining ring (6), axle bearing (5), or sleeve (4) must be replaced, the entire axle shaft assembly (1 or 2) must be replaced (**Figure 17a-5, Page 17a-3**).*

4. Place a 1/4 to 3/8-inch (6 to 10 mm) diameter rod against the retaining ring and tap lightly at four to five locations around the retaining ring to ensure it is properly seated. **See following WARNING.**

### **⚠ WARNING**

- **Be sure the retaining ring is properly seated in its groove. If the ring is not properly installed, the axle assembly will separate from the transaxle and damage the axle assembly and other components. Loss of vehicle control could result, causing severe personal injury.**
5. If a new oil seal was installed, allow 24 hours before operating the vehicle to allow the Loctite<sup>®</sup> 603 to fully cure.

## AXLE BEARING

Do not remove the axle bearing (5) from a Type G transaxle. If bearing is worn or damaged, the entire axle assembly (1 or 2) must be replaced (**Figure 17a-5, Page 17a-3**).

## TRANSAXLE

**See General Warning, Section 10, Page 10-1.**

## TRANSAXLE REMOVAL

1. Place chocks at the front wheels and slightly loosen lug nuts on both rear wheels.
2. Place a floor jack under the transaxle and raise the rear of the vehicle. Position jack stands under the frame crossmember between the spring mount and the side stringer, just forward of each rear wheel. Lower the vehicle to let the jack stands support the vehicle (**Figure 17a-6, Page 17a-5**).
3. Remove the rear wheels, then thread one lug nut onto a stud on each rear hub. This will keep the brake drums on the hubs.
4. Remove the cotter pins (1), brake cable clevis pins (2), and cable retaining E-clips (3). Disconnect the brake cables (4) (**Figure 17a-7, Page 17a-5**).

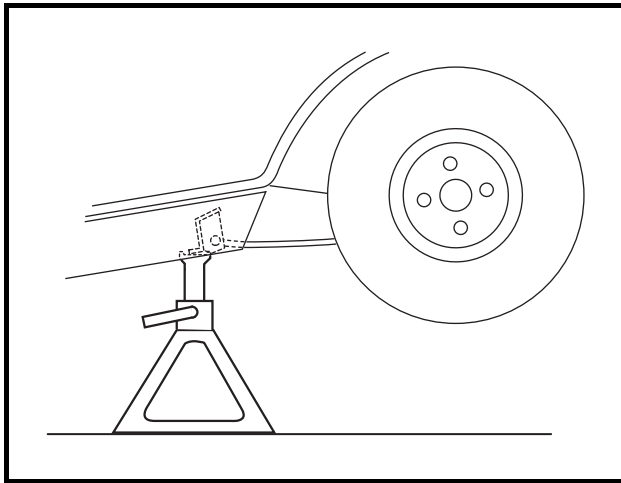


Figure 17a-6 Vehicle Supported on Jack Stands

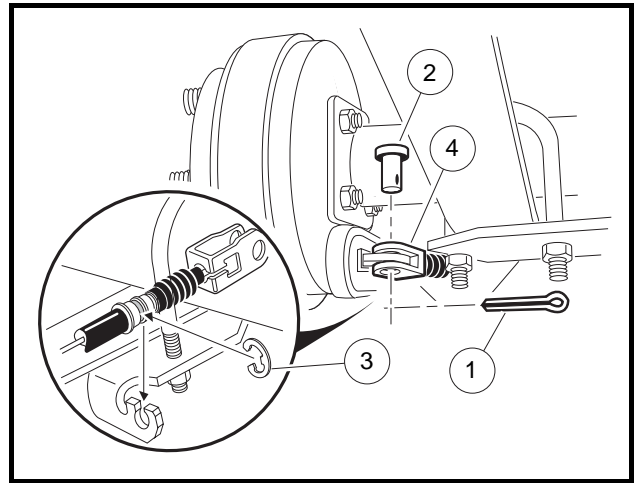


Figure 17a-7 Disconnect Brakes

5. Disconnect the shock absorbers from their lower mounts (**Figure 17a-8, Page 17a-5**).
6. Disconnect the four motor wires. Use two wrenches to prevent the post from turning.
7. With a floor jack supporting the transaxle, remove lower spring shackle nuts and bolts. Position shackles so they are clear of springs (**Figure 17a-9, Page 17a-5**).

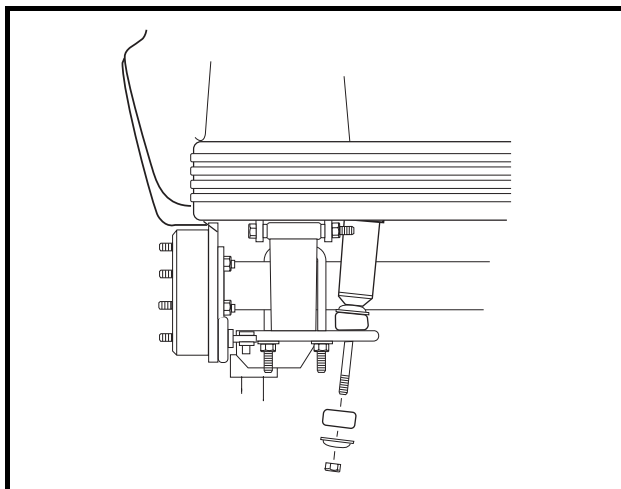


Figure 17a-8 Disconnect Shocks

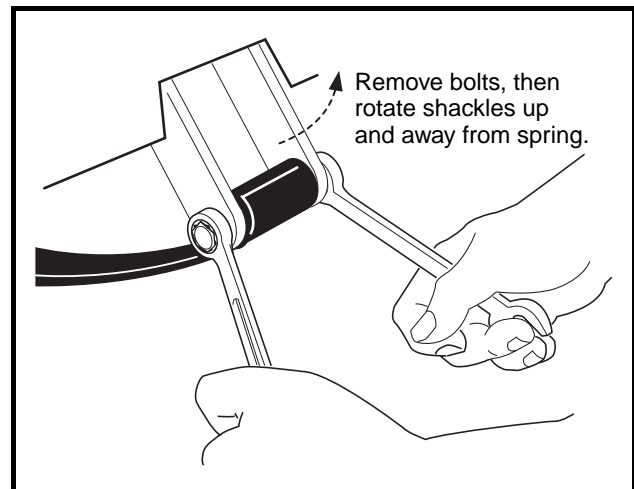


Figure 17a-9 Shackles

**Transaxle Removal, Continued:**

8. If a chain hoist was used to raise the vehicle, lift the vehicle high enough to permit easy access and clearance for removal of the motor. If a floor jack was used to raise the vehicle, lower the transaxle enough to permit easy access and clearance for removal of the motor.
9. Remove the three motor mounting bolts (Figure 17a-11, Page 17a-6), and the motor positioning bolt (Figure 17a-12, Page 17a-7), mounting the motor to the transaxle. **See following WARNING.**

**⚠ CAUTION**

- Do not position fingers under motor when sliding motor off of the input shaft. Fingers may get pinched when motor disengages.

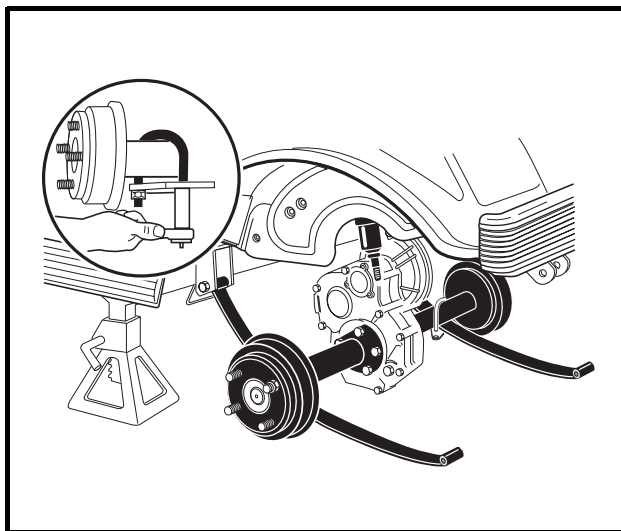


Figure 17a-10 Leaf Springs

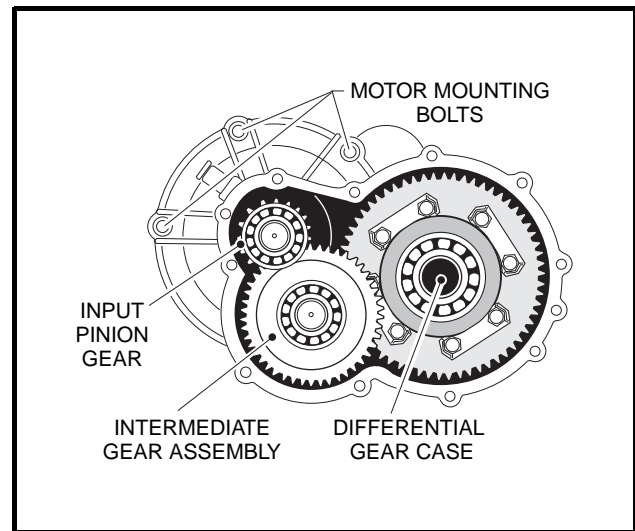


Figure 17a-11 Motor Mounting Bolts

10. Carefully remove the motor from the transaxle. Slide the motor away from the transaxle until the motor spline becomes disengaged from the input shaft, then lift motor out. **See preceding WARNING.**
11. If a floor jack was used, pull floor jack from beneath the transaxle and allow the springs to rest on the floor.
12. Remove the U-bolts attaching the transaxle to the leaf springs (Figure 17a-10, Page 17a-6).
13. Carefully lift each end of the transaxle off its positioning pin (on the leaf spring) and slide the transaxle to the rear and out of the vehicle.
14. Drain the lubricant from the transaxle and remove the axle shafts. **See Axle Shaft and Oil Seal Removal on page 17a-1. See following NOTE.**

**NOTE:** Recycle or dispose of used oil or lubricant in accordance with local, state, and federal regulations.

15. Remove the brake assemblies if required. **See Section 6 – Wheel Brake Assemblies in the appropriate maintenance and service manual.**



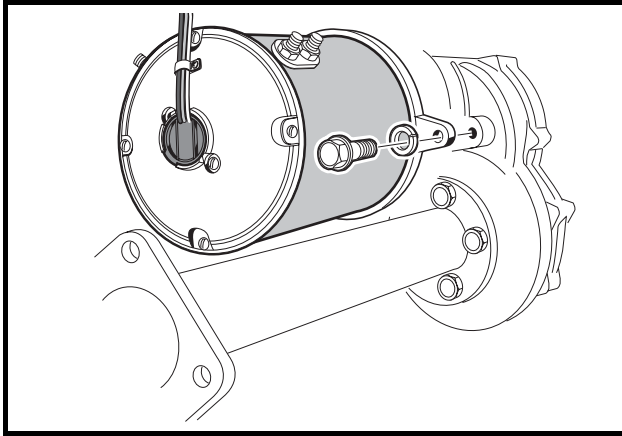


Figure 17a-12 Motor Positioning Bolt

## TRANSAXLE DISASSEMBLY, INSPECTION, AND ASSEMBLY

See General Warning, Section 10, Page 10-1.

### TRANSAXLE DISASSEMBLY AND INSPECTION

1. To detach axle tubes (14 and 35) from the transaxle housing, remove the bolts and lock washers (8 and 9) (Figure 17a-5, Page 17a-3).
2. Remove 11 bolts (24) that hold housing together.
3. Pull the halves of the housing (11 and 20) apart. If necessary, tap lightly on the spline of the input pinion (17). See following CAUTION.

#### **⚠ CAUTION**

- To prevent damage to the housing mating seal surfaces, use caution when separating halves.

4. Remove input pinion gear (17) by pulling gear out while rocking intermediate gear assembly (19). Lift intermediate gear assembly and differential gear case unit out simultaneously (Figure 17a-5, Page 17a-3). See following CAUTION.

#### **⚠ CAUTION**

- Do not damage gears. Use extreme care when handling them.

5. Use a bearing puller or arbor press to remove bearings (16) from the input pinion gear. If the oil seal (10) is damaged, replace it (Figure 17a-5, Page 17a-3). See also Figure 17a-13, Page 17a-8. See following CAUTION.

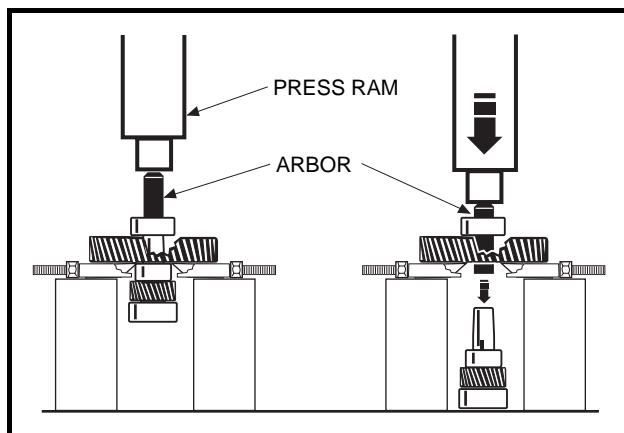
#### **⚠ CAUTION**

- Do not reuse bearings after removing them. Replace bearings with new ones.

6. To disassemble the intermediate gear assembly, press off together the bearing (16) and the gear (19) (Figure 17a-5, Page 17a-3). See also Figure 17a-13, Page 17a-8.

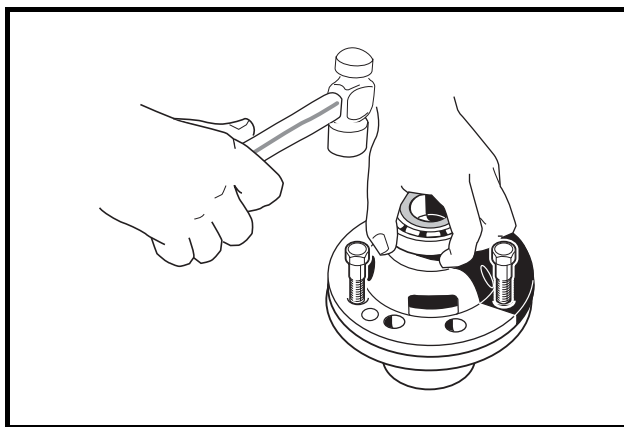
**Transaxle Disassembly and Inspection, Continued:**

7. Press the bearing (18) off the intermediate gear assembly (**Figure 17a-5, Page 17a-3**).



**Figure 17a-13 Intermediate Gear Assembly**

8. Disassemble the differential gear case:
- 8.1. Remove four hex bolts (33) that secure the ring gear to the differential case (**Figure 17a-5, Page 17a-3**).
  - 8.2. Remove the ring gear. Retain dowel pin (34) from between the ring gear and differential case for reassembly.
  - 8.3. Separate the differential gear case housing. If necessary, reinstall two of the hex bolts (removed previously in step 8.1.) into the differential gear unit and, while holding the unit slightly above the work area, lightly tap the bolt heads (**Figure 17a-14, Page 17a-8**). Remove the two bolts.



**Figure 17a-14 Separate Housing**

- 8.4. Remove the differential pin (31) by pushing pin through differential gear case from one side (**Figure 17a-5, Page 17a-3**). See also **Figure 17a-15, Page 17a-9**.
- 8.5. Remove the idler gears and thrust plates (1 and 2) (**Figure 17a-16, Page 17a-9**).

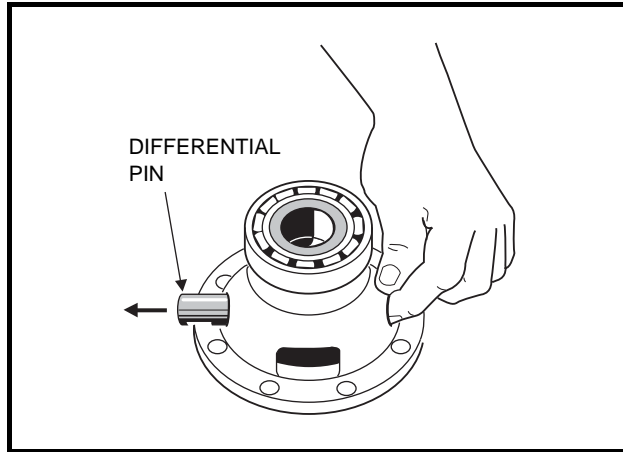


Figure 17a-15 Differential Pin

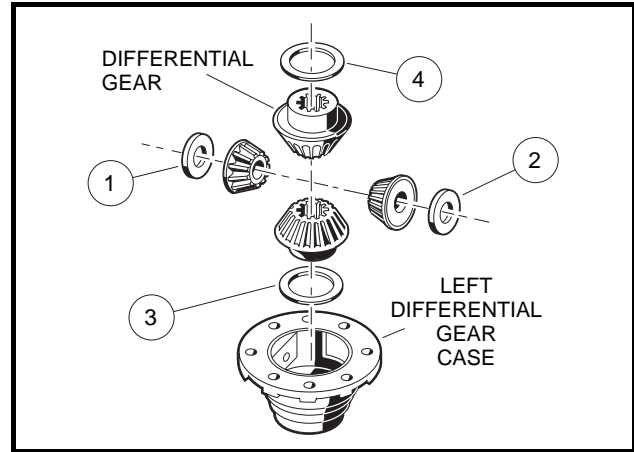


Figure 17a-16 Left Differential

8.6. Remove the differential gears and thrust plates (3 and 4).

8.7. Inspect the bearings (13) of the differential case (26) and replace them if they are damaged (**Figure 17a-5, Page 17a-3**). To remove them, press them off. **See following CAUTION.**

### **⚠ CAUTION**

- Do not reuse bearings after removing them. Replace bearings with new ones.

9. Inspect parts for wear or damage. Any worn or damaged parts should be replaced. **See following NOTE.**

**NOTE:** Damaged or worn gears should be replaced as sets.

## TRANSAXLE ASSEMBLY

### **⚠ CAUTION**

- Do not press against the bearing outer race.
- The housing and all parts must be wiped clean and dry before reassembly.

1. If bearings (13) were removed during disassembly, install new bearings using an arbor press (**Figure 17a-5, Page 17a-3**).
2. Assemble the differential gear case.
  - 2.1. Install the pin (31) (**Figure 17a-5, Page 17a-3**). Apply a small amount of oil to all thrust plates and to both ends of the pin.
  - 2.2. Install four hex bolts (33) and output gear (32). Tighten bolts to 51 ft-lb (69 N·m).
3. Press a new bearing (18) onto the intermediate gear assembly (**Figure 17a-5, Page 17a-3**).
4. Press new bearing (16) onto input pinion gear (17).
5. Apply grease to the lip of the new oil seal (10) and install the seal using a transaxle pinion seal tool (CCI P/N 1014161). The lip of the oil seal should face the inside of the transaxle housing. Make sure the seal is firmly seated.
6. Install the differential assembly, the intermediate gear assembly, and the input pinion gear simultaneously. Be sure all bearings are seated properly in the housing. Rotate the input shaft to check for smooth gear operation (**Figure 17a-11, Page 17a-6**).

**Transaxle Assembly, Continued:**

7. Install both dowel pins (25) in the transaxle housing (20) **(Figure 17a-5, Page 17a-3)**.
8. Install left half of transaxle housing:
  - 8.1. Place a 1/8-inch (3 mm) bead of Three Bond liquid gasket on mating surface of housing.
  - 8.2. Install left half of transaxle housing (20) **(Figure 17a-5, Page 17a-3)**.
  - 8.3. Install eleven bolts (24) in the case housing and tighten to 19 ft-lb (25.7 N·m). Type G transaxles have no shims or gasket.
  - 8.4. Install axle tube (14 and 35) with lock washers and bolts (9 and 8) **(Figure 17a-5, Page 17a-3)**. Tighten the bolts to 36 ft-lb (49 N·m).
9. Install the brake assemblies as instructed. **See Section 6 – Wheel Brake Assemblies in the appropriate maintenance and service manual.**
10. Apply a small amount of grease to the lip of the oil seal (15) **(Figure 17a-5, Page 17a-3)**.

** CAUTION**

- **Clean any residual oil from the exposed end of the axle shaft and from the oil seal area prior to installing the axle shaft.**
11. Clean the splines on the axle shaft (1 and 2). Rotate the axle to align the shaft splines with the splined bore of the differential side gear. Push the shaft in until the bearing seats against the shoulder in the axle tube.
  12. Install the retaining ring (6) in the axle tube. **See following WARNING.**

** WARNING**

- **Be sure the retaining ring is properly seated in its groove. If the ring is not properly installed, the axle assembly will separate from the transaxle and damage the axle assembly and other components. Loss of vehicle control could result, causing severe personal injury.**
13. Make sure the drain plug (22) is installed in the transaxle and tightened to 23 ft-lb (31 N·m). Fill the transaxle, through the level indicator hole, with 22 ounces of SAE 30 API Class SE, SF, or SG oil (a higher grade may also be used). Install and tighten the level indicator plug (21) to 23 ft-lb (31 N·m).

**TRANSAXLE INSTALLATION****See General Warning, Section 10, Page 10-1.**

1. If using a chain hoist, raise the vehicle and place transaxle in position on the jack stands. If using a floor jack, lower the jack stands to their lowest settings and place the transaxle in position on the jack stands.
2. Align the center hole in the saddle of the transaxle with the pilot bolt in the leaf spring assembly.
3. Install the two U-bolts, jounce bumper mount and spacers, lock washers, and nuts. Tighten the nuts to 25 ft-lb (34 N·m). Tighten the U-bolt nuts so an equal amount of thread is visible on each leg of the bolt.
4. Install the motor. **See Section 16 – Motor.**
5. If using a chain hoist, lower the vehicle while guiding the leaf springs into the rear spring shackles. If using a floor jack, raise the differential while guiding the leaf springs into the rear spring shackles. Then raise the jack stands to support the transaxle.

6. Connect the four motor wires. Tighten the retaining nuts to 65 in-lb (7.3 N·m). Use two wrenches to prevent the posts from turning. **See following NOTE.**

**NOTE:** *If the motor wires were not tagged when disconnected, refer to the wiring diagram for proper connection. See **Wiring Diagram, Section 11, Page 11-10.***

7. Insert bolts through the spring shackles and bushings in the leaf spring eyes. Secure bolts with lock nuts. Tighten to 15 ft-lb (20.3 N·m).
8. Connect the brake cables.
9. Install the shock absorbers. Tighten shock absorber retaining nuts until the rubber bushings expand to the same size as the cup washers.
10. Install the rear wheels and finger-tighten the lug nuts.
11. Lift the vehicle and remove the jack stands.
12. Lower vehicle and tighten the lug nuts, using a crisscross pattern, to 55 ft-lb (74.6 N·m).
13. Test drive the vehicle to check for proper operation.



## SECTION 17B – TRANSAXLE (TYPE K)

---

### **⚠ DANGER**

- See General Warning, Section 10, Page 10-1.

### **⚠ WARNING**

- See General Warning, Section 10, Page 10-1.

## TRANSAXLE IDENTIFICATION

---

Club Car electric vehicles utilize one of two types of transaxles. The different transaxles are identified by the orientation of the gear case bolt heads:

- The Type G transaxle has gear case bolt heads oriented toward the passenger side of the vehicle.
- The Type K transaxle has gear case bolt heads oriented toward the driver side of the vehicle.

Please note that parts used in these transaxles are not interchangeable with one another. Determine which transaxle vehicle is equipped with before proceeding with service.

*This section pertains to Type K transaxles only.* For information and procedures on Type G transaxles, go to Section 17a – Transaxle (Type G).

## LUBRICATION

---

**See General Warning, Section 10, Page 10-1.**

There are two plugs located on the lower half of the transaxle housing. The upper plug (25) (as viewed when the vehicle is on a level surface) is used as a lubricant level indicator (**Figure 17b-4, Page 17b-3**). When the vehicle is parked on a level surface, the lubricant level should be even with the bottom of the hole. The lower plug (44) is for draining the lubricant. When draining the lubricant, the upper plug should be removed so the lubricant will drain faster. Be sure the drain plug is reinstalled before filling.

**NOTE:** *Recycle or dispose of used oil or lubricant in accordance with local, state, and federal regulations.*

## AXLE BEARING AND SHAFT

---

**See General Warning, Section 10, Page 10-1.**

### AXLE SHAFT

#### Axle Shaft and Oil Seal Removal

1. Place chocks at the front wheels. Loosen lug nuts on rear wheels and lift the rear of the vehicle with a chain hoist or floor jack. Place jack stands under the axle tubes to support the vehicle.
2. Remove the rear wheel and brake drum. **See Section 6 – Wheel Brake Assemblies and Section 8 – Wheels and Tires in the appropriate maintenance and service manual.**

**Axle Shaft and Oil Seal Removal, Continued:**

- Using 90° internal snap ring pliers, remove the internal retaining ring (6) from the axle tube (Figure 17b-4, Page 17b-3). See also Figure 17b-1, Page 17b-2.
- Remove the axle, retaining ring, and bearing assembly by pulling the axle straight out of the housing.
- Use a 16 inch (40 cm) rolling wedge bar (Figure 17b-2, Page 17b-2) to remove oil seal. Insert the wedge bar underneath the seal lip and pry out oil seal (17) (Figure 17b-3, Page 17b-2). See following CAUTION.

**⚠ CAUTION**

- Do not scar or damage the inside surfaces of the tube when removing the oil seal. A damaged tube might have to be replaced.
- Inspect the axle shaft assembly to be sure the bearing and collar have not slipped and are still seated against the shoulder on the axle shaft.
  - Inspect bearing (5) (Figure 17b-4, Page 17b-3). If the bearing is worn or damaged, replace it.

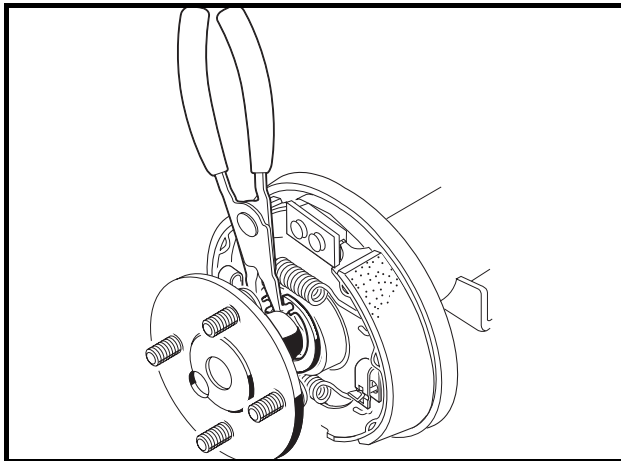


Figure 17b-1 Axle Tube

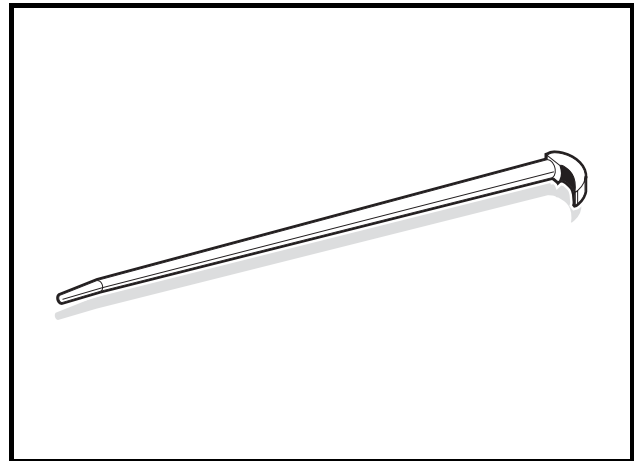


Figure 17b-2 Rolling Wedge Bar

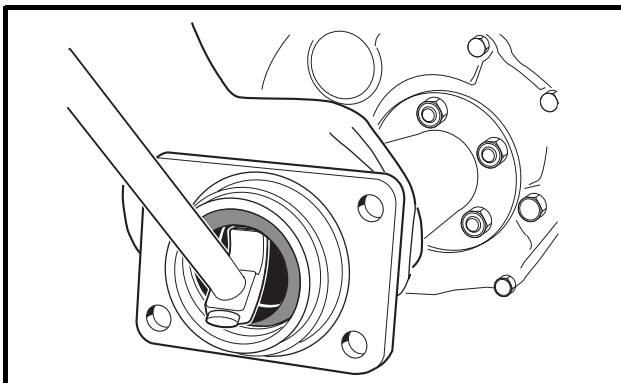


Figure 17b-3 Seal Lip



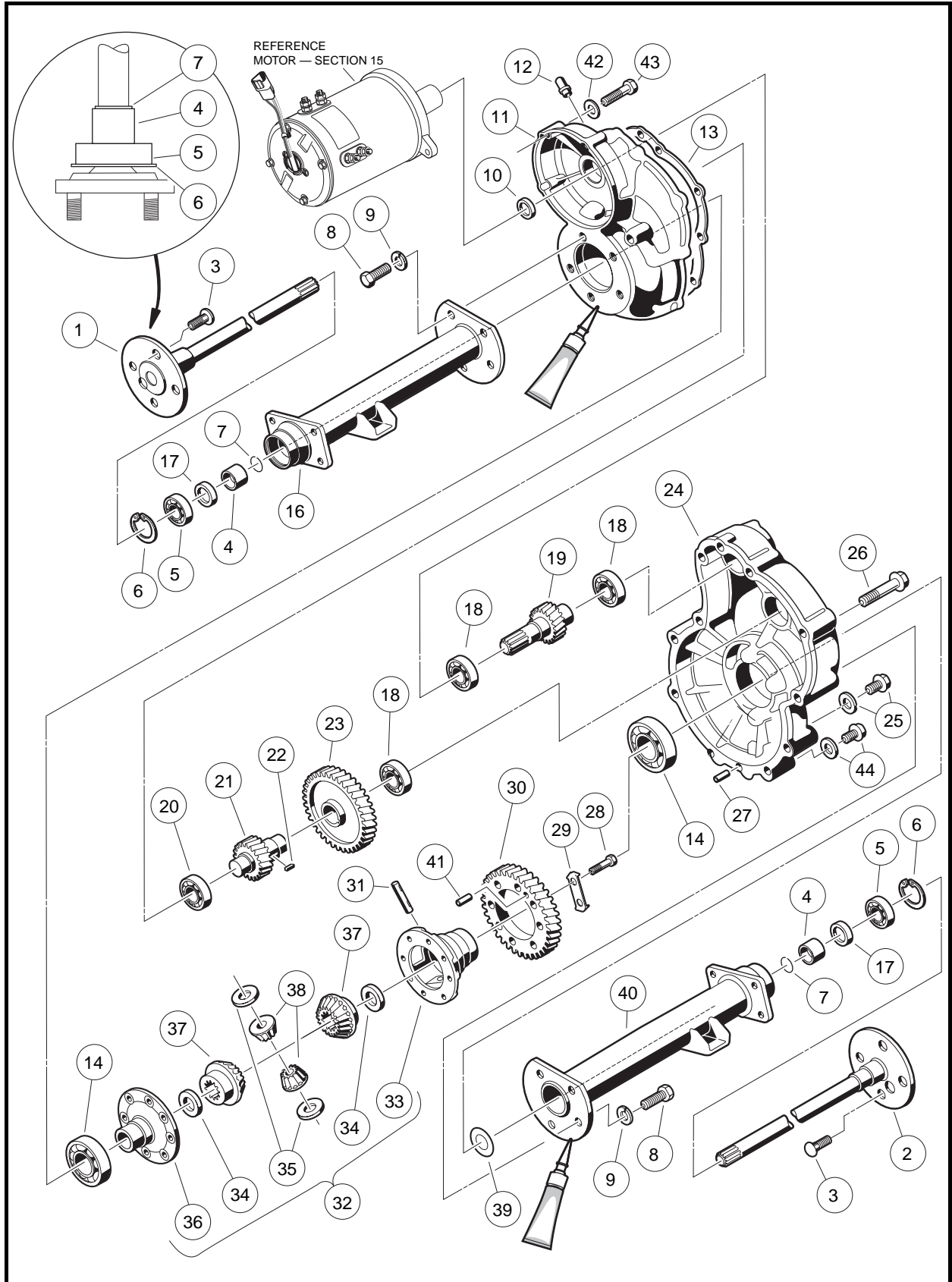


Figure 17b-4 Transaxle – Type K

## AXLE BEARING

### Axle Bearing Removal

1. Remove the retaining ring (7) from the axle shaft (**Figure 17b-4, Page 17b-3**).
2. Place a bearing puller wedge attachment (CCI P/N 1012812) on the axle shaft between the wheel mounting flange and the bearing.
3. Press bearing (5) and collar (4) off together (**Figure 17b-5, Page 17b-4**). See following **CAUTION**.

### **CAUTION**

- Do not tighten the bearing puller wedge attachment against the axle shaft. This could damage the axle shaft when pressing off the bearing and collar.

**NOTE:** It may be necessary to heat the collar before the collar can be removed.

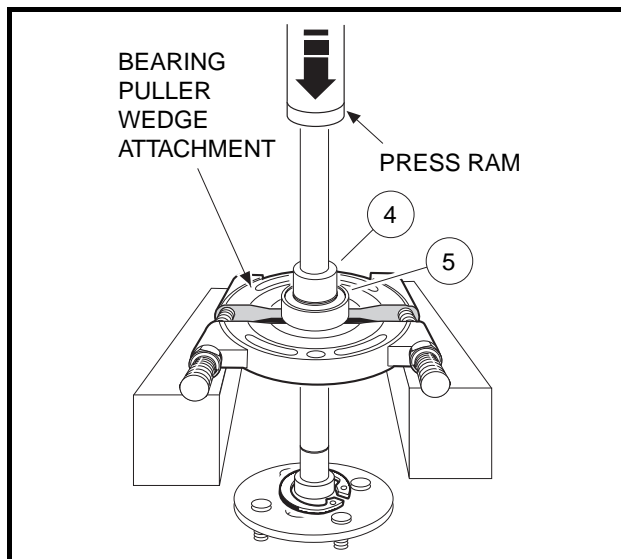


Figure 17b-5 Bearing and Collar

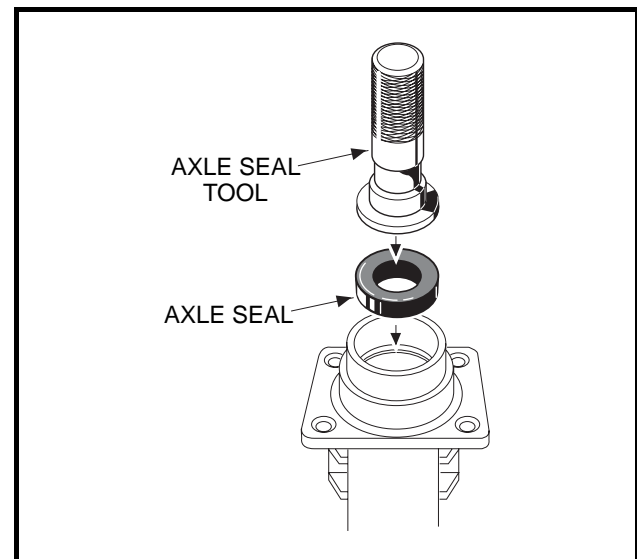


Figure 17b-6 Axle Seal Tool

### Axle Bearing Installation

1. If removed, place retaining ring (6) on axle shaft (1 or 2) (**Figure 17b-4, Page 17b-3**). The retaining ring will be loose on the axle shaft until it is installed into the axle tube.
2. Apply two drops of Loctite<sup>®</sup> 271 to the inside of the collar.

### **CAUTION**

- Apply Loctite<sup>®</sup> 271 to inside of collar only, not to the shaft, so the Loctite will be pushed away from the bearing as the collar and bearing are pressed on. If Loctite gets on or in the bearing, the bearing must be replaced.
  - The collar should be removed no more than two times. If a bearing is removed a third time, the shaft and collar will not give a proper fit.
3. Place the bearing and the collar on the shaft (note, this is a sealed bearing). See following **CAUTION**.

### **⚠ CAUTION**

- If the bearing was removed from the shaft, replace bearing with a new one.

4. Place the bearing puller wedge attachment against the collar and press on both the bearing and collar. See following CAUTION.

### **⚠ CAUTION**

- Do not tighten the bearing puller wedge attachment against the axle shaft. This could damage the axle shaft when pressing off the bearing and collar.

5. Install retaining ring (7) into the groove on the axle shaft (Figure 17b-4, Page 17b-3).

## **Axle Shaft and Oil Seal Installation**

1. Clean bearing and seal seats in the axle tube (16 or 40) (Figure 17b-4, Page 17b-3).
2. Place a new seal (17) in the axle tube with the seal lip facing away from the bearing. Use an axle seal tool (CCI P/N 1014162) and mallet to tap it in until it seats firmly in position (Figure 17b-6, Page 17b-4). A hydraulic press may also be used with the axle seal tool.

### **⚠ CAUTION**

- Clean any residual oil from the exposed end of the axle shaft and from the oil seal area prior to installing the axle shaft.

3. Clean the shaft splines and then insert the shaft, splined end first, through the seal and into the axle tube. Be careful not to damage the seal. Then advance the shaft through the inner bearing and rotate it to align the shaft splines with the splined bore of the differential side gear (37) (Figure 17b-4, Page 17b-3). Continue advancing the shaft until the bearing seats against the axle tube shoulder.
4. Use a pair of snap ring pliers to install the retaining ring (6) inside axle tube (Figure 17b-4, Page 17b-3).
5. Place a 1/4 to 3/8-inch (6 to 10 mm) diameter rod against the retaining ring and tap lightly at four to five locations around the retaining ring to ensure it is properly seated. See following WARNING.

### **⚠ WARNING**

- Be sure the retaining ring is properly seated in its groove. If the ring is not properly installed, the axle assembly will separate from the transaxle and damage the axle assembly and other components. Loss of vehicle control could result, causing severe personal injury.

## **TRANSAXLE**

See General Warning, Section 10, Page 10-1.

## **TRANSAXLE REMOVAL**

1. Place chocks at the front wheels and slightly loosen lug nuts on both rear wheels.

**Transaxle Removal, Continued:**

2. Place a floor jack under the transaxle and raise the rear of the vehicle. Position jack stands under the frame crossmember between the spring mount and the side stringer, just forward of each rear wheel. Lower the vehicle to let the jack stands support the vehicle (**Figure 17b-7, Page 17b-6**).
3. Remove the rear wheels, then thread one lug nut onto a stud on each rear hub. This will keep the brake drums on the hubs.
4. Remove the cotter pins (1), brake cable clevis pins (2), and cable retaining E-clips (3). Disconnect the brake cables (4) (**Figure 17b-8, Page 17b-6**).

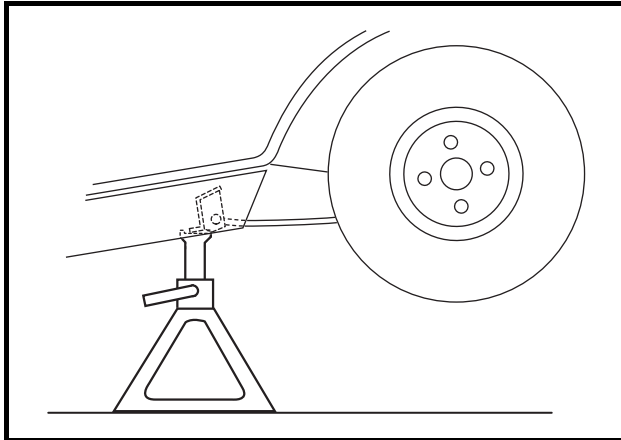


Figure 17b-7 Vehicle Supported on Jack Stands

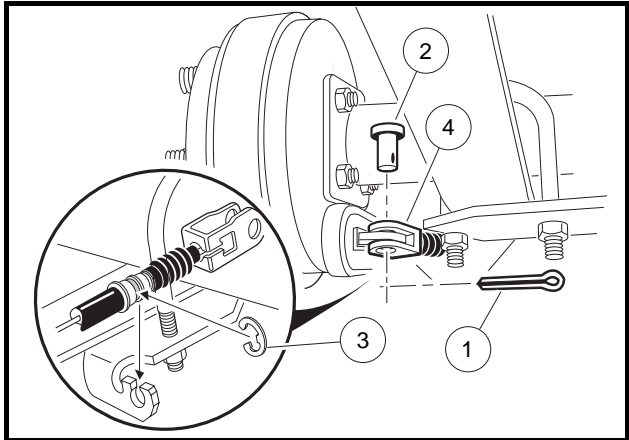


Figure 17b-8 Disconnect Brakes

5. Disconnect the shock absorbers from their lower mounts (**Figure 17b-9, Page 17b-6**).
6. Disconnect the four motor wires. Use two wrenches to prevent the post from turning.
7. With a floor jack supporting the transaxle, remove lower spring shackle nuts and bolts. Position shackles so they are clear of springs (**Figure 17b-10, Page 17b-6**).

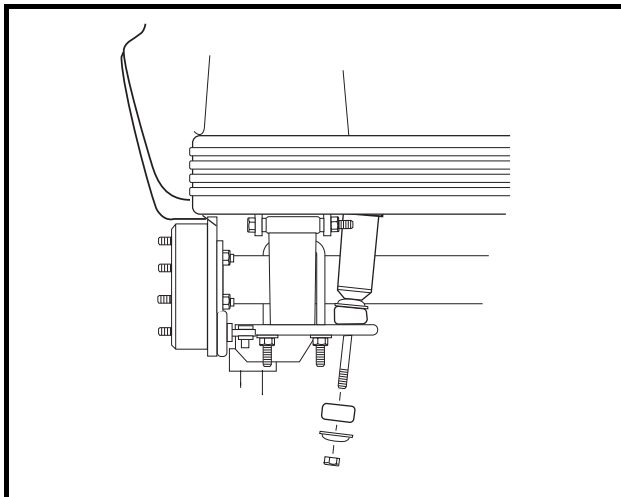


Figure 17b-9 Disconnect Shocks

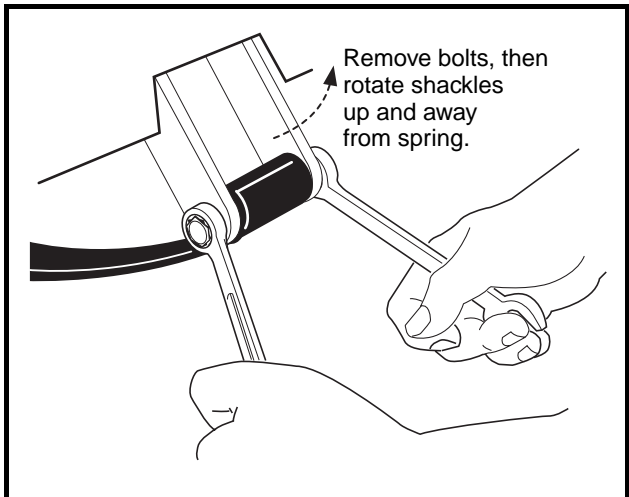
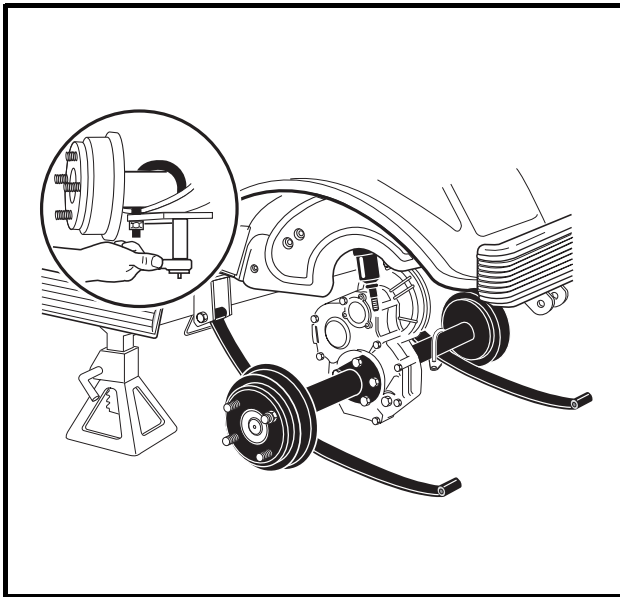


Figure 17b-10 Shackles

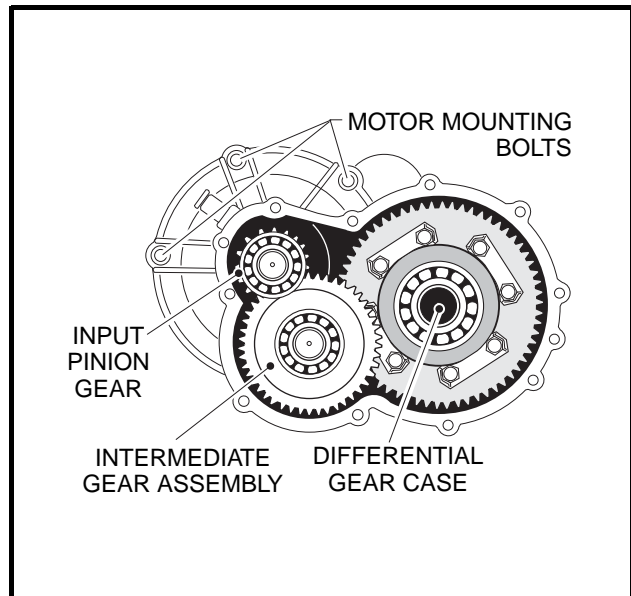
8. If a chain hoist was used to raise the vehicle, lift the vehicle high enough to permit easy access and clearance for removal of the motor. If a floor jack was used to raise the vehicle, lower the transaxle enough to permit easy access and clearance for removal of the motor.
9. Remove the three motor mounting bolts (**Figure 17b-12, Page 17b-7**), and the motor positioning bolt (**Figure 17b-13, Page 17b-8**), mounting the motor to the transaxle. **See following WARNING.**

### **⚠ CAUTION**

- **Do not position fingers under motor when sliding motor off of the input shaft. Fingers may get pinched when motor disengages.**



**Figure 17b-11 Leaf Springs**



**Figure 17b-12 Motor Mounting Bolts**

10. Carefully remove the motor from the transaxle. Slide the motor away from the transaxle until the motor spline becomes disengaged from the input shaft, then lift motor out. **See preceding WARNING.**
11. If a floor jack was used, pull floor jack from beneath the transaxle and allow the springs to rest on the floor.
12. Remove the U-bolts attaching the transaxle to the leaf springs (**Figure 17b-11, Page 17b-7**).
13. Carefully lift each end of the transaxle off its positioning pin (on the leaf spring) and slide the transaxle to the rear and out of the vehicle.
14. Drain the lubricant from the transaxle and remove the axle shafts. **See Axle Shaft and Oil Seal Removal on page 17b-1. See following NOTE.**

**NOTE:** *Recycle or dispose of used oil or lubricant in accordance with local, state, and federal regulations.*

15. Remove the brake assemblies if required. **See Section 6 – Wheel Brake Assemblies in the appropriate maintenance and service manual.**

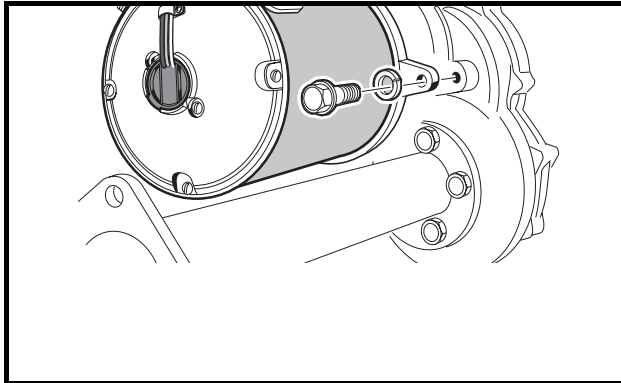
**Transaxle Removal, Continued:**

Figure 17b-13 Motor Positioning Bolt

## TRANSAXLE DISASSEMBLY, INSPECTION, AND ASSEMBLY

---

See General Warning, Section 10, Page 10-1.

### TRANSAXLE DISASSEMBLY AND INSPECTION

1. To detach axle tubes (16 and 40) from the transaxle housing, remove the bolts and lock washers (8 and 9) (Figure 17b-4, Page 17b-3).

**NOTE:** Shims are located between axle tube and differential case bearing. Do not damage shims. If shims are removed, set them aside for reinstallation.

2. Remove 10 bolts (26) that hold housing together.
3. Pull the halves of the housing (11 and 24) apart. If necessary, tap lightly on the spline of the input pinion (19). See following **CAUTION**.

#### **CAUTION**

- To prevent damage to the housing mating seal surfaces, use caution when separating halves.
4. Remove input pinion gear (19) by pulling gear out while rocking intermediate gear assembly (23). Lift intermediate gear assembly and differential gear case unit out simultaneously (Figure 17b-4, Page 17b-3). See following **CAUTION**.

#### **CAUTION**

- Do not damage gears. Use extreme care when handling them.
5. Use a bearing puller or arbor press to remove bearings (18) from the input pinion gear. If the oil seal (10) is damaged, replace it (Figure 17b-4, Page 17b-3). See also Figure 17b-14, Page 17b-9. See following **CAUTION**.

## **⚠ CAUTION**

- Do not reuse bearings after removing them. Replace bearings with new ones.

6. To disassemble the intermediate gear assembly, press off together the bearing (18) and the gear (23) (Figure 17b-4, Page 17b-3). See also Figure 17b-14, Page 17b-9.
7. Remove key (22) (Figure 17b-4, Page 17b-3). See also Figure 17b-15, Page 17b-9.

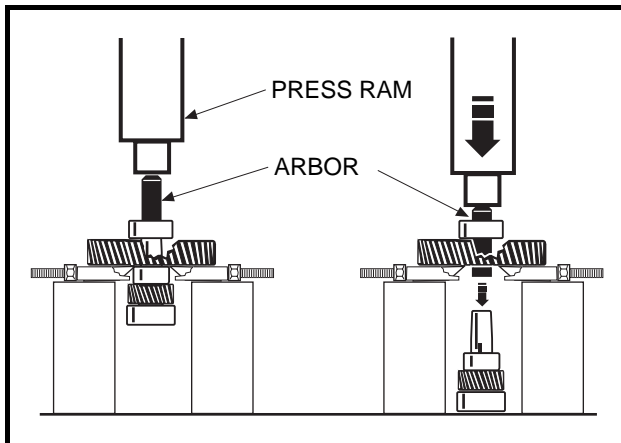


Figure 17b-14 Intermediate Gear Assembly

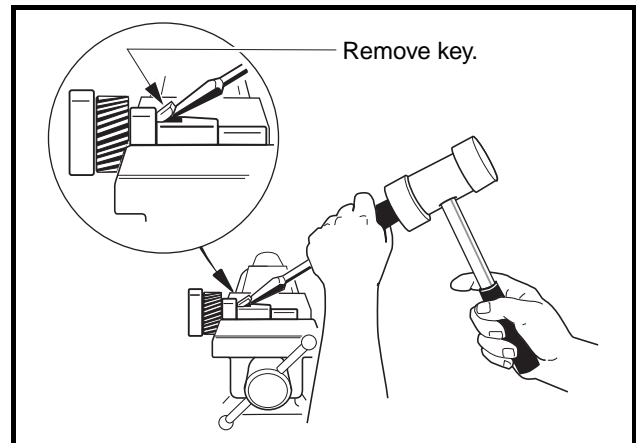
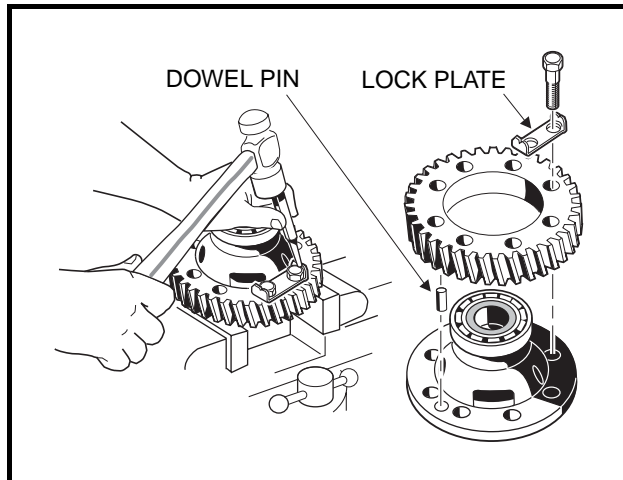


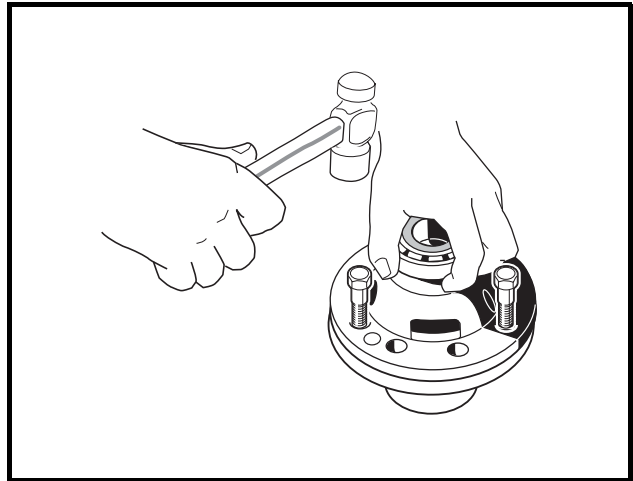
Figure 17b-15 Remove Key

8. Press the bearing (20) off the intermediate gear assembly (Figure 17b-4, Page 17b-3).
9. Disassemble the differential gear case:
  - 9.1. Bend the bolt lock plates (29) down onto the ring gear (30) (Figure 17b-4, Page 17b-3). See also Figure 17b-16, Page 17b-10.
  - 9.2. Remove eight hex bolts (28) that secure the ring gear to the differential case (Figure 17b-4, Page 17b-3).
  - 9.3. Remove the ring gear. Retain dowel pin (41) from between the ring gear and differential case for reassembly.
  - 9.4. Separate the differential gear case housing. If necessary, reinstall two of the hex bolts (removed previously in step 9.2.) into the differential gear unit and, while holding the unit slightly above the

work area, lightly tap the bolt heads (**Figure 17b-17, Page 17b-10**). Remove the two bolts.



**Figure 17b-16** Lock Plate



**Figure 17b-17** Separate Housing



**Transaxle Disassembly and Inspection, Continued:**

- 9.5. Remove the differential pin (31) by pushing pin through differential gear case from one side (**Figure 17b-4, Page 17b-3**). **See also Figure 17b-18, Page 17b-11.**
- 9.6. Remove the idler gears and thrust plates (1 and 2) (**Figure 17b-19, Page 17b-11**).
- 9.7. Remove the differential gears and thrust plates (3 and 4).
- 9.8. Inspect the bearings (14) of the differential case and replace them if they are damaged (**Figure 17b-4, Page 17b-3**). To remove them, press them off. **See following CAUTION.**

**▲ CAUTION**

- Do not reuse bearings after removing them. Replace bearings with new ones.

10. Inspect parts for wear or damage. Any worn or damaged parts should be replaced. **See following NOTE.**

**NOTE:** Damaged or worn gears should be replaced as sets.

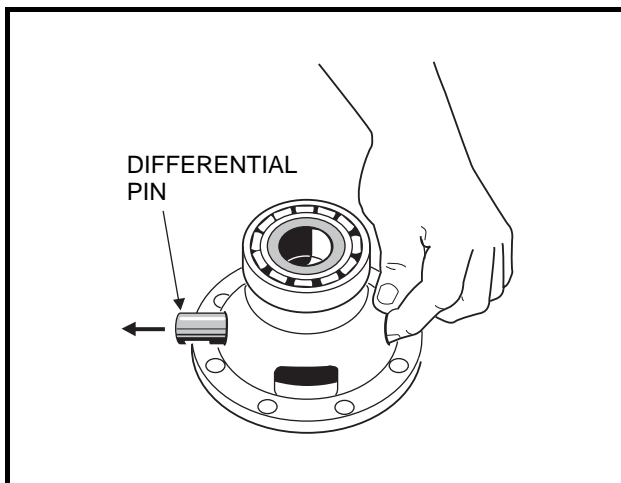


Figure 17b-18 Differential Pin

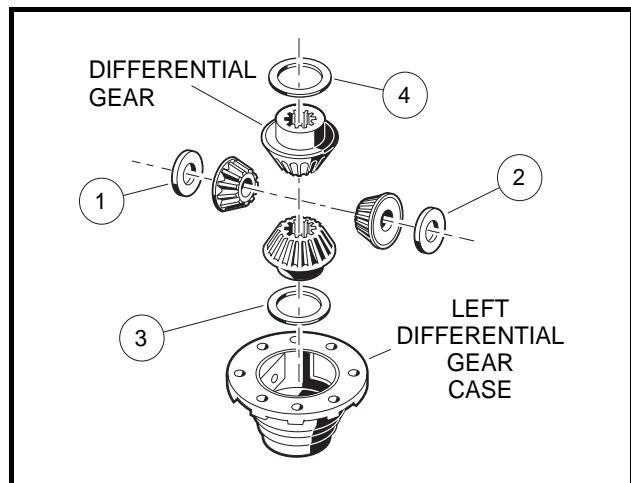


Figure 17b-19 Left Differential

**TRANSAXLE ASSEMBLY****▲ CAUTION**

- Do not press against the bearing outer race.
- Gasket (13) faces of the housing must be clean and smooth. use only a new gasket that is not torn or damaged. The gasket must lie flat against the housing faces (**Figure 17b-4, Page 17b-3**).
- The housing and all parts must be wiped clean and dry before reassembly.

1. If bearings (14) were removed during disassembly, install new bearings using an arbor press (**Figure 17b-4, Page 17b-3**).
2. Assemble the differential gear case.
  - 2.1. Install the pin (31) (**Figure 17b-4, Page 17b-3**). Apply a small amount of oil to all thrust plates and to both ends of the pin.
  - 2.2. While aligning the dowel pin, assemble the two halves of the differential gear case (33 and 36) and reinstall the output gear (30) (**Figure 17b-4, Page 17b-3**).

- 2.3. Install eight hex bolts (28) and the bolt lock plates (29). Tighten the bolts to 18 ft-lb (24 N·m).
  - 2.4. Bend the edges of the bolt locking tabs securely against the flats of the bolt heads to prevent the bolts from loosening and possibly causing damage (**Figure 17b-16, Page 17b-10**).
  - 2.5. If the large gear (23) was removed from the intermediate gear, insert key (22) into keyway in the shaft and then press the large gear and the bearing (18) onto the shaft. Be sure the key is properly positioned in the keyway before attempting to press on the large gear and bearing (**Figure 17b-4, Page 17b-3**).
  3. Press a new bearing (20) onto the intermediate gear assembly (**Figure 17b-4, Page 17b-3**).
  4. Press new bearing (18) onto input pinion gear (19).
  5. Apply grease to the lip of the new oil seal (10) and install the seal using a transaxle pinion seal tool (CCI P/N 1014161). The lip of the oil seal should face the inside of the transaxle housing. Make sure the seal is firmly seated.
  6. Install the differential assembly, the intermediate gear assembly, and the input pinion gear simultaneously. Be sure all bearings are seated properly in the housing. Rotate the input shaft to check for smooth gear operation (**Figure 17b-12, Page 17b-7**).
  7. Install both dowel pins (27) in the transaxle housing (24) (**Figure 17b-4, Page 17b-3**).
  8. Install left half of transaxle housing:
    - 8.1. Place a 1/8 inch (3 mm) bead of Three Bond liquid gasket on mating surface of housing.
    - 8.2. Install left half of transaxle housing (24) (**Figure 17b-4, Page 17b-3**).
    - 8.3. Install the ten bolts (26) and tighten to 69 in-lb (7.8 N·m).
    - 8.4. If the axle tube (16 and 40) was removed, install the shims (39), (if the shims were removed) and Three Bond liquid gasket. Install the axle tube with five lock washers and bolts (9 and 8). Tighten the bolts to 36 ft-lb (49 N·m).
- NOTE:** If the differential case (33 and 36), the transaxle housing (11 and 24) or axle tube (16 and 40) (**Figure 17b-4, Page 17b-3**) was replaced, shim the transaxle. See **Shimming the Transaxle on page 17b-13**.
9. Install the brake assemblies as instructed. See **Section 6 – Wheel Brake Assemblies of the appropriate maintenance and service manual**.
  10. Apply a small amount of grease to the lip of the oil seal (17) (**Figure 17b-4, Page 17b-3**).

### **⚠ CAUTION**

- Clean any residual oil from the exposed end of the axle shaft and from the oil seal area prior to installing the axle shaft.
11. Clean the splines on the axle shaft (1 and 2). Rotate the axle to align the shaft splines with the splined bore of the differential side gear. Push the shaft in until the bearing seats against the shoulder in the axle tube.
  12. Install the retaining ring (6) in the axle tube. See following **WARNING**.

### **⚠ WARNING**

- Be sure the retaining ring is properly seated in its groove. If the ring is not properly installed, the axle assembly will separate from the transaxle and damage the axle assembly and other components. Loss of vehicle control could result, causing severe personal injury.

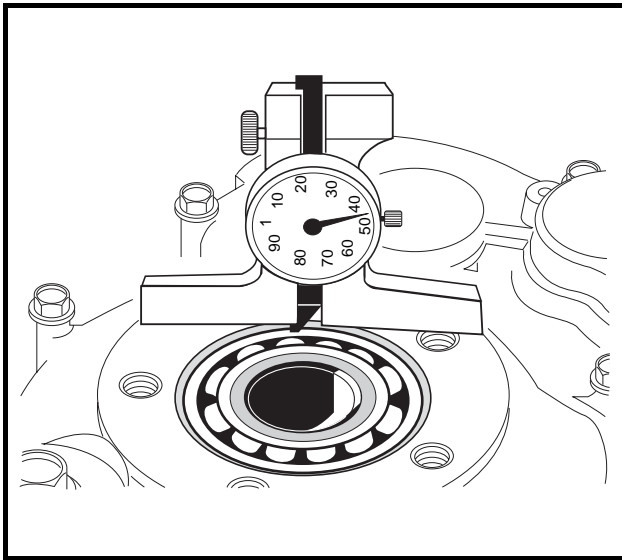
**Transaxle Assembly, Continued:**

13. Make sure the drain plug (44) is installed in the transaxle and tightened to 23 ft-lb (31 N·m). Fill the transaxle, through the level indicator hole, with 22 ounces of SAE 30 API Class SE, SF, or SG oil (a higher grade may also be used). Install and tighten the level indicator plug (25) to 23 ft-lb (31 N·m).

**SHIMMING THE TRANSAXLE**

If the differential case (36 and 33), transaxle housing (11 and 24), or axle tube (16 and 40) has been replaced, the transaxle may need new shims. To determine whether new shims are necessary, the transaxle must be completely assembled except for the short axle tube (16) and both axle shafts (1 and 2) (**Figure 17b-4, Page 17b-3**).

1. Stand the transaxle on end, on the axle tube.
2. Using a depth gauge, measure the distance from the gasket seal surface of the axle tube to the outer race of the bearing (14) on the differential case assembly (32) (**Figure 17b-4, Page 17b-3**). See also **Figure 17b-20, Page 17b-13**.



**Figure 17b-20** Depth Gauge

3. Use the following charts to determine whether shimming is required and, if so, how many shims (CCI P/N 1013781) should be used.

SEAL SURFACE MEASUREMENT	SHIMS REQUIRED
Up to .134 in. (3.4 mm)	0
.134 -.142 in. (3.4-3.6 mm)	1
.142 -.150 in. (3.6-3.8 mm)	2
.150 -.155 in. (3.8-3.9 mm)	3

## TRANSAXLE INSTALLATION

---

### See General Warning, Section 10, Page 10-1.

1. If using a chain hoist, raise the vehicle and place transaxle in position on the jack stands. If using a floor jack, lower the jack stands to their lowest settings and place the transaxle in position on the jack stands.
2. Align the center hole in the saddle of the transaxle with the pilot bolt in the leaf spring assembly.
3. Install the two U-bolts, jounce bumper mount and spacers, lock washers, and nuts. Tighten the nuts to 25 ft-lb (34 N·m). Tighten the U-bolt nuts so an equal amount of thread is visible on each leg of the bolt.
4. Install the motor. **See Section 16 – Motor.**
5. If using a chain hoist, lower the vehicle while guiding the leaf springs into the rear spring shackles. If using a floor jack, raise the differential while guiding the leaf springs into the rear spring shackles. Then raise the jack stands to support the transaxle.
6. Connect the four motor wires. Tighten the retaining nuts to 65 in-lb (7.3 N·m). Use two wrenches to prevent the posts from turning. **See following NOTE.**

**NOTE:** *If the motor wires were not tagged when disconnected, refer to the wiring diagram for proper connection. See Wiring Diagram, Section 11, Page 11-10.*

7. Insert bolts through the spring shackles and bushings in the leaf spring eyes. Secure bolts with lock nuts. Tighten to 15 ft-lb (20.3 N·m).
8. Connect the brake cables.
9. Install the shock absorbers. Tighten shock absorber retaining nuts until the rubber bushings expand to the same size as the cup washers.
10. Install the rear wheels and finger tighten the lug nuts.
11. Lift the vehicle and remove the jack stands.
12. Lower vehicle and tighten the lug nuts, using a crisscross pattern, to 55 ft-lb (74.6 N·m).
13. Test drive the vehicle to check for proper operation.

# SECTION 18 – IQ DISPLAY MODULE (IQDM-P) PROGRAMMING

---

## **⚠ DANGER**

- See General Warning, Section 10, Page 10-1.

## **⚠ WARNING**

- See General Warning, Section 10, Page 10-1.

## PLUGGING THE HANDSET INTO THE VEHICLE

---

1. Connect one end of the cable to the jack located on the bottom of the handset.
2. Connect the cable adaptor to the IQDP-P cable.
3. Find the IQDM jack on the vehicle.
4. Remove the dust cap from the IQDM jack.
5. Align the keyed portion of the plug with the IQDM jack and connect the plug to the jack.

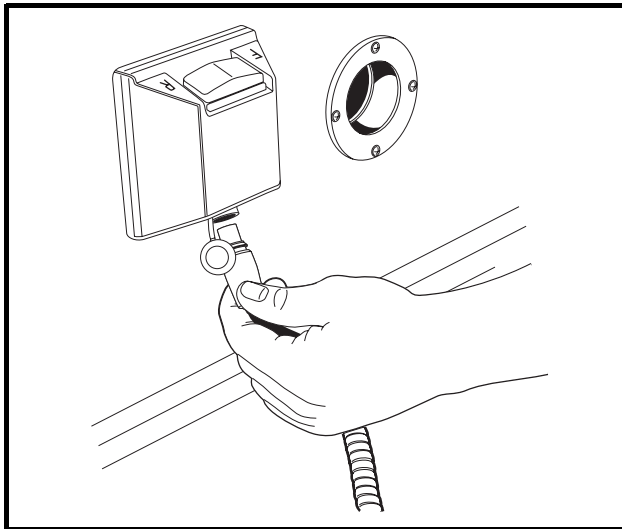


Figure 18-1 Connector Under Forward/Reverse Switch

## PROGRAM MENU

The *program* menu can be accessed by pressing the right arrow on the navigation button when the square beside *program* is blinking (**Figure 18-2**). When the *program* menu is active, use the up or down arrows on the navigation button to go to the desired item in the *program* menu. Again, press the right arrow to select the menu item. Use the change value button to change the values of the selected item as necessary.

The following parameters can be programmed with the handset from the *program* menu:

## SPEED SETTING

The vehicle's top speed can be changed by selecting values 1 through 3 (**Figure 18-3**). If a value of 4 is displayed for the speed setting, a special access code has been entered to place the vehicle in "private speed mode." A speed setting of 4 cannot be selected with the *speed setting* menu item. For additional information on speed setting 4, refer to Code A, Code B, and Code C. **See Code A, Code B, and Code C on page 18-3.**

SPEED SETTING	DESCRIPTION	VEHICLE SPEED
1	Commercial speed	8.0 mph (12.9 km/h)
2	Slow golf speed	13.4 mph (21.6 km/h)
3	Normal golf speed	14.8 mph (23.8 km/h)
4	Private speed mode	19.6 mph (31.5 km/h)

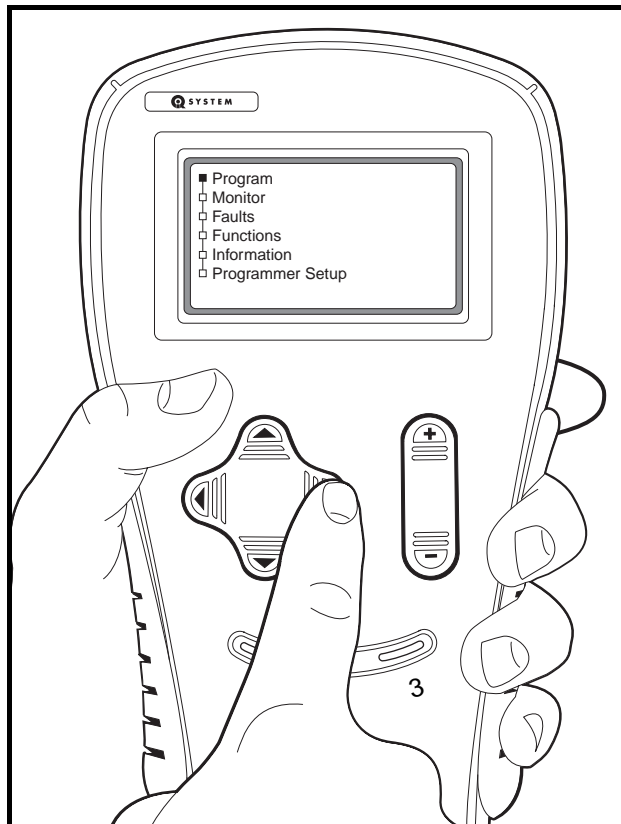


Figure 18-2 Access Program Menu

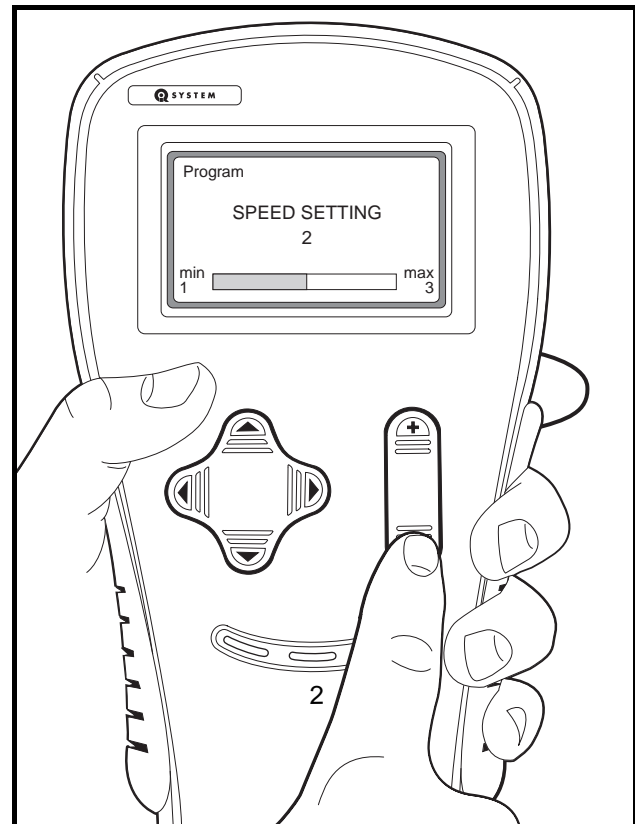


Figure 18-3 Change Speed Setting

## FAST ACCEL

*Fast accel* (fast acceleration) is an option that can be enabled or disabled. With *fast accel* turned on, the vehicle will accelerate at a noticeably faster rate. With this feature turned off, the vehicle speed will gradually increase, even if the accelerator is quickly pressed to the floor. Turn the feature on or off by pressing + or – on the change value button.

## PEDAL UP MODE

Three options exist for *pedal up mode* (motor braking). When the accelerator pedal is released, motor braking will slow the vehicle to a speed of approximately 11 mph (17.7 km/h) when pedal up motor braking is enabled (option 1 or 2). If pedal up motor braking is disabled (option 0), the vehicle will coast to a stop when the pedal is released. **See following NOTE.**

Change the settings of the Pedal Up Mode by pressing + or – on the change value button.

**NOTE:** *Pedal up mode does not affect top vehicle speed. If the accelerator pedal is released when the vehicle is going down an incline, the motor braking function will activate, slowing the vehicle to the speed setting defined in the Program menu. See Speed Setting on page 18-2.*

PEDAL UP MODE SETTING	MODE	OPERATION DESCRIPTION
0	Off	Pedal up motor braking is disabled
1	Mild pedal up	Mild pedal up motor braking
2	Aggressive pedal up	Aggressive pedal up motor braking

## SPEED CAL

The *speed cal* (speed calibration) menu item allows the user to fine tune the vehicle speed. This feature cannot be used to increase the vehicle speed. The range for speed calibration is 0 to 10. Each time the number is increased, the top speed will be decreased by 0.12 mph (0.2 km/h). The top vehicle speed will be determined by the *speed setting* menu item and the speed calibration setting. For example, if the speed setting is set for a value of 3 (14.8 mph (23.8 km/h)), and the speed calibration is set for 5, the total top speed of the vehicle should be approximately 14.2 mph (22.9 km/h).

## CODE A, CODE B, AND CODE C

The code entries are used to place the vehicle in “private speed mode”, speed setting code 4. Each vehicle has a unique code for placing the vehicle in this mode. A vehicle programmed for “private speed mode”, speed setting 4, does not conform to ANSI Z130.1 – American National Standard for Golf Cars – Safety and Performance Specifications because it is capable of speeds in excess of 15 mph (24.1 km/h). For more information on this feature, contact your local Club Car distributor or dealer.





**A****armature, motor**

see motor, armature

**B****batteries** ..... 14-1

see also battery charger

care ..... 14-4

charge circuit ..... 11-9

charging ..... 14-6

deep discharge ..... 14-7

electrolyte

adding water (mineral content) ..... 14-6

level ..... 14-5

excessive early discharging ..... 14-7

fleet rotation ..... 14-7

hydrometer calibration ..... 14-10

maintenance, preventive ..... 14-4

see also batteries, electrolyte

misconceptions about batteries ..... 14-3

replacement ..... 14-3

self-discharge ..... 14-5

storage ..... 14-14

testing ..... 14-9

discharge test ..... 14-11

interpreting test results ..... 14-12

hydrometer test ..... 14-9

interpreting results ..... 14-10

on-charge voltage test ..... 14-9

voltage test ..... 11-16

voltage test (under load) ..... 11-22

troubleshooting examples ..... 14-13

vibration damage ..... 14-6

**battery charger**

16 hour shut-off ..... 14-7

AC service, incoming ..... 14-7

charge circuit ..... 11-9

numbering vehicles and chargers ..... 14-7

testing ..... 14-9

on-charge voltage test ..... 14-9

**battery warning light** ..... 11-4

installation ..... 13-13

removal ..... 13-13

testing ..... 11-40

**bearing, axle**

see transaxle, type g, axle bearing

see transaxle, type k, axle bearing

**bearing, motor**

see motor, bearing

**braking, motor**

see regenerative braking

**braking, regenerative**

see regenerative braking

**C****charger receptacle**

fuse link ..... 13-13

installation ..... 13-13

removal ..... 13-13

installation ..... 13-12

removal ..... 13-12

testing ..... 11-35

**circuits**

electrical ..... 11-2

see also electrical system, circuits

**communication display module (CDM)**

function codes ..... 11-41

retrieving data from ..... 11-42

troubleshooting ..... 11-43

**connector, 16-pin**

see test procedures

**D****differential**

see transaxle, type g

see transaxle, type k

**diode, solenoid**

testing ..... 11-18

**drive motor**

see motor

**drive unit**

see transaxle, type g

see transaxle, type k

**E****electric motor**

see motor

**electrical system** ..... 11-1

charge circuit ..... 11-9

circuits ..... 11-2

control circuit ..... 11-2

onboard computer circuit ..... 11-2

power circuit ..... 11-8

speed control circuit ..... 11-4

testing circuits ..... 11-16

Tow/Run switch circuit ..... 11-6

**F****Forward/Reverse switch**

installation ..... 13-3

removal ..... 13-3

testing ..... 11-38

**fuse, sense lead** ..... 11-35

**H**

**high pedal detect** ..... 11-2

**I**

**inspection**

motor

armature ground test ..... 16-6

armature inspection ..... 16-5

bearing ..... 16-7

field windings ..... 16-6

motor components ..... 16-7

speed sensor magnet ..... 16-9

pre-operation and daily safety checklist ..... 10-3

transaxle, type g ..... 17a-7

transaxle, type k ..... 17b-8

**K**

**key switch**

installation ..... 13-2

removal ..... 13-1

testing ..... 11-23

**L**

**lubrication**

periodic lubrication schedule ..... 10-6

transaxle, type g ..... 17a-1

transaxle, type k ..... 17b-1

**M**

**magnet, motor speed sensor**

see motor, speed sensor magnet

**maintenance**

batteries ..... 14-4

periodic lubrication schedule ..... 10-6

periodic service schedule ..... 10-4

**motor** ..... 11-1, 12-1, 16-1, 18-1

armature

ground test ..... 16-6

inspection ..... 16-5

assembly ..... 16-10

bearing

inspection ..... 16-7

installation ..... 16-9

removal ..... 16-9

braking

pedal down motor braking ..... 11-1

pedal up motor braking ..... 11-1

component

inspection ..... 16-7

disassembly ..... 16-4

features ..... 11-1

field winding inspection ..... 16-6

installation ..... 16-12

motor braking ..... 11-1

protection circuit ..... 11-2

reconditioning ..... 16-9

removal ..... 16-3

service specifications ..... 16-10

speed sensor ..... 16-15

installation ..... 16-15

removal ..... 16-15

testing ..... 11-36

speed sensor magnet

inspection ..... 16-9

installation ..... 16-9

removal ..... 16-9

testing ..... 11-21

see test procedures, motor

zero speed detect ..... 11-1

**motor braking**

see regenerative braking

**motor controller output regulator (MCOR)**

installation ..... 13-6

removal ..... 13-5

testing ..... 11-20, 11-23

**O**

**onboard computer** ..... 11-2

**onboard computer (OBC)**

installation ..... 13-8

onboard computer circuit ..... 11-2

rebooting ..... 11-40

removal ..... 13-8

retrieving data from ..... 11-42

testing ..... 11-17, 11-35

**P**

**periodic lubrication schedule** ..... 10-6

**periodic service schedule** ..... 10-4

**R**

**receptacle**

see charger receptacle

**regenerative braking** ..... 11-1

**reverse buzzer**

installation ..... 13-6

removal ..... 13-6

testing ..... 11-39

**S****safety**

pre-operation and daily safety checklist .....10-3

**service schedule**

see periodic service schedule

see also periodic lubrication schedule

**solenoid**

installation .....13-7

removal .....13-7

testing .....11-37

**solenoid activating coil**

testing .....11-18

**speed controller**

cloning .....12-11

connector, 16-pin  
see test procedures

installation .....13-11

removal .....13-10

**speed sensor**

see motor, speed sensor

**T****test procedures**

1 – batteries/voltage check .....11-16

2 – onboard computer solenoid lockout circuit .....11-17

3 – solenoid activating coil .....11-18

3 – solenoid diode .....11-18

4 – MCOR .....11-20

5 – motor, A1 and A2 voltage .....11-21

6 – Tow/Run switch .....11-22

7 – battery pack voltage (under load) .....11-22

8 – key switch .....11-23

8 – MCOR limit switch .....11-23

9 – 16-pin connector .....11-25

10 – onboard computer SCR .....11-35

11 – OBC gray wire and fuse .....11-35

12 – charger receptacle .....11-35

13 – speed sensor, motor .....11-36

14 – solenoid .....11-37

15 – Forward/Reverse rocker switch .....11-38

16 – reverse buzzer .....11-39

17 – OBC, rebooting .....11-40

18 – battery warning light .....11-40

**test procedures, IQDM**

1 – handset cord .....12-16

2 – handset cord adaptor .....12-17

3 – IQDM jacks .....12-17

**test procedures, motor**

1 – internal short circuits .....16-1

2 – armature circuit open .....16-2

3 – field circuit open .....16-2

armature ground test .....16-6

**Tow/Run switch** .....11-2

installation .....13-4

removal .....13-4

testing .....11-22

**transaxle, type g**

assembly .....17a-9

axle bearing .....17a-4

axle shaft

installation .....17a-4

removal .....17a-1

disassembly .....17a-7

identification .....17a-1

inspection .....17a-7

installation .....17a-10

lubrication .....17a-1

oil seal

installation .....17a-4

removal .....17a-1

removal .....17a-5

**transaxle, type k**

assembly .....17b-11

axle bearing .....17b-4

installation .....17b-4

removal .....17b-4

axle shaft

installation .....17b-5

removal .....17b-1

disassembly .....17b-8

identification .....17b-1

inspection .....17b-8

installation .....17b-14

lubrication .....17b-1

oil seal

installation .....17b-5

removal .....17b-1

removal .....17b-5

shimming .....17b-13

**troubleshooting** .....11-10

battery troubleshooting examples .....14-13

communication display module (CDM) .....11-43

IQDM and IQDM-P handset .....12-15

troubleshooting guide 1 .....11-11

troubleshooting guide 2 .....11-14

**W****warning light, battery**

see battery warning light

**water level**

see batteries, electrolyte level

**Z**

**zero speed detect** ..... 11-1

## Your Comments Are Appreciated

Please select your category:

- Distributor/Dealer
- Individual Owner
- Other: \_\_\_\_\_
- Technician
- Golf Course Superintendent

In order to help us better serve you, please rate this publication in the following categories:

	Poor	Fair	Average	Good	Excellent
1. Ease of Understanding	<input type="checkbox"/>	<input type="checkbox"/>	<input type="checkbox"/>	<input type="checkbox"/>	<input type="checkbox"/>
2. Ease of Finding Information	<input type="checkbox"/>	<input type="checkbox"/>	<input type="checkbox"/>	<input type="checkbox"/>	<input type="checkbox"/>
3. Clarity of Illustrations	<input type="checkbox"/>	<input type="checkbox"/>	<input type="checkbox"/>	<input type="checkbox"/>	<input type="checkbox"/>
4. Index Usability	<input type="checkbox"/>	<input type="checkbox"/>	<input type="checkbox"/>	<input type="checkbox"/>	<input type="checkbox"/>
5. Troubleshooting Chart Usability	<input type="checkbox"/>	<input type="checkbox"/>	<input type="checkbox"/>	<input type="checkbox"/>	<input type="checkbox"/>

Comments/Suggestions:

---

---

---

---

---

---

---

---

---

---

---

---

---

---

---

---

---

---

---

---

---

---

---

---

Please fax a copy of this page to (706) 228-2662.

Thank You!  
Club Car Technical Publications Department







**Golf Cars**

---

Club Car Inc.

P.O. Box 204658

Augusta, GA 30917-4658